

DISTRIBUTION STATEMENT — Distribution authorized to U.S. Government agencies only for administrative or operational use (effective date is date of this manual). Other requests for this document must be referred to San Antonio ALC/MMEDT, Kelly AFB, TX 78241-5000.

THIS MATERIAL MAY BE REPRODUCED BY OR FOR THE U.S. GOVERNMENT PURSUANT TO THE COPYRIGHT LICENSE UNDER THE (DFAR) CLAUSE AT 52.227-7013 (15 MAY 1987).

HANDLING AND DESTRUCTION NOTICE — Comply with distribution statement and destroy by any method that will prevent disclosure of contents or reconstruction of the document.

9100 Series

Service Manual

P/N 809210

May, 1988

©1988, John Fluke Mfg. Co., Inc. All rights reserved. Litho in U.S.A.



LIMITED WARRANTY

John Fluke Mfg. Co., Inc. (Fluke) warrants your 9100/9105A to be free from defects in material and workmanship under normal use and service for 90 days from the date of shipment. Software and firmware products are provided "AS IS." We do not warrant that software or firmware products will be error free, operated without interruption or that all errors will be corrected. This warranty extends to you if you are the original purchaser and does not apply to fuses, batteries or any product which, in our sole opinion, has been subject to misuse, alteration or abnormal conditions of operation or handling.

To obtain warranty service, contact a Fluke Service Center or send the product, with the description of the difficulty, postage prepaid, to the nearest Fluke Service Center. Fluke assumes no risk for damage in transit.

Fluke will, at our option, repair or replace the defective product free of charge. However, if we determine that the failure was caused by misuse, alteration, or abnormal condition of operation or handling, you will be billed for the repair. The repaired product will be returned to you, transportation prepaid.

THIS WARRANTY IS EXCLUSIVE AND IS IN LIEU OF ALL OTHER WARRANTIES, EXPRESS OR IMPLIED, INCLUDING BUT NOT LIMITED TO ANY IMPLIED WARRANTY OF MERCHANTABILITY OR FITNESS FOR A PARTICULAR PURPOSE OR USE. FLUKE WILL NOT BE LIABLE FOR ANY SPECIAL, INDIRECT, INCIDENTAL, OR CONSEQUENTIAL DAMAGES OR LOSS WHETHER IN CONTRACT, TORT, OR OTHERWISE.

SUPPLEMENTAL PARTS LIST

The information in this supplement replaces the parts lists found in the following manual:

MANUAL

Title: 9100 Series Service
Part Number: 809210
Print Date: May 1988
Rev. and Date: ---

1944-1945

Year	1944	1945
1		
2		
3		
4		
5		
6		
7		
8		
9		
10		
11		
12		
13		
14		
15		
16		
17		
18		
19		
20		
21		
22		
23		
24		
25		
26		
27		
28		
29		
30		
31		
32		
33		
34		
35		
36		
37		
38		
39		
40		
41		
42		
43		
44		
45		
46		
47		
48		
49		
50		
51		
52		
53		
54		
55		
56		
57		
58		
59		
60		
61		
62		
63		
64		
65		
66		
67		
68		
69		
70		
71		
72		
73		
74		
75		
76		
77		
78		
79		
80		
81		
82		
83		
84		
85		
86		
87		
88		
89		
90		
91		
92		
93		
94		
95		
96		
97		
98		
99		
100		

Table 5-1. Model Configurations

		9100A/SYS Digital Test Programming Station							
		9100A Digital Test System							
		9100A-003 Parallel I/O Module							
		9100A-004 Programmer's Station, Mono							
		9100A-005 Programmer's Station, Color (Table 5-21)							
		9100A-009 Video, Monochrome (Table 5-23)							
		9100A-011 Video, Color (Table 5-24)							
		9105A Digital Test Station							
RELATED PARTS LISTS:									
Table	Assembly/Option	↓	↓	↓	↓	↓	↓	↓	↓
5-2	Final Assembly	X						X	X
5-3	A1 Main PCA	X						X	X
5-4	A2 Display Interface PCA	X						X	X
5-5	A4 Video Controller PCA		X	X	X	X			X
5-6	A5 Probe PCA	X						X	X
5-7	A6 Clock Module PCA	X						X	X
5-8	A7 I/O Module (Main) PCA						X		X
5-9	A8 I/O Module (Top) PCA						X		X
5-10	A9 Probe I/O PCA	X						X	X
5-11	A10 Multi-Function I/F PCA							X	X
5-12	A11 I/O Connector PCA	X						X	X
5-13	A12 Half-Width Clip Module								X
5-14	A13 Full-Width Clip Module								X
5-15	A14 Calibration Module						X		X
5-16	A15 Flying Lead Module						X		X
5-17	A16 512K RAM Module*	X						X	X
5-18	A19 Monochrome Monitor			X		X			X
5-19	-003 Parallel I/O Module								X
5-20	-004 Programmer's Station, Mono								X
5-22	-008 Real-Time Clock PCA (optional)	X							
5-25	-013 Programmer's Keyboard				X	X			X

* -007 512K Memory Expansion is included in Table 5-17.

5/List of Replaceable Parts

Table 5-2. 9100 Series Final Assembly
(See Figure 5-1.)

REFERENCE DESIGNATOR	FLUKE STOCK	MFRS SPLY	MANUFACTURERS PART NUMBER	TOT QTY	R O S T	N
AS NUMERICS	NO	CODE	OR GENERIC TYPE		-Q	-E
A 1	* MAIN PCA	768754	89536 768754	1		
A 2	* DISPLAY INTERFACE PCA	768689	89536 768689	1		
A 3	KEYPAD ASSEMBLY	846357	89536 846357	1		
A 5	* PROBE ASSEMBLY	773911	89536 773911	1		
A 6	* CLOCK MODULE ASSEMBLY	768812	89536 768812	1		
A 9	* PROBE I/O INTERFACE PCA	768796	89536 768796	1		
A 10	* MULTI-FUNCTION INTERFACE PCA	767988	89536 767988	1		1
A 11	* I/O CONNECTOR PCA	767996	89536 767996	1		
A 16	* 512K RAM MODULE	822858	89536 822858	4		3
A 101	PWR SUP, 150W, +5V, (2)+12V, -5V	772988	61852 XLI60-3416	1		
A 102	* DISK DRIVE, FLOPPY, 3.5"	829671	89536 829671	1		2
A 104	* DISK DRIVE, HARD, 3.5", FRMTD, 20MBYTS	834234	89536 834234	1		1
A 105	* WINCHESTER HARD DISK CONTROLLER	780940	52840 WD1002S-SHD	1		1
CH 1	* LED, RED, PCB MNT, LUM INT=0.5MCD	369777	28480 5082-4480	1		1
E 1	TERM, FASTON, REC, 18-22AWG, CRIMP, INSUL	655001	59730 RAD20377	1		
F 1	FUSE, 1/4 X 1-1/4, SLOW, 2A, 250V	109181	71400 MDX2	1		5
F 1	FUSE, 5X20MM, SLOW, 1A, 250V	808055	61935 034.3117	1		5
H 1	SPACER, HEX, ALUM, 4-40X0.500	192872	COMMERCIAL	1		
H 2	SCREW, MACH, PHP SEMS, STL, 4-40X1/4	185918	COMMERCIAL	2		
H 3	SCREW, MACH, PHP, STL, 4-40X1/2	558825	COMMERCIAL	4		
H 4	SCREW, MACH, PH, P, STL, 6-32X0.250	152140	COMMERCIAL	1		
H 5	NUT, WELD TAB, FLOATING, STEEL, 10-32	743393	COMMERCIAL	2		
H 6	SCREW, MACH, PH, P, STL, 6-32X0.250	152140	COMMERCIAL	5		
H 7	SCREW, MACH, PH, P, STL, 10-32X0.750	114306	COMMERCIAL	2		
H 8	SCREW, MACH, PH, P, STL, 6-32X0.250	152140	COMMERCIAL	14		
H 9	SCREW, MACH, PH, P, STL, 8-32X0.375	114124	COMMERCIAL	2		
H 10	CONN ACC, D-SUB, LATCH BLOCK, SHORT, SLOT	811653	00779 745245-3	12		
H 11	SCREW, MACH, FIHS, STL, 4-40X3/8	129916	COMMERCIAL	12		
H 12	CONN ACC, D-SUB, SLIDING LOCK, POST ASSY	353201	54492 D53018	2		
H 13	CONN ACC, D-SUB, JACK SCREW, 4-40	448092	89536 448092	4		
H 14	SCREW, MACH, PH, P, STL, 6-32X0.250	152140	COMMERCIAL	4		
H 15	RIVET, PUSH, UNIV, NYL, .16, .32	799957	06915 SR-4080	4		
H 16	SCREW, MACH, PH, P, STL, 6-32X0.375	152165	COMMERCIAL	2		
H 17	NUT, CAP EXT LW, STL, 6-32X7/64	152819	COMMERCIAL	2		
H 18	DUST FILTER, SET	773994	89536 773994	1		
H 19	WASHER, SHLDR, NYLON, .320X.141X.065	733345	7W423 2703-1865-N141	4		
H 20	RIVET, POP, DOME, AL, 0.125X0.440	800763	COMMERCIAL	4		
H 21	FASTENER, STUD REC, TUBLR, 0.187 X 0.46	783134	78553 C2694-156-4	2		
H 22	SCREW, MACH, PH, P, STL, 6-32X0.250	152140	COMMERCIAL	8		
H 23	SCREW, MACH, PH, P, STL, 8-32X0.375	114124	COMMERCIAL	4		
H 24	SCREW, MACH, SEMS, PH, P, STL, 6-32X0.375	177022	COMMERCIAL	4		
H 25	SCREW, MACH, PHS, M3 X 12	799502	COMMERCIAL	4		
H 26	SCREW, MACH, PH, P, STL, 6-32X0.500	152173	COMMERCIAL	4		
H 27	SCREW, MACH, PH, P, STL, 6-32X0.250	152140	COMMERCIAL	2		
H 28	SCREW, MACH, PH, P, STL, 6-32X0.250	152140	COMMERCIAL	3		
H 29	SCREW, SHOULDER	775999	89536 775999	2		
H 30	CONN ACC, D-SUB, DUST CAP, 37 SCKT	615138	71468 DC-59-20	4		
H 31	CONN ACC, D-SUB, DUST CAP, 25 PIN	816371	71468 DB-60-20	2		
H 32	SCREW, MACH, PH, P, STL, 4-40X0.250	129890	COMMERCIAL	1		
J 1	CONN, COAX, BNC (F), PANEL	152033	95712 30355-1	1		
MP 1	BOX, MAILER, CONVOLUTED FOAM INSIDE	707851	ODSM7 CPC400	2		
MP 2	DISPLAY WINDOW, SHIELD	784009	89536 784009	1		
MP 3	9100A ACCESSORIES	788554	89536 788554	1		1
MP 5	SHIELD, CLOCK MODULE	755793	89536 755793	1		
MP 6	CASE, CLOCK MODULE	755827	89536 755827	1		
MP 7	COVER	755686	89536 755686	1		
MP 8	CASE, CLOCK MODULE	755652	89536 755652	1		
MP 10	KEYPAD CASE TOP	765008	89536 765008	1		
MP 11	KEYTOP, SET	775858	89536 775858	1		
MP 12	KEYPAD, ELASTOMERIC	764910	89536 764910	1		1
MP 13	CORD, LINE, 5-15/IEC, 3-18AWG, SVT	343723	70903 17237	1		
MP 14	TORSION SPRING	784025	89536 784025	2		1
MP 15	KEYPAD CASE BOTTOM	765016	89536 765016	1		
MP 16	SPRING DETENT	765032	89536 765032	2		
MP 17	NAMEPLATE	787275	89536 787275	1		
MP 18	FRONT PANEL, PAINTED	764894	89536 764894	1		
MP 19	LENS	783993	89536 783993	1		4
MP 20	KEYPAD OPENING SHIELD	767889	89536 767889	1		
MP 21	HINGE/DETENT HOUSING	765024	89536 765024	2		
MP 22	MAINFRAME BASE	767848	89536 767848	1		

An * in 's' column indicates a static-sensitive part.

5/List of Replaceable Parts

Table 5-2. 9100 Series Final Assembly (cont.)

REFERENCE DESIGNATOR	FLUKE STOCK	MFRS SPLY	MANUFACTURERS PART NUMBER	TOT QTY	R S T	N O T
-A>-NUMERIC->	S	DESCRIPTION	-NO-- -CODE- -OR GENERIC TYPE-	QTY	-Q-	-E-
MP 24		DECAL, CHASSIS CONNECTOR	803221 89536 803221	1		
MP 25		FOOT,VINYL,NYL.PUSH RIVET,0.787X0.236	801001 06915 FF-008-P4X7	4		
MP 26		REAR PANEL	767855 89536 767855	1		
MP 27		HLDR PART,FUSE,CAP,1/4X1-1/4	460238 61935 031.1666	1		
MP 29		EXPANSION SLOT COVER	768010 89536 768010	1		
MP 30		VIDEO SLOT COVER	768655 89536 768655	1		
MP 31		HLDR PART,FUSE,CAP,5X20MM	461020 61935 031.1663	1		
MP 32		CABLE TIE,MOUNT,ADHESIVE,0.19" WIDTH	565036 06383 ABM2S-ATO	1		
MP 33		CABLE TIE,4"L,0.100"W,0.75 DIA	172080 06383 SST1MC	1		
MP 34		SLEEV,POLYOL,SHRINK,.750-.375ID,BLACK	226365 92914 ALPHLEX FIT-221	4		
MP 35		MAINFRAME TOP COVER	773986 89536 773986	1		
MP 36		SHIELD, RFI	768028 89536 768028	1		5
MP 37		LOUVER	787846 89536 787846	1		6
MP 38		POWER SUPPLY SHIELD ASSEMBLY, PLATED	830398 89536 830398	1		
MP 39		CABLE TIE,MOUNT,ADHESIVE,0.19" WIDTH	565036 06383 ABM2S-ATO	1		
MP 40		CABLE TIE,3.62"L,0.091"W,5/8 DIA	381533 06383 PLT1M	1		
MP 41		HARD DISK AND FLOPPY HOUSING	802033 89536 802033	1		7
MP 42		MOUNT,VIBRATION,GROMMET	782623 36000 G-1163T	8		
MP 43		SPACER,NYLON,0.195X0.300	782631 36000 T-306	8		
MP 44		SPACER,PWB,NYL,.125	806703 06915 LMSP-201	2		1
MP 45		NAMEPLATE, SERIAL -REAR PANEL-	472795 89536 472795	1		
MP 46		SYSTEM SOFTWARE, SLEEVED	809103 89536 809103	1		
MP 47		MFI SLOT ESD COVER	819680 89536 819680	1		10
MP 48		REC.MEDIA,DISK,3.5",DSDD,BOX.OF 10	757229 89536 757229	1		
MP 49		CARTON, 9100A	809038 89536 809038	1		
MP 50		END CAP SET, 9100A	809046 89536 809046	1		
MP 51		TRAY/DIVIDERS, 9100A	809053 89536 809053	1		
MP 52		CARTON, PADDED DISK	809129 89536 809129	1		
SW 1		SWITCH,ROTARY,LINE SEL.,DPDT,2 POS.	799551 61935 SWA003.4501	1		1
SW 2		SWITCH,ROCKER,DPST	800649 62440 232KW20B2C	1		1
TM 1		9100 SERIES GETTING STARTED MANUAL	787960 89536 787960	1		
TM 2		9100 SERIES AUTOMATED OPERATIONS MAN	809228 89536 809228	1		
TM 3		9100 SERIES TECHNICAL USER'S MANUAL	813832 89536 813832	1		
TM 4		9100 SERIES APPLICATIONS MANUAL	813840 89536 813840	1		
TM 5		SUPPLEMENTAL POD INFO FOR 9100A/9105A	822866 89536 822866	1		
W 3		CABLE, A C POWER CONNECT	749903 89536 749903	1		
W 4		CABLE ASSEMBLY, LINE SELECT	773267 89536 773267	1		
W 5		LINE FILTER ASSEMBLY	773424 89536 773424	1		
W 6		CABLE, PROBE I/O INTERFACE	773432 89536 773432	2		
W 7		CABLE,DISK DRIVE	773846 89536 773846	1		8
W 8		CABLE,DISPLAY INTERFACE	773853 89536 773853	1		
W 9		CABLE,KEYPAD INTERFACE	773861 89536 773861	1		
W 10		CABLE ASSEMBLY, D C HARNESS	773887 89536 773887	1		
W 11		CABLE ASSY, CLOCK MODULE	783969 89536 783969	1		
W 12		CABLE ASSEMBLY, RS232 M	787838 89536 787838	2		
W 13		CABLE ASSEMBLY, HARD DISK TO MFI	787895 89536 787895	1		1
W 15		CABLE, HARD DISK TO CONTROLLER	788448 89536 788448	1		1
W 16		CABLE, HARD DISK TO CONTROL DATA	788455 89536 788455	1		1
W 17		FAN ASSEMBLY	788471 89536 788471	1		
W 18		CABLE ASSEMBLY, BNC	801944 89536 801944	1		
W 19		CABLE ASSEMBLY, MICRO-CLIP	809178 89536 809178	1		
W 21		CABLE, DISK DRIVE POWER	788430 89536 788430	1		9
XF 1		HLDR PART,FUSE,BODY 1/4X1-1/4,5X20MM	460329 61935 031.1673	1		

An * in 'S' column indicates a static-sensitive part.

NOTES:

- 1 - Not used on 9105A.
- 2 - For 9105A, quantity is 2.
- 3 - For 9105A S/Ns prior to 4352000, two 512K + two 256K (799833) were used.
- 4 - For 9105A, order p/n 805721.
- 5 - For 9105A, order p/n 805713, quantity 2.
- 6 - For 9105A, order p/n 787853.
- 7 - For 9105A, order p/n 788521.
- 8 - For 9105A, order p/n 788547.
- 9 - For 9105A, order p/n 805705.
- 10 - For 9105A, order p/n 802009.

A101 through A105 are Original Equipment Manufacturer (OEM) assemblies. List of replaceable parts is not available.

5/List of Replaceable Parts

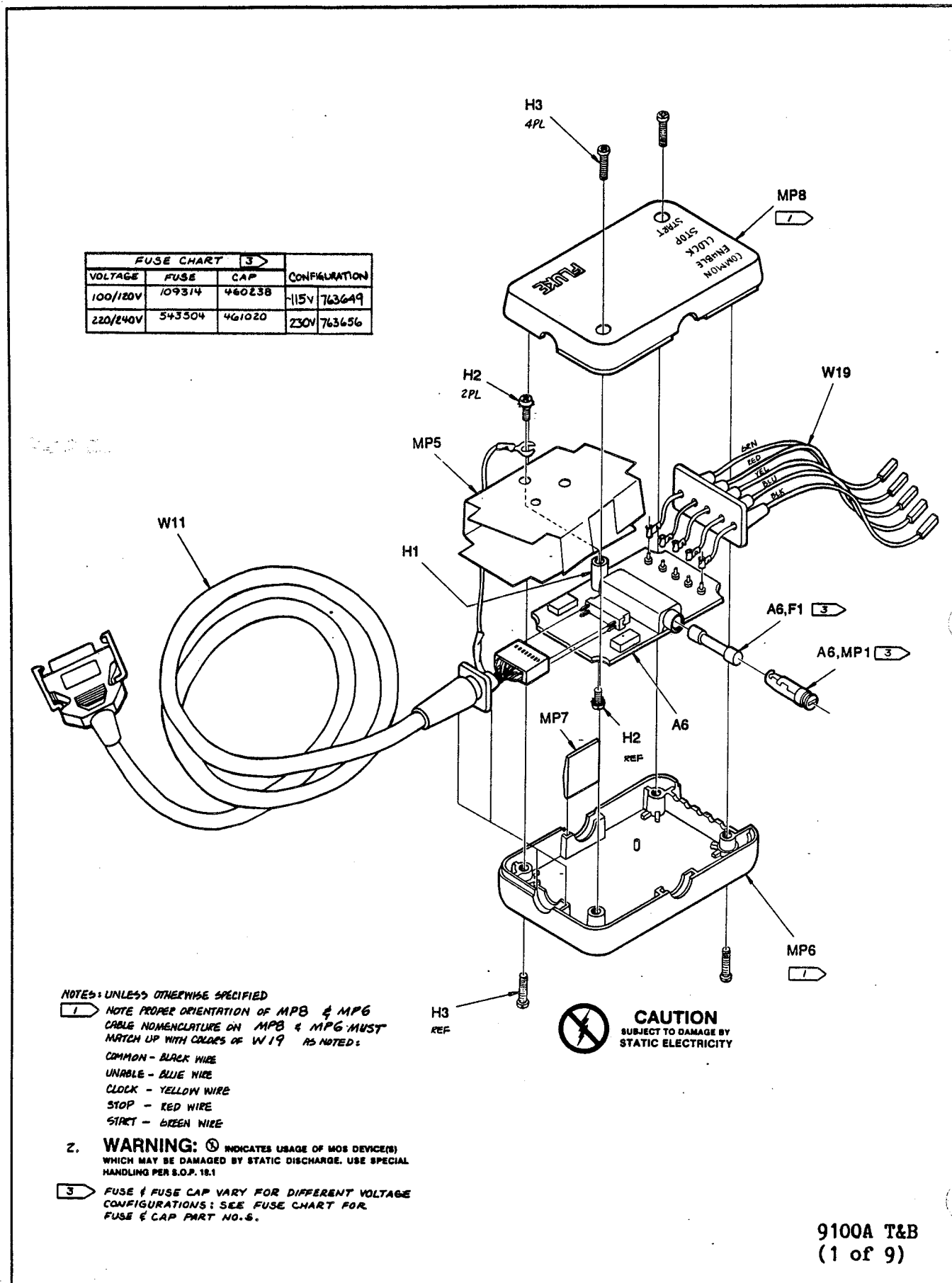
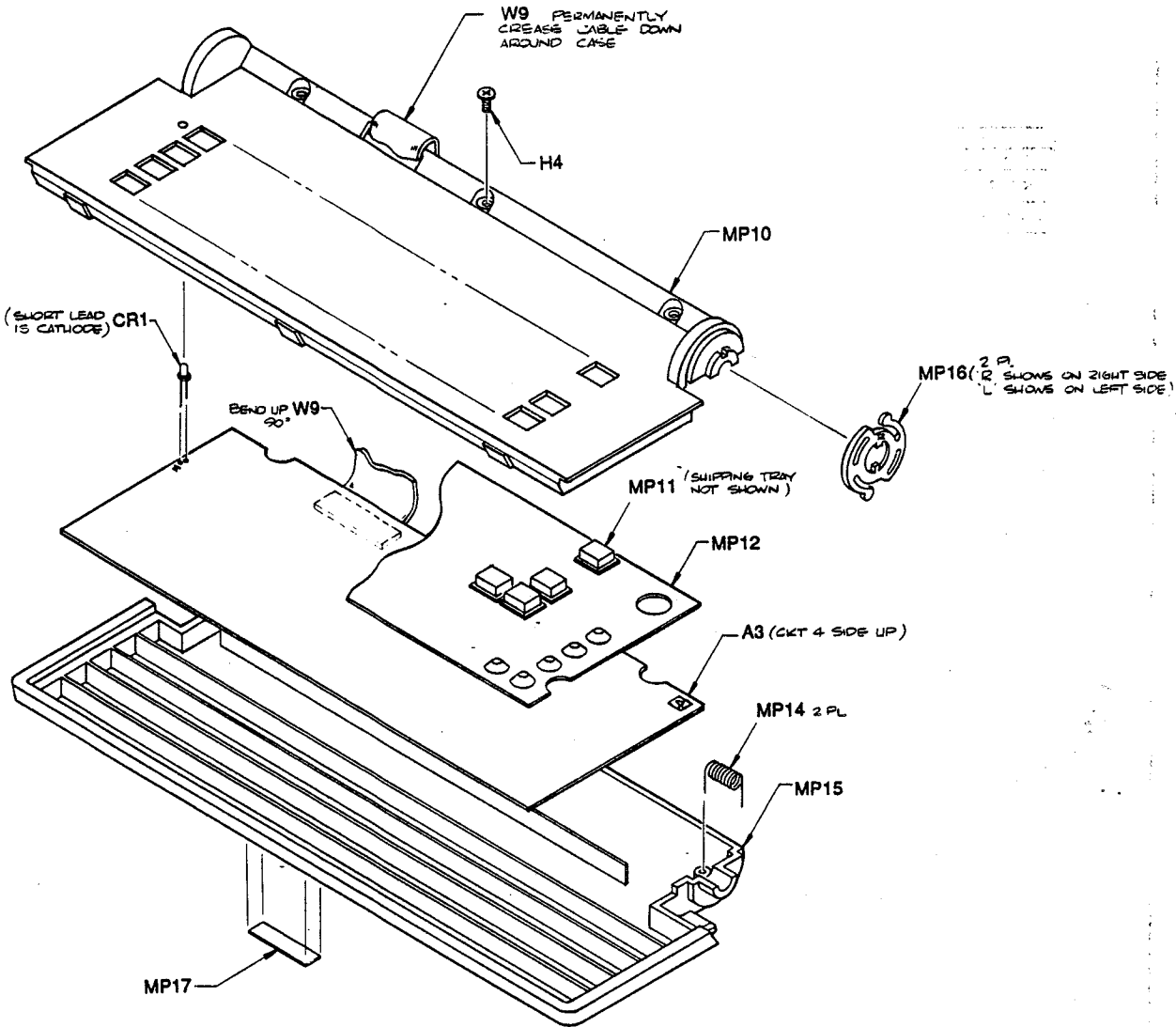

Figure 5-1. 9100 Series Final Assembly



9100A T&B
(2 of 9)

Figure 5-1. 9100 Series Final Assembly (cont.)

5/List of Replaceable Parts

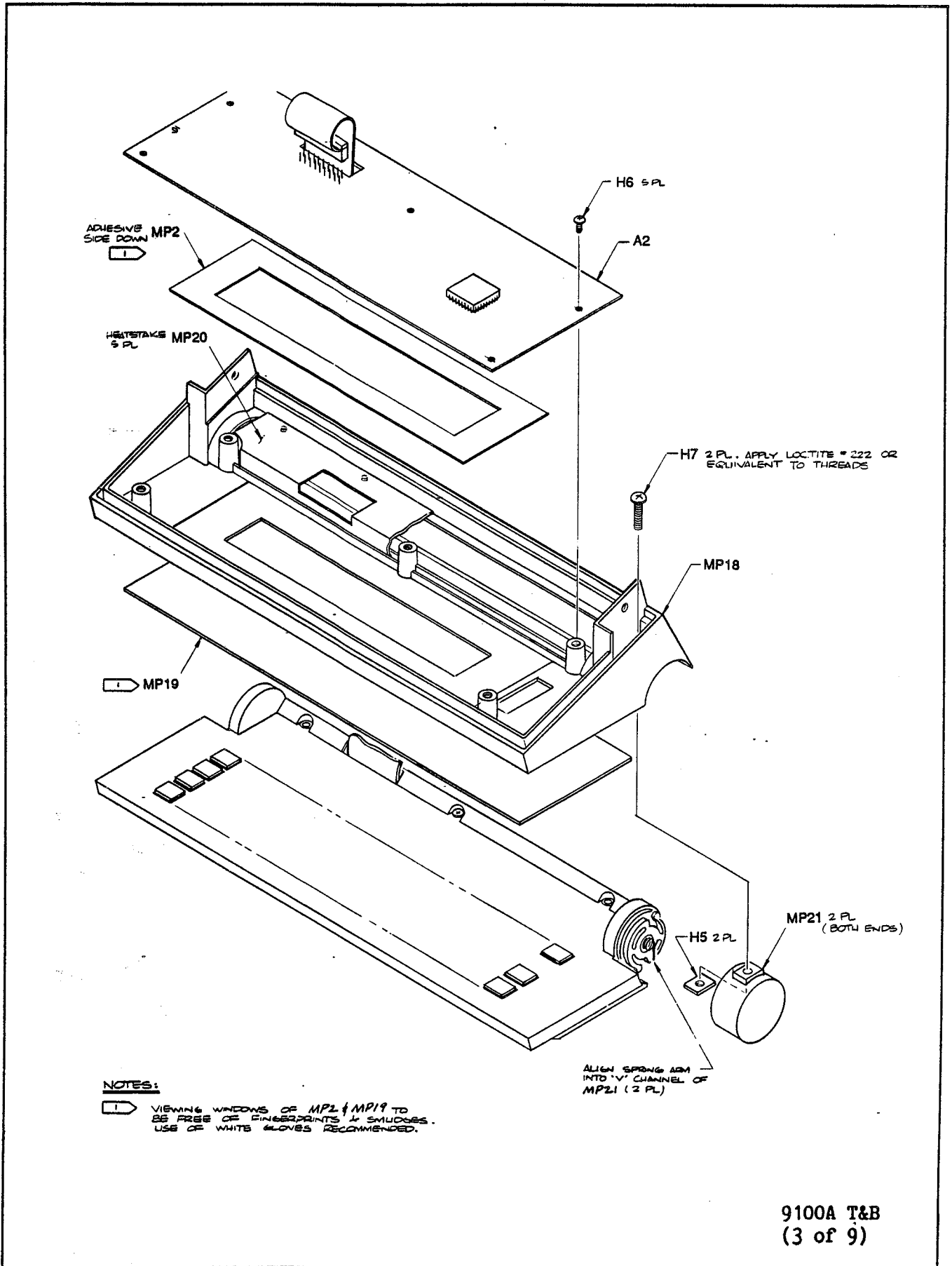
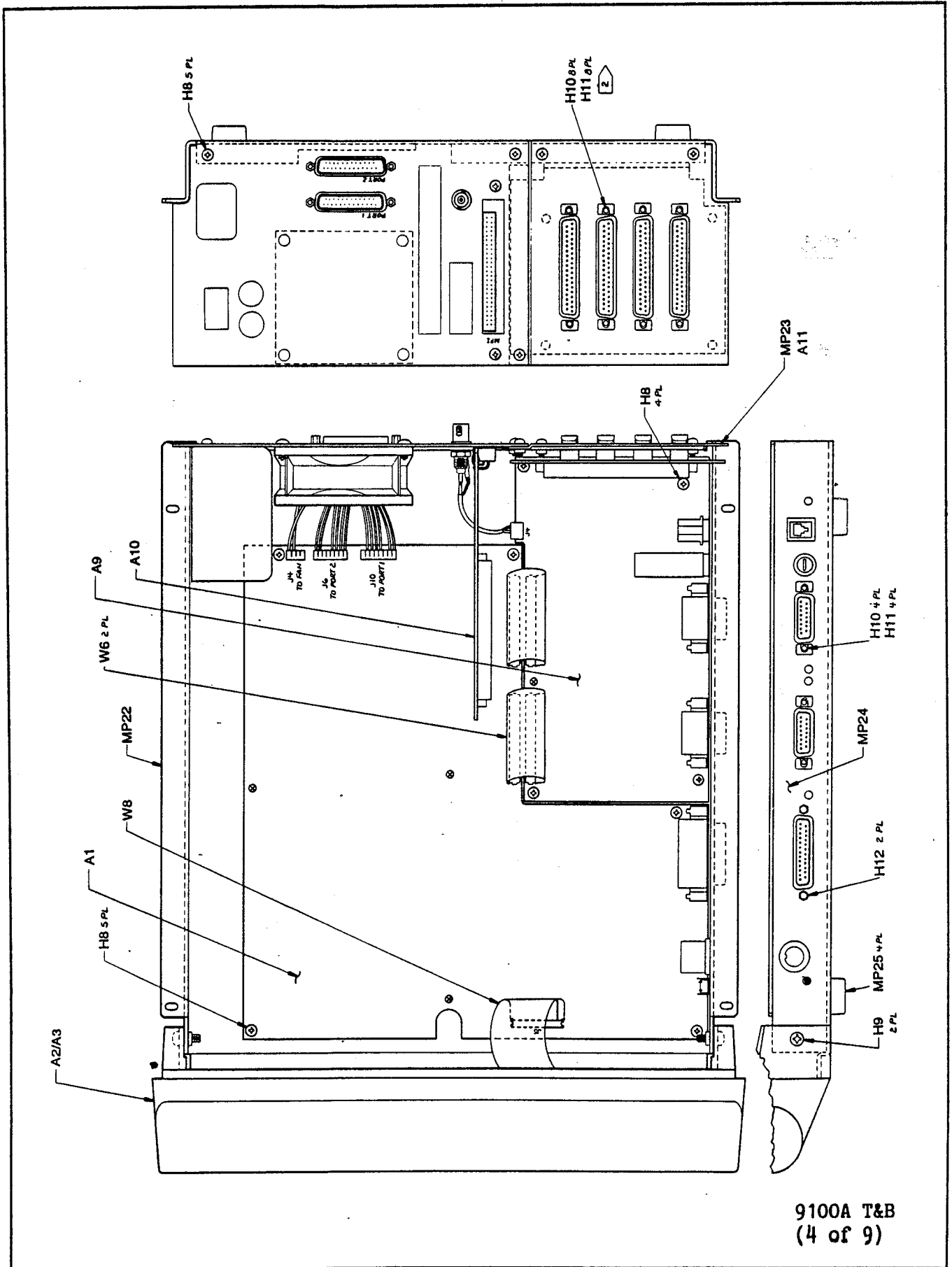

Figure 5-1. 9100 Series Final Assembly (cont.)



9100A T&B
(4 of 9)

Figure 5-1. 9100 Series Final Assembly (cont.)

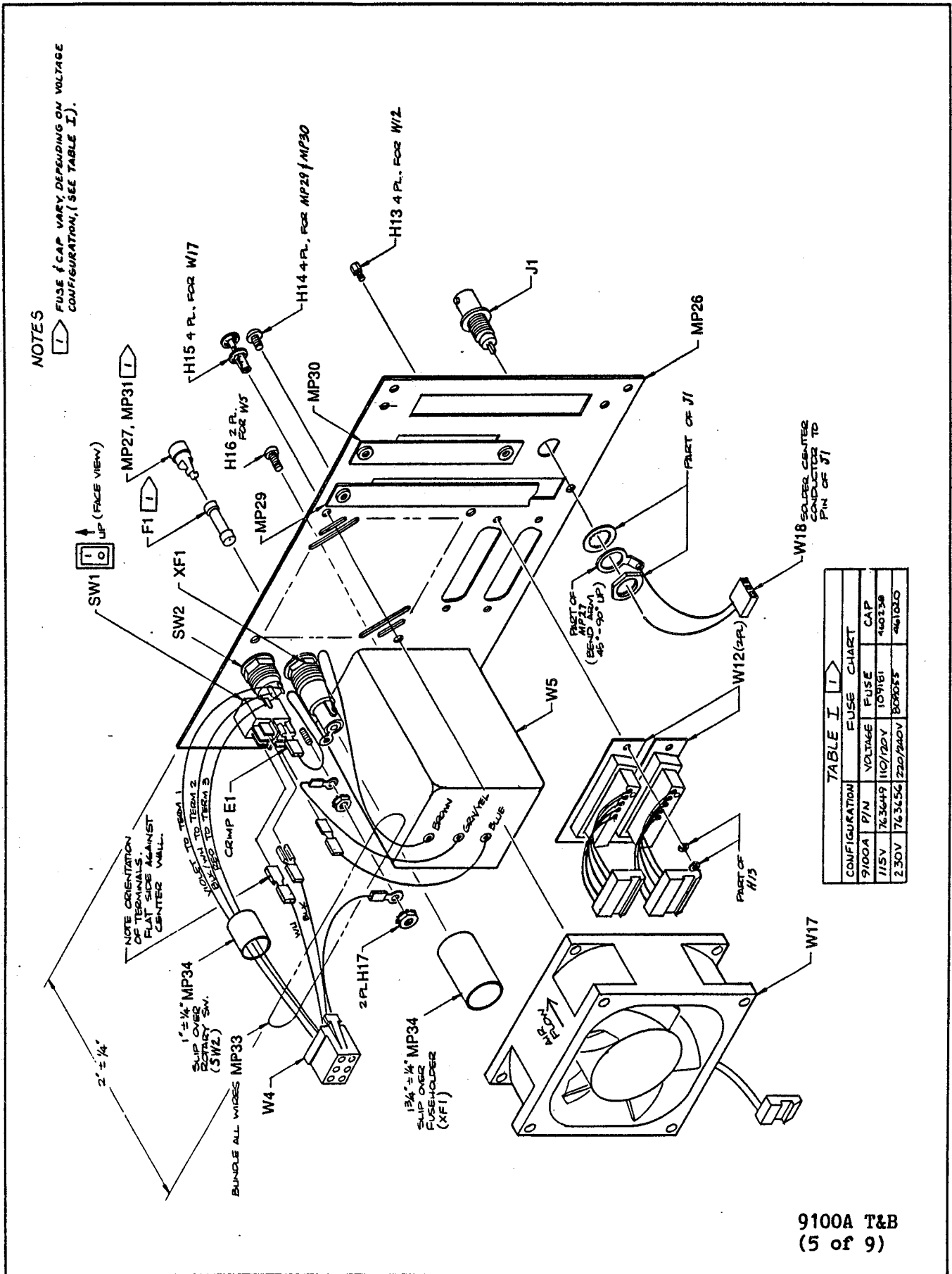
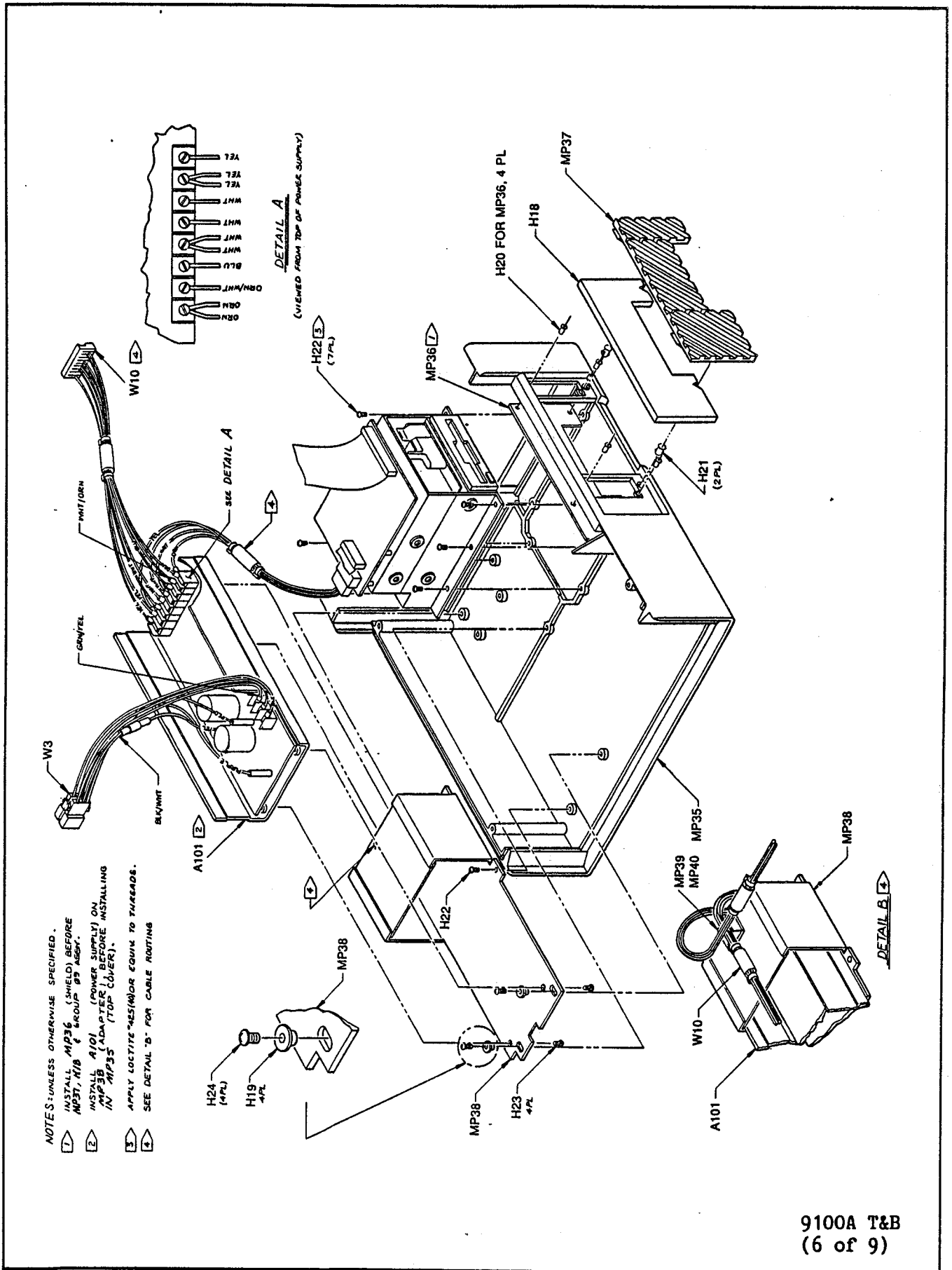

Figure 5-1. 9100 Series Final Assembly (cont.)



9100A T&B
(6 of 9)

Figure 5-1. 9100 Series Final Assembly (cont.)

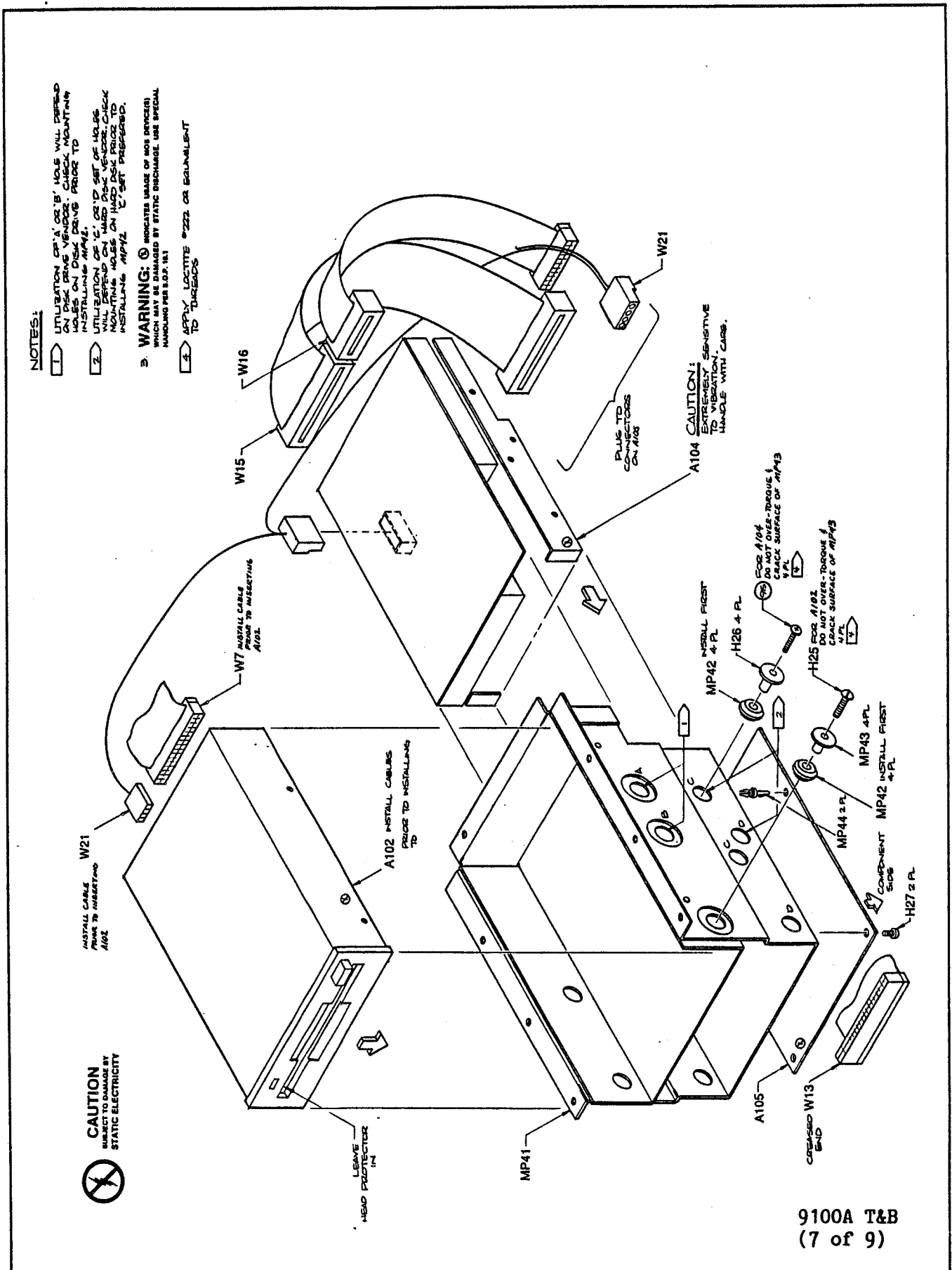

Figure 5-1. 9100 Series Final Assembly (cont.)

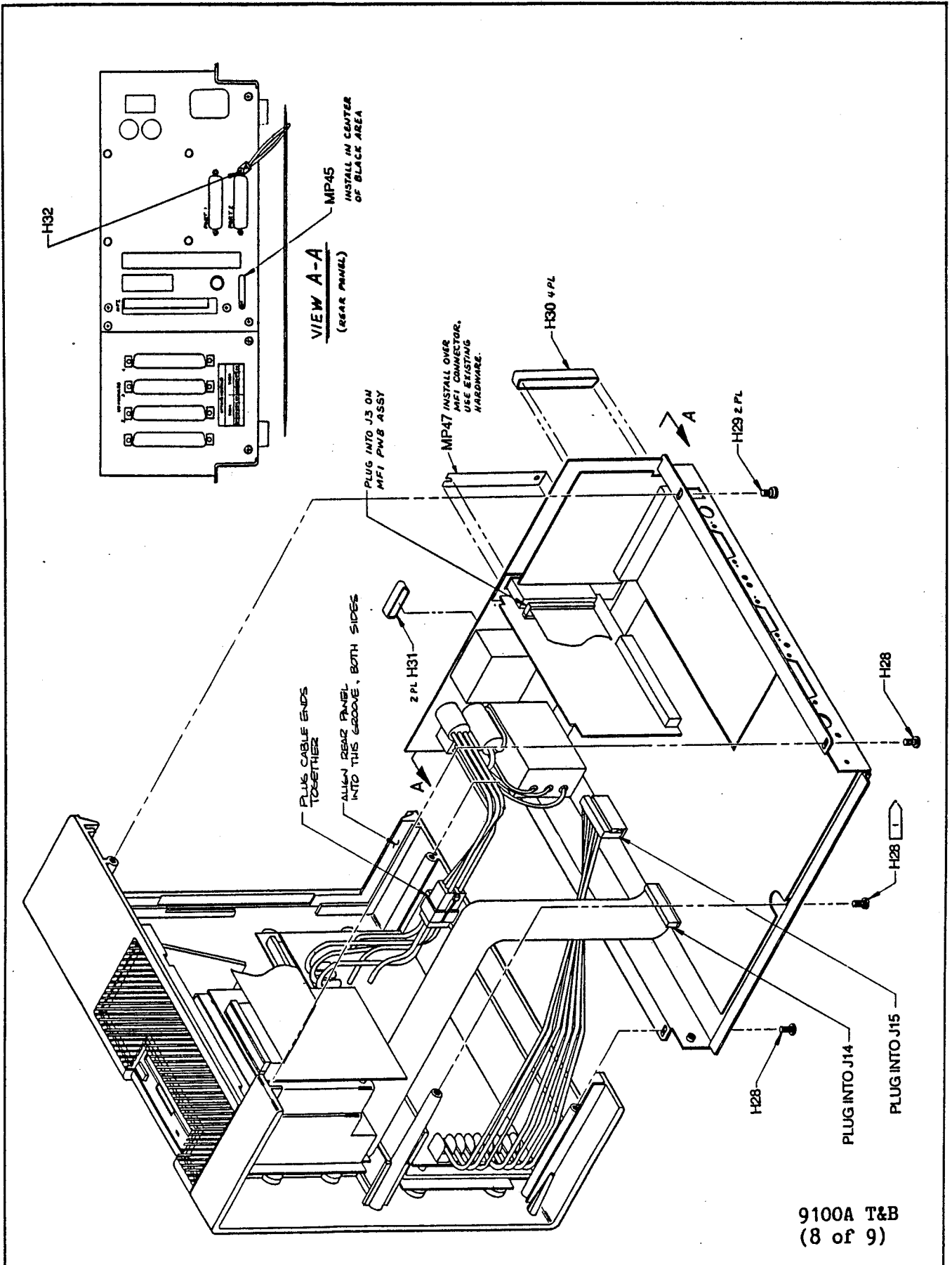

Figure 5-1. 9100 Series Final Assembly (cont.)

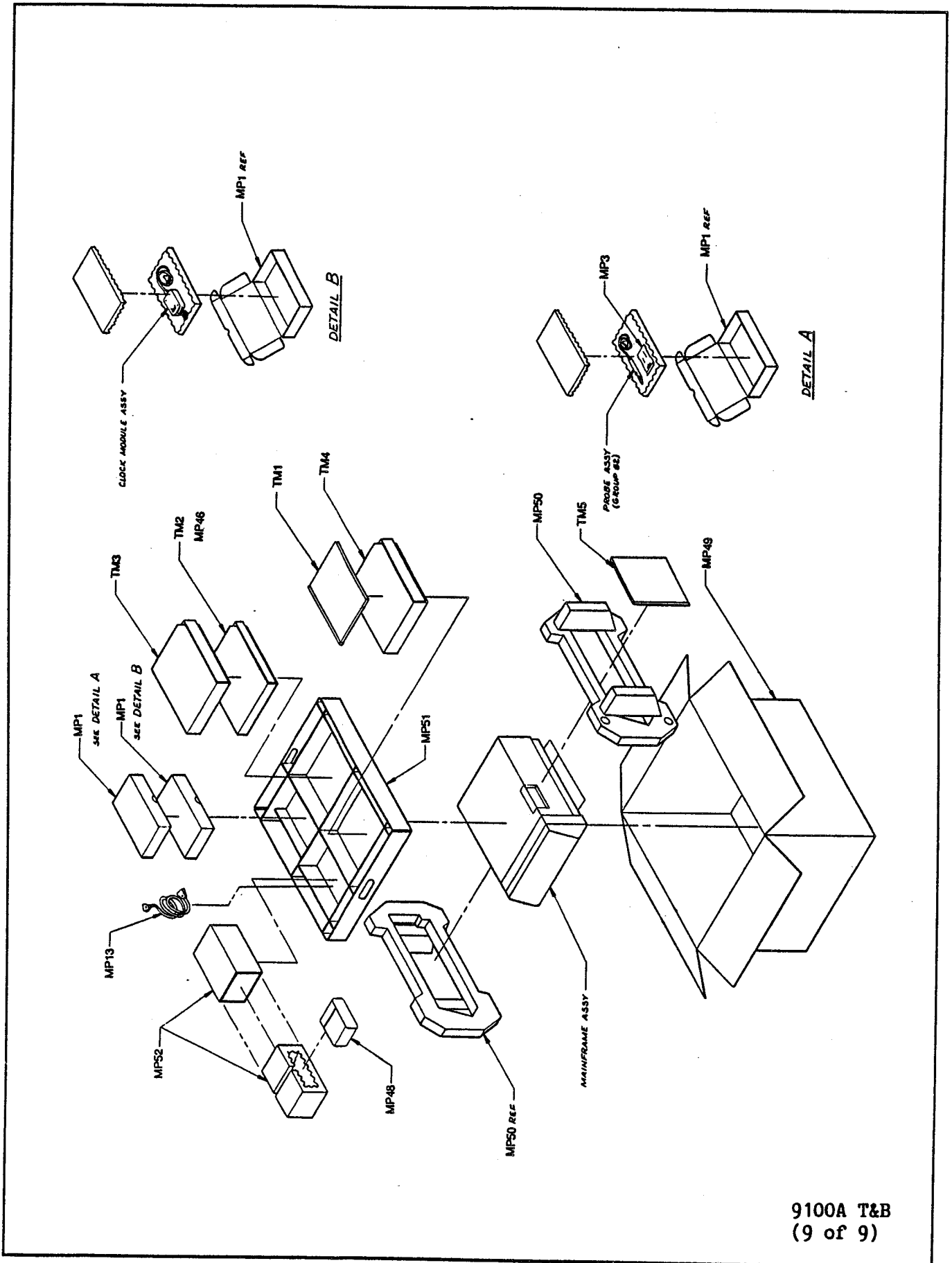

Figure 5-1. 9100 Series Final Assembly (cont.)

5/List of Replaceable Parts

Table 5-3. A1 Main PCA
(See Figure 5-2.)

REFERENCE DESIGNATOR	FLUKE STOCK	MFRS SPLY	MANUFACTURERS PART NUMBER	TOT QTY	R S T	N O T
-A>-NUMERICS-->	S-----DESCRIPTION-----	--NO--	-CODE- -OR GENERIC TYPE-----	-QTY-	-Q-	-E-
C 1- 4, 6, 23, 100-103	CAP, TA, 10UF, +-20%, 25V	772491	56289 195D106X0025Y2B	10		
C 5	CAP, TA, 3.3UF, +-20%, 25V	780486	56289 195D335X0025X2B	1	1	
C 10, 11, 18, 19, 24, 110-113, 120, 121, 130, 131, 200-288, 300-310, 320, 321, 340-343, 360, 361	CAP, CER, 0.01UF, +-10%, 50V, X7R, 1206	747261	72982 GRM426X7R103K50VBP	121		
C 12	CAP, CER, 1000PF, +-10%, 50V, COG, 1206	747378	72982 GRM426COG102K50VBP	1		
C 13	CAP, CER, 0.1UF, +-10%, 25V, X7R, 1206	747287	72982 GRM426X7R104K25VBP	1		
C 14	CAP, CER, 10PF, +-10%, 50V, COG, 1206	747311	72982 GRM426COG100K50VBP	1		
C 16, 17, 20, 21	CAP, CER, 47PF, +-10%, 50V, COG, 1206	747352	72982 GRM426COG470K50VBP	4		
C 380	CAP, CER, 0.01UF, +-20%, 100V, X7R, 1206	742981	72982 GRM426X7R103M100VBP	1		
CR 1- 3, 6- 8	DIODE, SI, BV=200V, IO=10A, DUAL, SOT89	742973	25088 BAW79CE6327	6	1	
CR 4, 5	DIODE, SI, BV=75.0V, IO=100MA, MLF	742064	73445 BAS32	2	2	
CR 9, 10	DIODE, SI, SCHOTTKY, 30V, 1.1A, SOT89	782573	61752 10JQ030TRRM	2	1	
F 1	FUSE, 5X20MM, FAST, 0.125A, 250V	573733	61935 216.125	1	5	
J 1	HEADER, 1 ROW, 0.100CTR, 4 PIN	631184	00779 640456-4	1		
J 2, 3	HEADER, 1 ROW, 0.100CTR, 8 PIN	520502	22526 65502-408	2		
J 4, 6	CONN, DIN41612, TYPE R, 96 PIN	747808	00779 532523-1	2		
J 5	CONN, DIN41612, TYPE R, 64 PIN	782094	00779 532523-2	1		
J 7, 8	HEADER, 2 ROW, 0.100 CTR, 40 PIN	603670	00779 2-87227-0	2		
J 9	CONN, D-SUB, PWB, RT ANG, 25 SCKT	782144	00779 747846-4	1		
J 10	CONN, CIRC, DIN, RT ANG, PWB, 5 PIN @ 180	772178	00779 211450-1	1		
J 11	HEADER, 2 ROW, 0.100CTR, 20 PIN	782185	00779 1-87227-0	1		
J 14	HEADER, 2 ROW, 0.100CTR, 34 PIN	658047	00779 1-87227-7	1		
J 15	HEADER, 1 ROW, 0.156 CTR, 10 PIN	446724	27264 09-65-1101	1		
L 1, 2	CHOKE	502138	89536 502138	2		
Q 1, 2	* TRANSISTOR, SI, N-MOS, 1W, 4 PIN DIP	800391	17856 V11974	2	1	
R 1	RES, CHIP, CERM, 56K, +-5%, 0.125W, 1206	746701	09969 CRCW1206563JB02	1		
R 2, 3, 6, 7, 11- 15, 27- 29, 31- 35, 40, 43, 45- 48, 56- 63, 67, 70, 75, 76, 80, 83- 85, 87, 89, 90	RES, CHIP, CERM, 10K, +-5%, 0.125W, 1206	746610	09969 CRCW1206103JB02	42		
R 4, 100-111, 116	RES, CHIP, CERM, 10, +-5%, 0.125W, 1206	746214	09969 CRCW1206100JB02	14		
R 5, 8- 10, 21, 22, 30, 65, 69, 72, 82, 86	RES, CHIP, CERM, 4.7K, +-5%, 0.125W, 1206	740522	09969 CRCW1206472JB02	12		
R 16, 17, 51- 55, 71, 78, 88	RES, CHIP, CERM, 1.2K, +-5%, 0.125W, 1206	740522	09969 CRCW1206122JB02	10		
R 18, 19, 36, 37, 74	RES, CHIP, CERM, 39K, +-5%, 0.125W, 1206	746677	09969 CRCW1206393JB02	5		
R 20, 38, 77	RES, CHIP, CERM, 3K, +-5%, 0.125W, 1206	746511	09969 CRCW1206302JB02	3		
R 23, 24	RES, CHIP, CERM, 390, +-5%, 0.125W, 1206	740498	09969 CRCW1206391JB02	2		
R 25, 26	RES, CHIP, CERM, 220, +-5%, 0.125W, 1206	746347	09969 CRCW1206221JB02	2		
R 39, 44, 79	RES, CHIP, CERM, 750, +-5%, 0.125W, 1206	746404	09969 CRCW1206751JB02	3		
R 41, 64, 66, 68, 91, 112- 115	RES, CHIP, CERM, 33, +-5%, 0.125W, 1206	746248	09969 CRCW1206330JB02	9		
R 42, 73	RES, CHIP, CERM, 100K, +-5%, 0.125W, 1206	740548	09969 CRCW1206104JB02	2		
R 49, 50	RES, CHIP, CERM, 510K, +-5%, 0.125W, 1206	746800	09969 CRCW1206514JB02	2		
R 81	RES, CHIP, CERM, 2.2K, +-5%, 0.125W, 1206	746479	09969 CRCW1206222JB02	1		
S 1	SWITCH, PUSHBUTTON, SPST, MOMENTARY	782433	5N615 B3F-3122	1		
T 1	TRANSFORMER, CONVERTER	775932	89536 775932	1		
TP 1- 11	TERM, UNINSUL, WIRE FORM, TEST POINT	781237	27918 TP102-I	11		
U 1, 4	* IC, BIPOLAR, DUAL RS-232 RECEIVER, SOIC	742395	01295 SN75152D	2	1	
U 2, 3	* IC, BIPOLAR, DUAL RS-232 DRIVER, SOIC	742403	01295 SN75150DR	2	1	
U 5, 6	* ISOLATOR, HI-SPEED DUAL	742841	28480 HCPL2531, OPTION100	2	1	

An * in 'S' column indicates a static-sensitive part.

5/List of Replaceable Parts

Table 5-3. A1 Main PCA (cont.)

REFERENCE DESIGNATOR	FLUKE STOCK	MFRS SPLY	MANUFACTURERS PART NUMBER	TOT QTY	R S	O T	N
-A>-NUMERICS--> S-----DESCRIPTION-----	--NO--	-CODE-	--OR GENERIC TYPE-----	QTY-	-Q-	-E-	
U 8, 35	* IC, LSTTL, HEX INVERTER, SOIC	741017	18324 N74LS04DT	2	1		
U 9	* IC, CMOS, OCTL LINE DRVR, SOIC	742593	18324 N74HCT244DT	1	1		
U 10	* IC, LSTTL, 8BIT P/S-IN, S-OUT SHFT, SOIC	741983	01295 SN74LS165ADR	1	1		
U 11	* IC, NMOS, EEPROM 2444	834416	89536 834416	1	1		
U 13- 16	* ASSEMBLY, RAM MODULE	809079	89536 809079	4			1
U 17	* IC, ALSTTL, 3-8 LINE DCDR W/ENABLE, SOIC	741686	01295 SN74ALS138DR	1	1		
U 18	OSCILLATOR, 32MHZ, TTL CLOCK	742338	01537 K1100AM	1			
U 19	* IC, FTTL, DUAL D F/F, +EDG TRG, SOIC	742163	18324 74F74DT	1	1		
U 20	* IC, ASTTL, QUAD 2 INPUT NAND GATE, SOIC	782250	01295 SN74AS00DR	1	1		
U 21, 57	* IC, ALSTTL, QUAD 2 INPUT AND GATE, SOIC	741827	01295 SN74ALS08DR	2	1		
U 22, 41, 82	* IC, LSTTL, QUAD 2 INPUT OR GATE, SOIC	740878	18324 N74LS32D	3	1		
U 23, 24	* IC, FTTL, 9 BIT PARITY GEN/CHECKER, SOIC	742478	18324 N74F280ADT	2	1		
U 25, 91	* IC, ALSTTL, QUAD 2 INPUT NAND GATE, SOIC	782268	01295 SN74ALS00ADR	2	1		
U 26	* IC, LSTTL, 8-BIT BINARY CNTR W/REG, SOIC	782243	01295 SN74LS590DR	1	1		
U 27	* IC, LSTTL, OCTAL BUFFER INVERTED, SOIC	742627	18324 N74LS240DT	1	1		
U 28	* IC, 16L8 LOGIC ARRAY	818203	7J696 AMPAL16LSLPC	1	1		
U 29- 31	* IC, ASTTL, QUAD 2-INPUT MUX, SOIC	811984	01295 SN74AS257DR	3	1		
U 32	* IC, NMOS, 16 BIT MICROPROCESSOR, PLCC	742429	18324 SCN6800C8A68T	1	1		
U 33	* IC, LSTTL, QUAD BUS, SOIC	740977	18324 N74LS125ADT	1	1		
U 34, 54	* IC, LSTTL, DUAL 4 INPUT NAND GATE, SOIC	742528	18324 N74LS20DT	2	1		
U 36, 67, 74	* IC, ALSTTL, QUAD 2 INPUT NOR GATE, SOIC	782284	01295 SN74ALS02DR	3	1		
U 37, 61- 63	* IC, LSTTL, OCTAL D F/F, +EDG TRG, SOIC	741975	18324 N74LS374DT	4	1		
U 38, 89	* IC, ALSTTL, HEX INVERTERS, SOIC	782300	01295 SN74ALSBDR	2	1		
U 39	* IC, ALSTTL, QUAD 2 INPUT OR GATE, SOIC	742460	01295 SN74ALS32DR	1	1		
U 40, 50, 81	* IC, LSTTL, 8BIT S-IN, P-OUT R-SHFT, SOIC	742106	18324 NN74LS164DT	3	1		
U 42, 58	* IC, LSTTL, OCTL LINE DRVR, SOIC	742122	18324 N74LS244DT	2	1		
U 43	* IC, NMOS, FLOPPY DISK FORMTR CNTLR, PLCC	782870	53848 FDC179702LJP	1	1		
U 44	* IC, NMOS, FLOPPY DISK INT CKT, PLCC	782888	53848 FDC9229B/TLJP	1	1		
U 46	* PROGRAMMED 27256 V3.0	828897	89536 828897	1	1		
U 47	* PROGRAMMED 27256 V3.0	828905	89536 828905	1	1		
U 49, 75	* IC, LSTTL, 8 TO 3 LINE ENCODER, SOIC	782326	01295 SN74LS148DR	2	1		
U 51, 64	* IC, LSTTL, QUAD 2 INPUT NAND GATE, SOIC	741033	18324 N74LS00DT	2	1		
U 52	* IC, LSTTL, TRIPLE 3-INPUT AND GATE, SOIC	741264	18324 N74LS10D	1	1		
U 53, 60	* IC, LSTTL, OCTAL D F/F, +EDG TRG, SOIC	740928	18324 N74LS273DT	2	1		
U 55, 90	* IC, ALSTTL, 8 INPUT NAND GATE, SOIC	782334	01295 SN74ALSADR	2	1		
U 56, 65, 78	* IC, LSTTL, QUAD 2 INPUT NOR GATE, SOIC	741025	18324 N74LS02DT	3	1		
U 59	* IC, COMPARATOR, QUAD, 14 PIN, SOIC	741561	18324 LM339DT	1	1		
U 66	* IC, LSTTL, TRIPLE 3 INPUT NOR GATE, SOIC	740993	18324 N74LS27D	1	1		
U 68	* IC, ALSTTL, DUAL 4 INPUT NAND GATE, SOIC	741645	01295 SN74ALS20ADR	1	1		
U 69	* IC, ALSTTL, TRIPLE 3INPUT NOR GATE, SOIC	782318	01295 SN74ALS27DR	1	1		
U 70	* IC, LSTTL, 2-4 LINE DEMUX, SOIC	740951	18324 N74LS139D	1	1		
U 71	* IC, CMOS, HEX INVERTER W/SCHT TRIG, SOIC	780965	18324 N74HCT14DT	1	1		
U 72	* IC, TTL, HEX BUFFER W/OPEN COLL, SOIC	742387	18324 N7417DT	1	1		
U 73	* IC, LSTTL, DUAL JK F/F, -EDG TRIG, SOIC	741256	18324 N74LS112DT	1	1		
U 76	* IC, LSTTL, QUAD 2IN O/C NAND GATE, SOIC	782292	01295 SN74LS03DR	1	1		
U 77, 80	* IC, LSTTL, DUAL D F/F, +EDG TRG, SOIC	740985	18324 S74LS74ADT	2	1		
U 79	* IC, ALSTTL, DUAL D F/F, +EDG TRG, SOIC	742452	01295 SN74ALS74ADR	1	1		
U 83	SWITCH, MODULE, SPST, DIP, 8 POS	414490	00779 435166-5	1			
U 84	* IC, LSTTL, QUAD 2 INPUT AND GATE, SOIC	740860	18324 N74LS08DT	1	1		
U 85	* IC, LSTTL, DUAL J-F F/F, +EDG TRIG, SOIC	742502	01295 SN74LS109ADT	1	1		
U 86	* IC, LSTTL, DELAY ELEMENTS, SOIC	773077	01295 SN74LS31DR	1	1		
U 87	* IC, VOLT SUPERVISOR, 10V SENSE, SOIC	780502	01295 TL7705ACDR	1	1		
U 88	* IC, LSTTL, MONOSTAB MULTIVB W/CLR, SOIC	742494	01295 SN74LS123DR	1	1		
XF 1	HOLDER, FUSE, 5X20MM, PCB	772475	7E222 111501	2			
XU 13- 16	CONN, PWB EDGE, REC, 0.100CTR, 30 POS	806828	00779 821828-2	4	1		
XU 18	SPACER, DIP SOCKET, 14 PIN, PLASTIC	441865	32559 814-060	1			
XU 28	SOCKET, IC, 20 PIN	454421	09922 DILB20P-108	1			
XU 45- 48	SOCKET, IC, 28 PIN	448217	91506 328-AG39D	4			
Y 1	CRYSTAL, 3.6864MHZ, +/-50PPM, SURF.MNT.	800193	5W664 CP41A	1	1		

An * in 'S' column indicates a static-sensitive part.

NOTES:

1 - See A16 on the Final Assembly for quantities and part numbers.

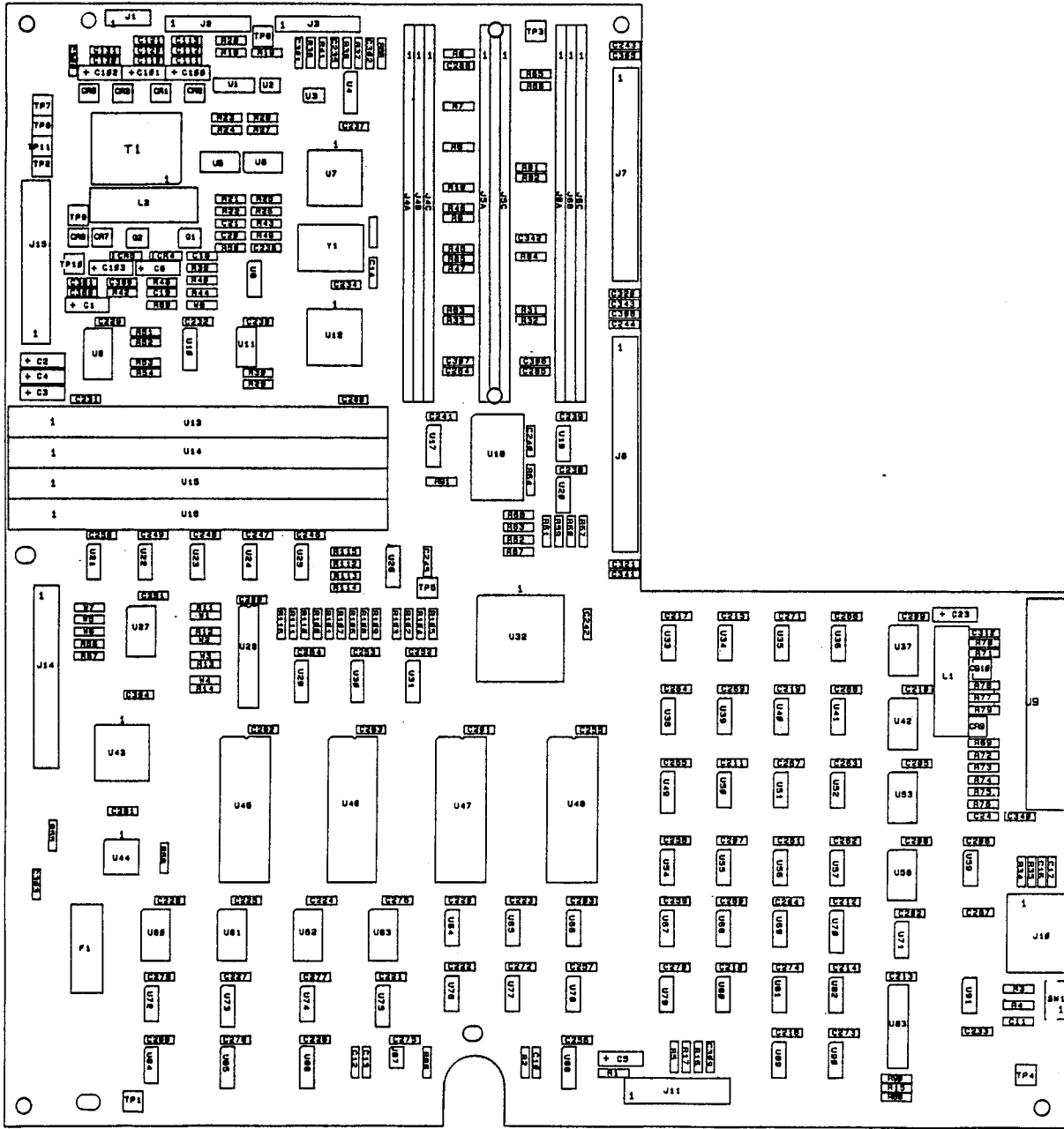

9100A-1601

Figure 5-2. A1 Main PCA

Table 5-4. A2 Display Interface PCA
(See Figure 5-3.)

REFERENCE DESIGNATOR	NUMERICS	DESCRIPTION	FLUKE STOCK	MFRS SPLY	MANUFACTURERS PART NUMBER	TOT QTY	R S T	N O E
-A>	->	-S	-NO-	-CODE-	-OR GENERIC TYPE----	-QTY-	-Q	-E-
C	1, 8	CAP, CER, 5.6PF, +-10%, 50V, COG, 1206	782409	72982	GRM42-6COG5R6K50VPB	2		
C	2	CAP, TA, 1.5UF, +-20%, 50V	780478	56289	195D155X0050X2B	1	1	
C	3, 4	CAP, TA, 10UF, +-20%, 25V	772491	56289	195D106X0025X2B	2		
C	5, 70- 78,	CAP, CER, 0.01UF, +-20%, 100V, X7R, 1206	742981	72982	GRM426X7R103M100VPB	41		
C	101-131		742981					
C	6, 7	CAP, CER, 0.1UF, +-10%, 25V, X7R, 1206	747287	72982	GRM426X7R104K25VPB	2		
CR	1- 7	LED, RED, RECTANGLE, PCB MOUNT	504761	14936	MV57124	7	2	
E	1	AF TRANSO, PIEZO, 24 MM	602490	51406	EFB-RD24C01	1		
J	1, 2	HEADER, 2 ROW, 0.100CTR, 20 PIN	782185	00779	1087227-0	2		
MP	1	DISPLAY ALIGNMENT FIXTURE	788570	89536	788570	1		
Q	1- 4	TRANSISTOR, SI, PNP, SMALL SIGNAL, SOT23	742023	73445	BCX17TRL	4	1	
Q	5- 8	TRANSISTOR, SI, NPN, SMALL SIGNAL, SOT23	742031	73445	BCX19TRL	4	1	
R	1- 4, 6-	RES, CHIP, CERM, 1.1K, +-5%, 0.125W, 1206	746008	09969	CRCW1206112JB02	16		
R	13, 15, 16,		746008					
R	48, 49		746008					
R	5	RES, CHIP, CERM, 100K, +-5%, 0.125W, 1206	740548	09969	CRCW1206104JB02	1		
R	14, 17	RES, CHIP, CERM, 6.8K, +-5%, 0.125W, 1206	746024	09969	CRCW1206682JB02	2		
R	18, 19	RES, CHIP, CERM, 620, +-5%, 0.125W, 1206	745984	09969	CRCW1206621JB02	2		
R	20	RES, CHIP, CERM, 330, +-5%, 0.125W, 1206	746370	09969	CRCW1206331JB02	1		
R	21	RES, CHIP, CERM, 470, +-5%, 0.125W, 1206	740506	09969	CRCW1206471JB02	1		
R	22- 29	RES, CHIP, CERM, 10K, +-5%, 0.125W, 1206	746610	09969	CRCW1206103JB02	8		
R	30, 31	RES, CHIP, CERM, 6.2K, +-5%, 0.125W, 1206	746016	09969	CRCW1206622JB02	2		
R	32, 42- 47	RES, CHIP, CERM, 180, +-5%, 0.125W, 1206	746321	09969	CRCW1206181JB02	7		
R	33, 34, 41,	RES, CHIP, CERM, 4.7K, +-5%, 0.125W, 1206	740522	09969	CRCW1206472JB02	4		
R	50		740522					
R	35, 36	RES, CHIP, CERM, 100, +-5%, 0.125W, 1206	746297	09969	CRCW1206101JB02	2		
R	37	RES, CHIP, CERM, 3K, +-5%, 0.125W, 1206	746511	09969	CRCW1206511JB02	1		
R	38	RES, CHIP, CERM, 7.5K, +-5%, 0.125W, 1206	746586	09969	CRCW1206752JB02	1		
R	39	RES, CHIP, CERM, 2K, +-5%, 0.125W, 1206	746461	09969	CRCW1206202JB02	1		
R	40	RES, CHIP, CERM, 1.8K, +-5%, 0.125W, 1206	746453	09969	CRCW1206182JB02	1		
TP	1- 7	TERM, UNINSUL, WIRE FORM, TEST POINT	781237	26364	TP10201	7		
U	1	IC, NMOS, 8 BIT MICROCOMP W/SOCKET	800607	56708	Z086132RSE	1	1	
U	1	PROGRAMMED 2732-2 V1.0	818187	89536	818187	1	1	
U	2	IC, LSTTL, OCTAL D F/F, +EDG TRG, SOIC	741975	18324	N74LS374DT	1	1	
U	3	IC, 2K X 8 STATIC RAM, 120NSEC, SOIC	742783	8V413	CXK5816M-12L	1	2	
U	4	IC, LSTTL, DUAL DIV BY 2, 5 CNTN, SOIC	741967	18324	N74LS390DT	1	1	
U	5- 12	IC, BIMOS, DISPLAY DRIVER, 80V, PLCC	741231	56289	UCN5818EP-1	8	2	
U	13, 14	IC, LSTTL, DUAL D F/F, +EDG TRG, SOIC	740985	18324	S74LS74ADT	2	1	
U	15, 27	IC, ALSTTL, DUAL JK F/F, -EDG TRG, SOIC	807578	12040	DM74ALS112AM	2	1	
U	16	IC, LSTTL, QUAD 2 INPUT NAND GATE, SOIC	741033	18324	N74LS00DT	1	1	
U	17, 31	IC, LSTTL, QUAD 2 INPUT NOR GATE, SOIC	741025	18324	N74LS02DT	2	1	
U	18	IC, CMOS, HEX INVERTER, SOIC	742585	18324	N74HCT040	1	1	
U	19, 20	IC, LSTTL, TRIPLE 3-INPUT AND GATE, SOIC	741264	18324	N74LS10D	2	1	
U	21	IC, LSTTL, QUAD 2 INPUT OR GATE, SOIC	740878	18324	N74LS32D	1	1	
U	22	IC, TTL, HEX INVERTER, W/OPEN COLL, SOIC	741249	18324	N7406DT	1	1	
U	23, 24	IC, CMOS, 8 BIT P/S-IN, S-OUT SHFT, SOIC	782904	18324	74HCT165DT	2	1	
U	25, 30	IC, LSTTL, OCTAL D F/F, +EDG TRG, SOIC	741769	01295	SN74ALS273DWR	2	1	
U	26	IC, LSTTL, BCD-DEC, DECODER/DRIVER, SOIC	742007	01295	SN74LS145DR	1	1	
U	28	IC, LSTTL, DIV BY 16 BINARY COUNTR, SOIC	741991	18324	N74LS163ADT	1	1	
U	29	IC, BPLR, DUAL TIMER, SOIC	741959	18324	NE556DT	1	1	
VF	1	TUBE, DISPLAY, VAC FLUOR, PATTERN DIS	742056	OBW21	DM256X26G	1		
VR	1- 2	ZENER, UNCOMP, 3.3V, 5%, 76MA, 1W, MLF	800599	01537	MLL4728AT1	2	1	
XU	1	SOCKET, IC, 40 PIN	429282	09922	DILB40P-108	1		
Y	1	CRYSTAL, 9.8304MHZ, +-50PPM, SURFACE MT.	800383	5W664	CP41A	1		

An * in 'S' column indicates a static-sensitive part.

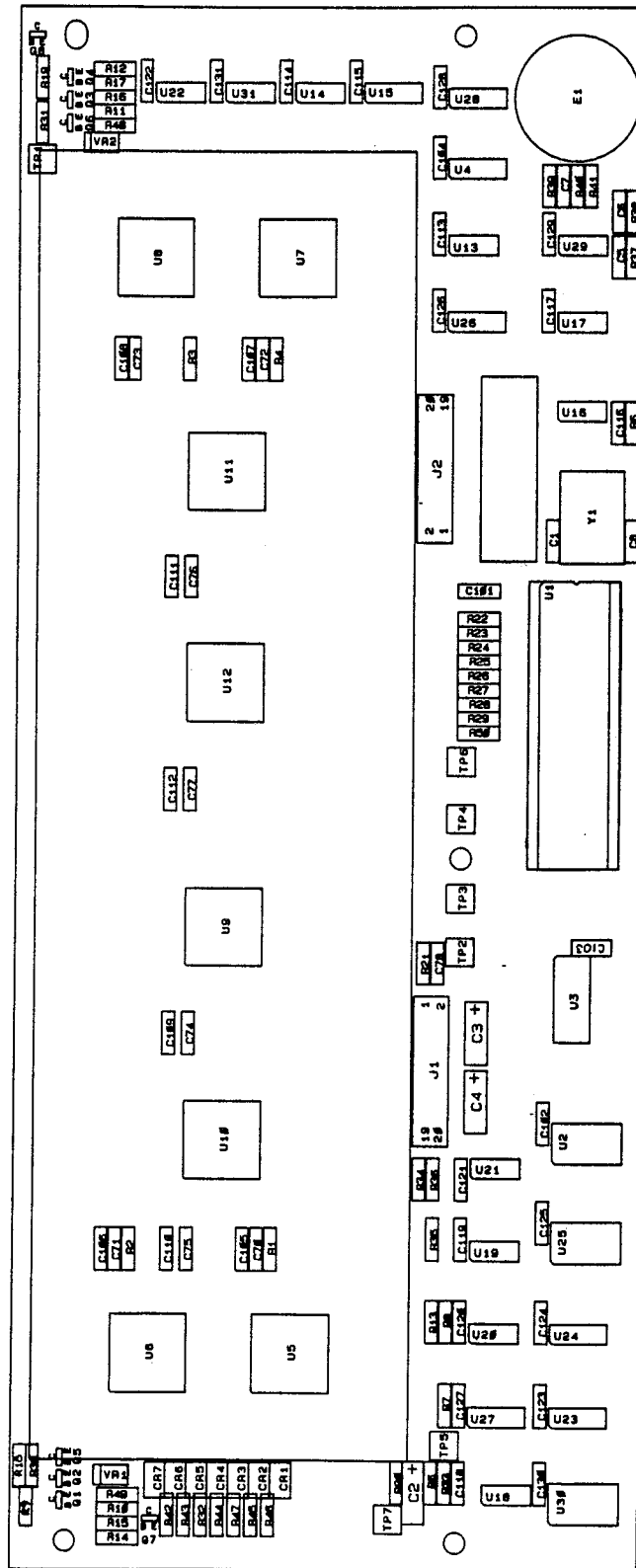

9100A-1602

Figure 5-3. A2 Display Interface PCA

5/List of Replaceable Parts

Table 5-5. A4 Video Controller PCA
(See Figure 5-4.)

REFERENCE DESIGNATOR	NUMERICS	DESCRIPTION	FLUKE STOCK	MFRS SPLY	MANUFACTURERS PART NUMBER	TOT QTY	R S	O T
-A>	----	S-----	--NO--	--CODE--	--OR GENERIC TYPE----	----	-Q	-E-
C	1, 101-131	CAP, CER, 0.01UF, +-10%, 50V, X7R, 1206	747261	72982	GRM42-6X7R103K50VPB	32		
C	2, 8	CAP, CER, 0.1UF, +-10%, 25V, X7R, 1206	747287	72982	GRM42-6X7R104K25VPB	2		
C	3, 7	CAP, TA, 10UF, +-20%, 25V	772491	56289	195D-106X0025Y2B	2	1	
C	4- 6	CAP, CER, 33PF, +-10%, 50V, COG, 1206	769240	72982	GRM42-6COG330K50VPB	3		
C	9, 10	CAP, CER, 120PF, +-10%, 50V, COG, 1206	740589	72982	GRM42-6COG121K50VPB	2		
H	1	SCREW, THD CUT, PHP, S. STL, 4-24X3/8	183574		COMMERCIAL	2		
J	1	CONN, DIN41612, TYPE R, RT ANG, 64 SKCT	782102	00779	531796-2	1		
J	2	CONN, D-SUB, FWB, RT ANG, 9 SKCT	782789	00779	205866-1	1		
Q	1	TRANSISTOR, SI, NPN, SMALL SIGNAL, SOT23	742676	01537	MMBT3904T1	1	1	
Q	2	TRANSISTOR, SI, PNP, SMALL SIGNAL, SOT23	742684	01537	MMBT3906T1	1	1	
R	1- 5, 14,	RES, CHIP, CERM, 330, +-5%, 0.125W, 1206	746370	09969	CRCW1206331JB02	7		
R	15		746370					
R	6, 13	RES, CHIP, CERM, 510, +-5%, 0.125W, 1206	746388	09969	CRCW1206511JB02	2		
R	7- 11	RES, CHIP, CERM, 158, +-1%, 0.125W, 1206	769828	09969	CRCW12061580FB02	5		
R	12	RES, CHIP, CERM, 1K, +-5%, 0.125W, 1206	745992	09969	CRCW1206102JB02	1		
R	16	RES, CHIP, CERM, 470, +-5%, 0.125W, 1206	740506	09969	CRCW1206471JB02	1		
R	17	RES, CHIP, CERM, 47, +-5%, 0.125W, 1206	746263	09969	CRCW1206470JB02	1		
R	18	RES, CHIP, CERM, 220, +-5%, 0.125W, 1206	746347	09969	CRCW1206221JB02	1		
R	19	RES, CHIP, CERM, 2.4K, +-5%, 0.125W, 1206	746495	09969	CRCW1206242JB02	1		
R	20	RES, CHIP, CERM, 1.6K, +-5%, 0.125W, 1206	746446	09969	CRCW1206162JB02	1		
R	21	RES, CHIP, CERM, 5.1K, +-5%, 0.125W, 1206	746560	09969	CRCW1206512JB02	1		
R	22, 23	RES, CHIP, CERM, 22, +-5%, 0.125W, 1206	746230	09969	CRCW1206220JB02	2		
R	24, 25	RES, CHIP, CERM, 10K, +-5%, 0.125W, 1206	746610	09969	CRCW1206103JB02	2		
TP	1- 10	TERM, UNINSUL, WIRE FORM, TEST POINT	781237	23634	TP10201	10		
U	1	* IC, NMOS, ADV VIDEO DISPLAY CNTRLR, PLCC	742734	18324	SCN2674BC4A44T	1	1	
U	2	* IC, BIPOLAR, CLR/MONO ATTRI CNTRLR, PLCC	742742	18324	SCB2675BCSA44T	1	1	
U	3, 4	* IC, 2K X 8 STATIC RAM, 120NSEC, SOIC	742783	8V413	CXK5816M-12L	2	1	
U	5	* PROGRAMMED 27128-150 V1.0	818195	89536	818195	1	1	
U	6- 8	* IC, FTTL, QUAD 2-1 LINE MUX, SOIC	773028	18324	74F157ADT	3	1	
U	9, 10	* IC, LSTTL, OCTL LINE DRVR, SOIC	742122	18324	N74LS244DT	2	1	
U	11, 12	* IC, LSTTL, OCTL D TRNSPRNT LATCHES, SOIC	742726	18324	N74LS373DT	2	1	
U	13	* IC, LSTTL, OCTAL D F/F, +EDG TRG, SOIC	741975	18324	N74LS374DT	1	1	
U	14	* IC, LSTTL, QUAD D F/F, +EDG TRG, SOIC	742619	18324	N74LS175DT	1	1	
U	15	* IC, STTL, QUAD D F/F, +EDG TRG, SOIC	742700	18324	N74S175DT	1	1	
U	16- 19	* IC, LSTTL, QUAD 2 INPUT NAND GATE, SOIC	741033	18324	N74LS00DT	4	1	
U	20, 21	* IC, LSTTL, TRIPLE 3-INPUT AND GATE, SOIC	741264	18324	N74LS10D	2	1	
U	22	* IC, LSTTL, HEX INVERTER, SOIC	741017	18324	N74LS04DT	1	1	
U	23	* IC, LSTTL, SINGLE 8-INP. NAND GATE, SOIC	742510	18324	N74LS30D	1	1	
U	24	* IC, ALSTTL, DUAL JK F/F, -EDG TRG, SOIC	807578	12040	DM74ALS112AM	1	1	
U	25	* IC, STTL, QUAD 2 INPUT +OR GATE, SOIC	742692	18324	74S86D	1	1	
U	26	* IC, LSTTL, QUAD 2 INPUT AND GATE, SOIC	740860	18324	N74LS08DT	1	1	
U	27	* IC, LSTTL, OCTAL BUFFER INVERTED, SOIC	742627	18324	N74LS240DT	1	1	
U	28	* ISOLATOR, OPTO, DUAL, DTL/TTL COMPATABLE	418285	28480	HCPL-2630	1	1	
U	29- 31	* ISOLATOR, 20 MHZ OPTOCOUPLER	742817	28480	HCPL-2400	3	1	
XU	5	SOCKET, IC, 28 PIN	448217	91506	328-AG39D	1		
XY	1	SPACER, DIP SOCKET, 14 PIN, PLASTIC	441865	32559	814-060	1		
XZ	1, 2	SOCKET, IC, 16 PIN	276535	91506	316-AG39D	2		
Y	1	OSCILLATOR, 31.9399 MHZ, TTL CLOCK	800029	01537	K1100AM	1		

An * in 'S' column indicates a static-sensitive part.

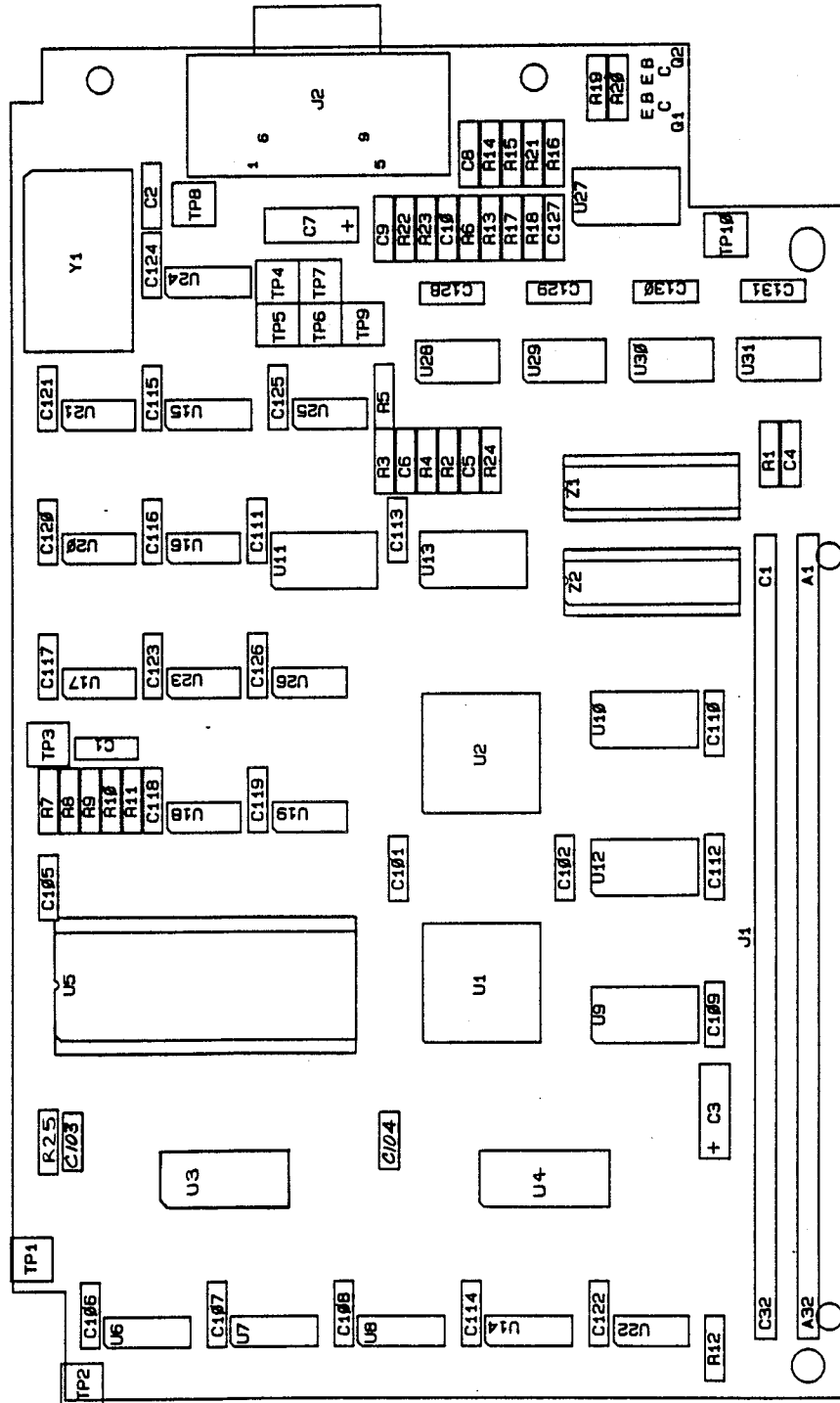

9100A-1604

Figure 5-4. A4 Video Controller PCA

5/List of Replaceable Parts

Table 5-6. A5 Probe Assembly
(See Figure 5-5.)

REFERENCE DESIGNATOR	FLUKE STOCK	MFRS SPLY	MANUFACTURERS PART NUMBER -OR GENERIC TYPE-	TOT QTY-	R S	N O T E
-A>-NUMERICS-->	S-----	DESCRIPTION-----	--NO--	--CODE--	--OR GENERIC TYPE----	QTY-- -Q -E-
C 1		CAP, CER, 27PF, +-10%, 50V, COG, 1206	800508	72982	GRM426COG270K50VPB	1
C 2, 5		CAP, CER, 1000PF, +-10%, 50V, COG, 1206	747378	72982	GRM426COG102K50VPB	2
C 3, 4		CAP, CER, 0.22UF, +80-20%, 50V, Y5V, 1206	740597	72982	GRM426Y5V224250VPB	2
C 6		CAP, CER, 0.22UF, +80-20%, 50V, Y5V, 1206	740597	72982	GRM426Y5V224250VPB	1
CR 1- 4		DIODE, SI, BV=75.0V, IO=100MA, MLF	742064	73445	BAS32	4 1
CR 5		DIODE, SI, BV=75.0V, IO=100MA, MLF	742064	73445	BAS32	1 1
L 1- 3		LAMP, SUB-MIN, 5V, 20MA	836239	S3774	0L-3043AS15	3 5
MP 1		CONNECTOR, GROUND CLIP, FINISHED	788026	89536	788026	1 1
MP 2		COVER, PROBE	773309	89536	773309	1
MP 3		KEYTOP	773333	89536	773333	1
MP 4		BODY, PROBE	773317	89536	773317	1
MP 5		DECAL, PROBE CONNECTOR	773929	89536	773929	1
Q 1, 2		TRANSISTOR, SI, PNP, SMALL SIGNAL, SOT23	742023	73445	BCX17TRL	2 1
Q 3, 4		TRANSISTOR, SI, NPN, SMALL SIGNAL, SOT23	742031	73445	BCX19TRL	2 1
R 1		RES, CHIP, CERM, 220, +-5%, 0.125W, 1206	746347	09969	CRCW1206221JB02	1
R 2		RES, CHIP, CERM, 100K, +-1%, 0.125W, 1206	769802	09969	CRCW12061003FB02	1 1
R 3, 8, 10		RES, CHIP, CERM, 200, +-5%, 0.125W, 1206	746339	09969	CRCW1206201JB02	3
R 4		RES, CHIP, CERM, 330, +-5%, 0.125W, 1206	746370	09969	CRCW1206331JB02	1
R 5, 7		RES, CHIP, CERM, 470, +-5%, 0.125W, 1206	740506	09969	CRCW1206471JB02	2
R 6		RES, CHIP, CERM, 470, +-5%, 0.125W, 1206	740506	09969	CRCW1206471JB02	1
R 9		RES, CHIP, CERM, 205K, +-1%, 0.125W, 1206	769836	09969	CRCW12062053FB02	1 1
R 11- 13		RES, CHIP, CERM, 1K, +-5%, 0.125W, 1206	745992	09969	CRCW1206102JB02	3
S 1		SWITCH, PUSHBUTTON, SPST, MOMENTARY	782656	5N615	B3F-1022	1 3
U 1		* IC, FTTL, HEX INVERT W/SCHMT TRIG, SOIC	742825	18324	N74F14D	1 1
W 1		WIRE, TEF, E, 28AWG, STRN, BLU	558320	89536	558320	1
W 2		CABLE ASSY, PROBE	783951	89536	783951	1

An * in 'S' column indicates a static-sensitive part.



CKT 1

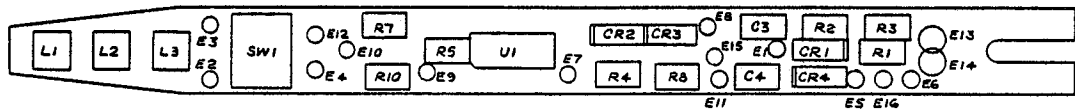

CKT 2

9100A-1605

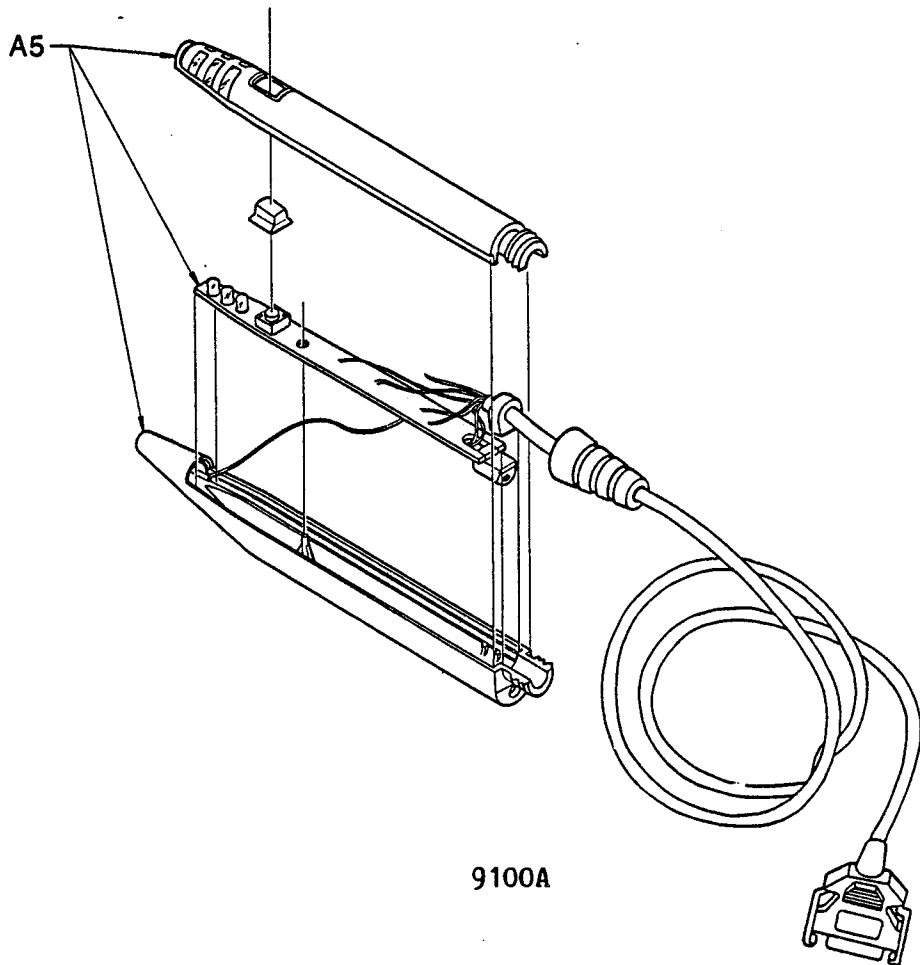

9100A

Figure 5-5. A5 Probe PCA

5/List of Replaceable Parts

Table 5-7. A6 Clock Module PCA
(See Figure 5-6.)

REFERENCE DESIGNATOR		FLUKE STOCK	MFRS SPLY	MANUFACTURERS PART NUMBER -OR GENERIC TYPE-	TOT QTY-	R S	N O T E
-A>-NUMERICS-->	S-----DESCRIPTION-----	-NO--	-CODE-			-Q	-E-
C 1- 4	CAP, CER, 8.2PF, +-10%, 50V, COG, 1206	747303	72982	GRM426COG8R2K50VPB	4		
C 5- 12, 14	CAP, CER, 0.01UF, +-10%, 50V, X7R, 1206	747261	72982	GRM426X7R103K50VPB	9		
C 13	CAP, TA, 10UF, +-20%, 25V	772491	56289	195D106X0025Y2B	1		
CR 1- 4	DIODE, SI, BV=70.0V, IO=50MA, DUAL, SOT23	742320	73445	BAV99	4		
F 1	FUSE, 1/4X1-1/4, FAST, 0.25A, 250V	109314	71400	AGC1-4	1	5	
F 1	FUSE, 5X20MM, FAST, 0.25A, 250V	543504	71400	GMA1-4	1	5	
J 1- 5	PIN, SINGLE, PWB, 0.058 DIA	233411	00779	60599-3	5		
J 6	HEADER, 2 ROW, 0.100CTR, RT ANG, 16 PIN	417030	00779	87230-8	1		
MP 1	FUSE CAP, 1/4 X 1-1/4	460238	61935	031.1666	1		
MP 1	FUSE CAP, 5 X 20 MM	461020	61935	031.1663	1		
R 1- 8	RES, CHIP, CERM, 22K, +-5%, 0.125W, 1206	746651	09969	CRCW1206273JB02	8		
R 9- 12	RES, CHIP, CERM, 11K, +-5%, 0.125W, 1206	769752	09969	CRCW1206113JB02	4		
R 13, 24- 27	RES, CHIP, CERM, 100, +-5%, 0.125W, 1206	746297	09969	CRCW1206101JB02	5	1	
R 14	RES, CHIP, CERM, 16K, +-5%, 0.125W, 1206	769745	09969	CRCW1206163JB02	1		
R 15- 22	RES, CHIP, CERM, 330, +-5%, 0.125W, 1206	746370	09969	CRCW1206331JB02	8		
R 23	RES, CHIP, CERM, 10K, +-5%, 0.125W, 1206	746610	09969	CRCW1206103JB02	1		
U 1, 2	* IC, COMPRTR, DUAL, HI-SPEED, 16 PIN DIP	782219	7J696	AM687ADL	2	1	
XF 1	HLDR PART, FUSE, BODY, PWB MT	602763	61935	FAU031.3573	1		
XU 1, 2	SOCKET, IC, 16 PIN	276535	91506	316-AG39D	2		

An * in 'S' column indicates a static-sensitive part.

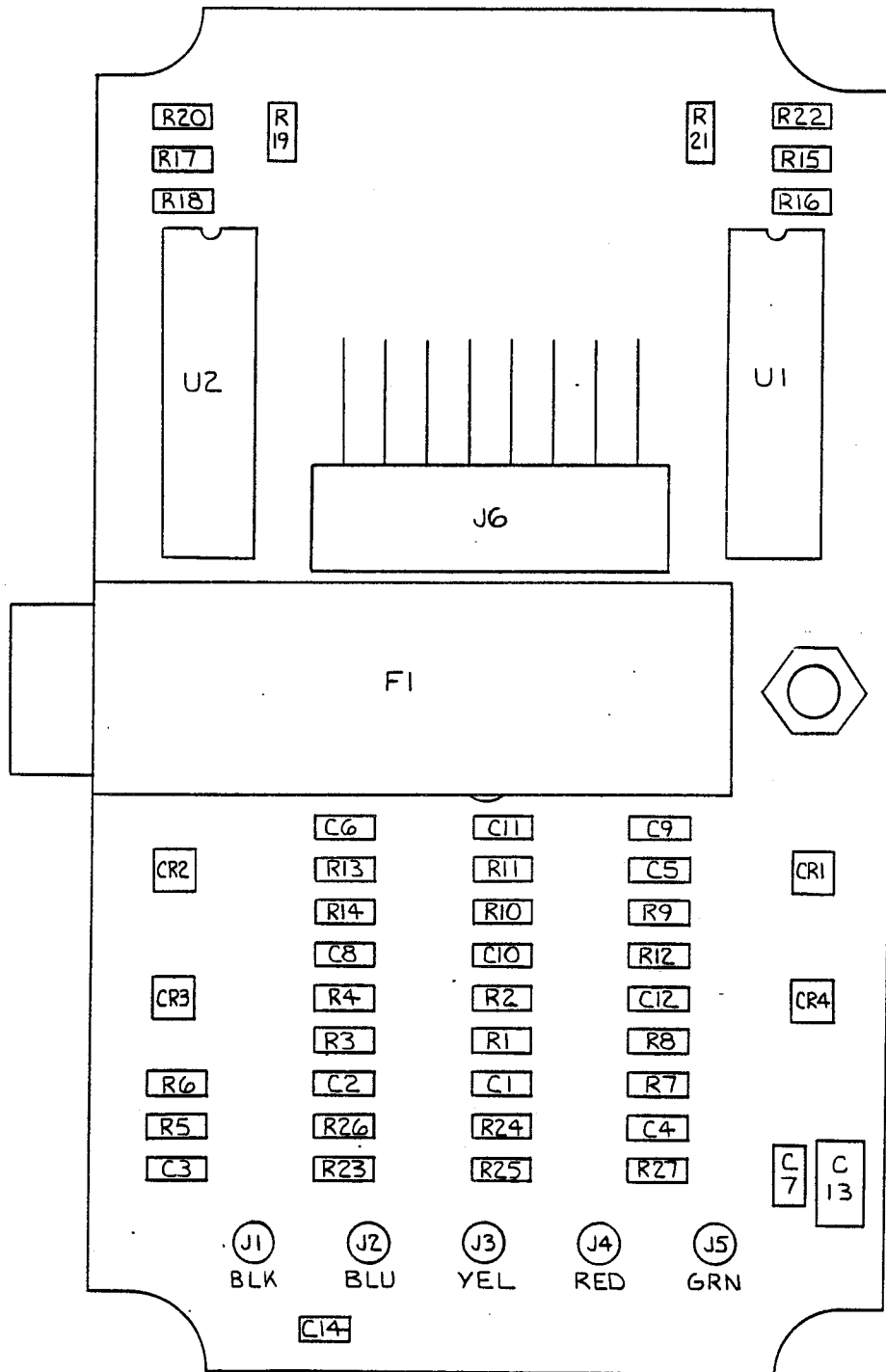

9100A-1606

Figure 5-6. A6 Clock Module PCA

5/List of Replaceable Parts

Table 5-8. A7 I/O Module Main PCA
(See Figure 5-7.)

REFERENCE DESIGNATOR	FLUKE STOCK	MFRS SPLY	MANUFACTURERS PART NUMBER	TOT QTY	R S T	N O
-A>-NUMERICS--> S-----DESCRIPTION-----	--NO--	-CODE-	-OR GENERIC TYPE-----	QTY-	-Q-	-E-
C 1, 2, 9-	772491	56289	195D106X0025Y2B	27		
C 24, 27, 37,	772491					
C 42- 44, 61,	772491					
C 62, 67, 68	772491					
C 3- 7, 28-	747261	72982	GRM426X7R103K50VPB	31		
C 36, 38, 39,	747261					
C 46- 60	747261					
C 45	747287	72982	GRM426X7R104K25VPB	1		
CR 1- 4, 7,	742320	73445	BAV99	85	5	
CR 100-179	742320					
CR 5, 6	742064	73445	BAS32	2	1	
CR 8	782573	61752	10JQ030TRRM	1	1	
E 1- 5	233411	00779	60599-3	5		
F 1	109272	75915	313/1.25	1	5	
F 1	808055	61935	034.3117	1	5	
H 1	178533		COMMERCIAL	1		
J 1	782748	00779	1-87320-9	1		
J 2, 3	783795	00779	1-86418-0	2		
MP 1	104448	89536	104448	1		
P 1	783803	22526	65598-106	1		
Q 1, 2	742684	01537	MMBT3906T1	2	1	
R 1, 2	746297	51406	RX39110G101JBA	2		
R 3, 5, 6,	769794	09969	CRCW12061002FB02	4		
R 10	769794					
R 4, 9	769851	09969	CRCW12064222FB02	2		
R 7	811463	09969	CRCW12067501FB02	1		
R 8	811455	09969	CRCW12068250FB02	1		
R 13, 14	746602	09969	CRCW1206912JB02	2		
R 15, 17	769299	09969	CRCW1206433JB02	2		
R 16, 18	769257	09969	CRCW1206911JB02	2		
R 19, 20, 23-	740522	09969	CRCW1206472JB02	10		
R 30	740522					
R 21, 22, 31,	745992	09969	CRCW1206102JB02	7		
R 33, 34, 39,	745992					
R 40	745992					
R 32	769752	09969	CRCW1206113JB02	1		
TP 1- 8	781237	26364	TF10201	8		
U 1	634113	01537	RASCO-3	1		
U 2	742569	18324	LM324D	1	1	
U 3, 5	740860	18324	N74LS08DT	2	1	
U 4	742585	18324	N74HCT040	1	1	
U 6	740969	18324	N74LS138DT	1	1	
U 7	742726	18324	N74LS373DT	1	1	
U 8	742577	18324	N74HCT245DT	1	1	
U 9	801274	04713	MC10H125P	1	1	
U 10	740878	18324	N74LS32D	1	1	
U 11, 12	741256	18324	N74LS112DT	2	1	
U 13, 16, 17	742593	18324	N74HCT244DT	3	2	
U 14	740928	18324	N74LS273DT	1	1	
U 15	742510	18324	N74LS30D	1	1	
U 18	780767	18324	74HCT153DT	1	1	
U 100,110,120,	760785	89536	760785	5	1	
U 130,140	760785					
U 101,103,111,	800185	59640	VP0204N6	10	2	
U 113,121,123,	800185					
U 131,133,141,	800185					
U 143	800185					
U 102,104,112,	782557	59640	VN0104N6	10	2	
U 114,122,124,	782557					
U 132,134,142,	782557					
U 144	782557					
U 105,106,115,	801043	18324	74HCT2440T	10	1	
U 116,125,126,	801043					
U 135,136,145,	801043					
U 146	801043					
XF 1	602763	61935	FAU031.3573	1		
XY 1	441865	32559	814-060	1		
Z 1,100,110,	780460	09969	MDP1603101J	6	1	
Z 120,130,140	780460					

An * in 'S' column indicates a static-sensitive part.

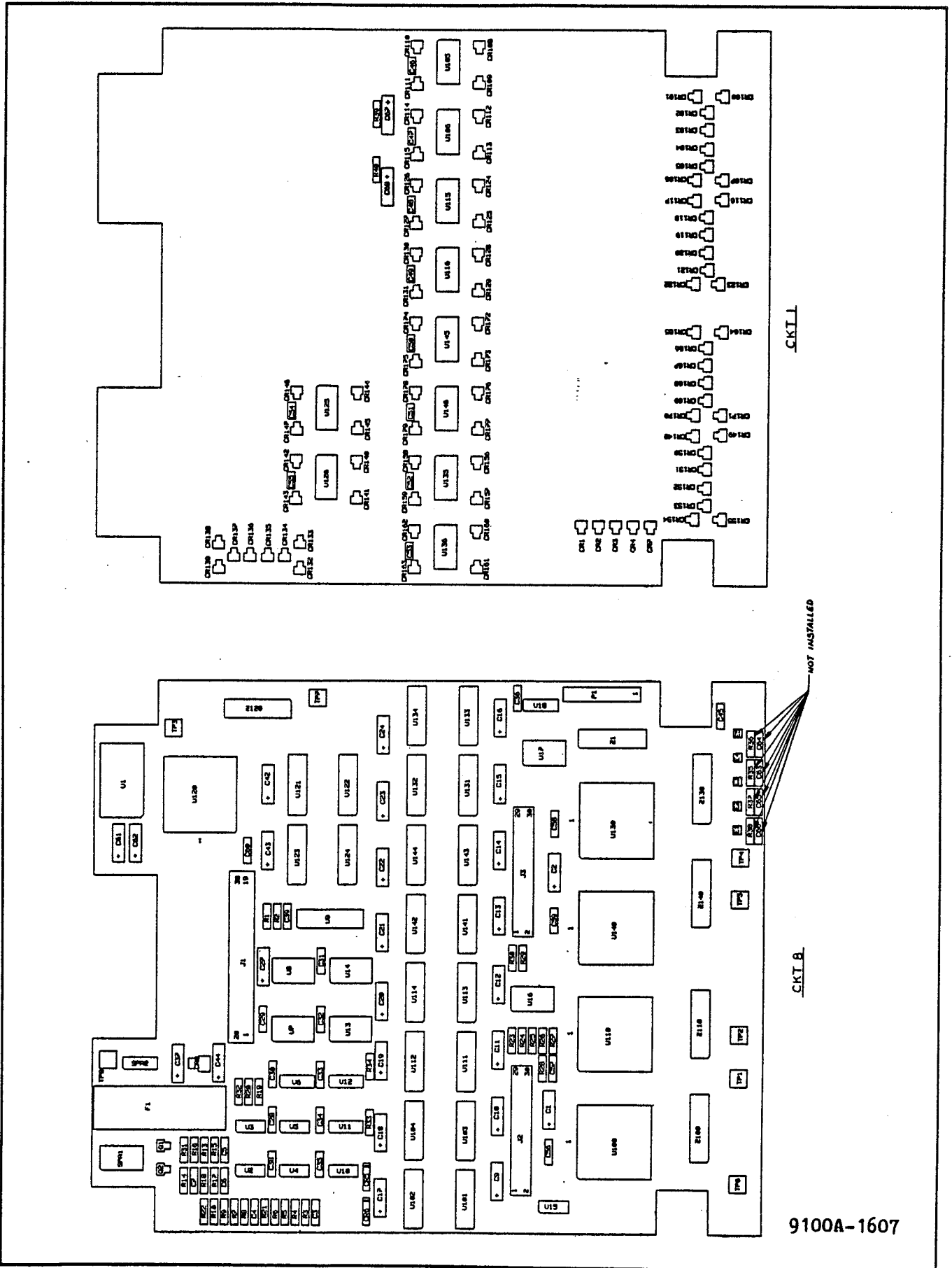

Figure 5-7. A7 I/O Module (Main) PCA

5/List of Replaceable Parts

Table 5-9. A8 I/O Module (Top) PCA
(See Figure 5-8.)

REFERENCE DESIGNATOR			FLUKE STOCK	MFRS SPLY	MANUFACTURERS PART NUMBER	TOT	R	N
-A>-NUMERICS	->	S-----DESCRIPTION-----	--NO--	-CODE-	-OR GENERIC TYPE-----	QTY-	-Q-	-E-
C	1- 4	CAP, AL, 4700UF, +-20%, 16V, SOLV PROOF	800904	62643	SME16T472M18X40LL	4	1	
CR	1- 4	* DIODE, SI, 100 PIV, 1.0 AMP	343491	01295	1N4002	4	1	
H	1	SCREW, MACH, PHP SEMS, STL, 6-32X1/4	178533		COMMERCIAL	2		
H	2	SCREW, MACH, PHP SEMS, STL, 4-40X3/16	732750		COMMERCIAL	4		
J	1, 4	HEADER, 2 ROW, 0.100CTR, 30 PIN	801233	22526	68464-630	2		
J	2, 3	CONN, RECT, PWB, REC, 33 POS	800672	50541	KA33/127BPF021TAHF6	2		
MP	1	COVER, SHIELD I/O MODULE	768036	89536	768036	1		
MP	2	SPACER, SWAGED, RND, BRASS, 6-32X0.590	811224	9W423	9538B-B-0632	5		
MP	3	SPACER, SWAGED, RND, BRASS, 6-32X0.250	446351	9W423	9533B-B-0440	2		
P	1- 4	GUIDE SOCKET	805648	89536	805648	4		

An * in 'S' column indicates a static-sensitive part.

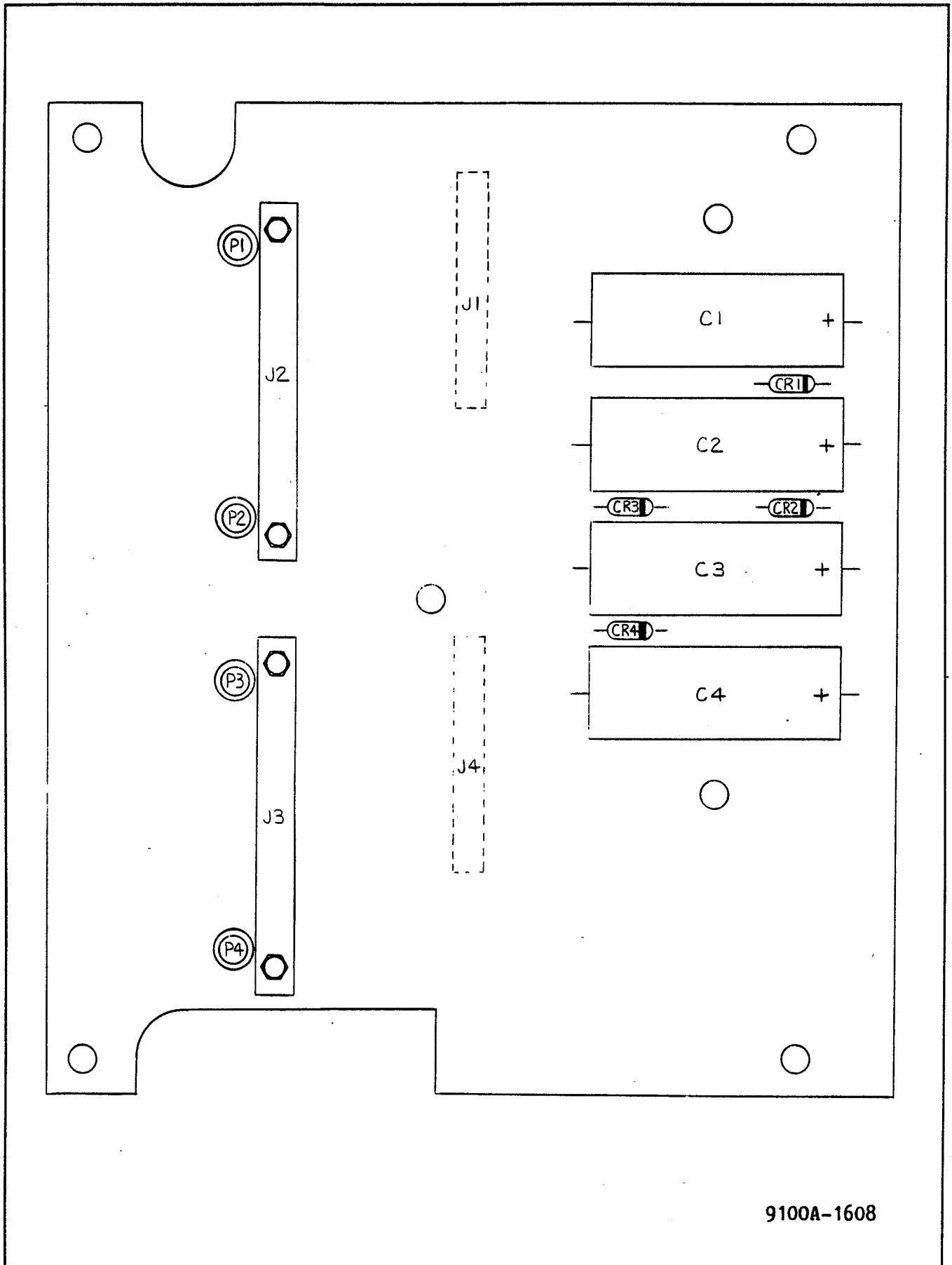

9100A-1608

Figure 5-8. A8 I/O Module (Top) PCA

5/List of Replaceable Parts

Table 5-10. A9 Probe I/O Interface PCA
(See Figure 5-9.)

REFERENCE DESIGNATOR	FLUKE STOCK	MFRS SPLY	MANUFACTURERS PART NUMBER	TOT QTY	R S T	N O T
-A>-NUMERICS----->	-----DESCRIPTION-----	--NO--	-CODE- -OR GENERIC TYPE-----	QTY-	-Q	-E-
C 1, 3, 4,	CAP, CER, 0.1UF, +-10%, 25V, X7R, 1206	747287	72982 GRM42-6X7R104K25VBP	23		
C 8- 11, 16,		747287				
C 17, 19, 21,		747287				
C 23, 25- 33,		747287				
C 39, 40		747287				
C 2	CAP, VAR, 6-50PF, 50V, CER	714618	72982 T2032500YR-174	1		
C 5, 7, 20,	CAP, TA, 10UF, +-20%, 25V	772491	56289 195D106X0025Y2B	6		
C 22, 24, 35		772491				
C 6, 14, 18	CAP, TA, 1.5UF, +-20%, 50V	780478	56289 195D155X0050X2B	3		
C 12	CAP, CER, 180PF, +-10%, 50V, COG, 1206	769778	72982 GRM42-6COG181K50VBP	1		
C 13	CAP, CER, 33PF, +-10%, 50V, COG, 1206	769240	72982 GRM42-6COG330K50VBP	1		
C 15	CAP, CER, 0.022UF, +-10%, 50V, X7R, 1206	747279	72982 GRM42-6X7R223K50VBP	1		
C 34	CAP, CER, 1500PF, +-10%, 50V, COG, 1206	781203	72982 GRM42-6COG152K50VBP	1		
C 36	CAP, CER, 470PF, +-10%, 50V, COG, 1206	747360	72982 GRM42-6COG471K50VBP	1		
C 37, 38	CAP, CER, 0.01UF, +-10%, 50V, X7R, 1206	747261	72982 GRM42-6X7R103K50VBP	2		
C 41, 42	CAP, TA, 47UF, +-20%, 20V	348516	56289 199D476X0020EA4	2		
CR 1- 6, 8,	DIODE, SI, BV=75.0V, IO=100MA, MLF	742064	73445 BAS32	8	1	
CR 11		742064				
CR 7, 9, 10	DIODE, SI, BV=70.0V, IO=50MA, DUAL, SOT23	742320	73445 BAV99	3	2	
CR 12	DIODE, SI, SCHOTTKY, 30V, 1.1A, SOT89	782573	61752 10JQ030TRRM	1	1	
F 1	FUSE, 1/4X1-1/4, FAST, 0.25A, 250V	109314	71400 AGC1-4	1	5	
F 1	FUSE, 5X20MM, FAST, 0.25A, 250V	543504	71400 GMA1-4	1	5	
J 1	CONN, D-SUB, PWB, RT ANG, 15 SCKT	782169	00779 747845-4	1		
J 2	CONN, DIN41612, TYPE R, 64 PIN	782094	00779 532523-2	1		
J 3	CONN, D-SUB, PWB, RT ANG, 15 PIN	782151	00779 747841-4	1		
J 4	HEADER, 1 ROW, 0.100CTR, RT ANG, 6 PIN	714154	22526 65521-106	1		
J 5	JACK, PWB, RT ANG, 4 POS	782086	00779 520949-2	1		
J 6, 7	HEADER, 2 ROW, 0.100 CTR, 40 PIN	603670	00779 2-87227-0	2		
MP 1	FUSE CAP 1/4X1-1/4	460238	61935 031.1666	1		
MP 1	FUSE CAP 5 X 20 MM	461020	61935 031.1663	1		
Q 1	* TRANSISTOR, SI, N-JFET, DUAL, TO-78	478370	13327 FD1838	1	1	
Q 2, 6, 7,	TRANSISTOR, SI, PNP, SMALL SIGNAL, SOT23	742023	73445 BCX17TRL	4	1	
Q 9		742023				
Q 3, 4, 5,	TRANSISTOR, SI, NPN, SMALL SIGNAL, SOT23	742031	73445 BCX19TRL	4	1	
Q 8		742031				
Q 10, 11	* TRANSISTOR, SI, BV= 45V, 30W, TO-220	325761	09214 D44C5	2	1	
R 1	RES, CHIP, CERM, 33, +-5%, 0.125W, 1206	746248	09969 CRCW1206330JB02	1		
R 2	RES, CHIP, CERM, 3.6K, +-5%, 0.125W, 1206	746537	09969 CRCW1206362JB02	1		
R 3- 6, 48,	RES, CHIP, CERM, 330, +-5%, 0.125W, 1206	746370	09969 CRCW1206330JB02	6		
R 49		746370				
R 7	RES, CHIP, CERM, 150, +-5%, 0.125W, 1206	746313	09969 CRCW1206151JB02	1		
R 8	RES, CHIP, CERM, 15K, +-1%, 0.125W, 1206	769810	09969 CRCW12061502FB02	1		
R 9	RES, CHIP, CERM, 22, +-5%, 0.125W, 1206	746230	09969 CRCW1206220JB02	1		
R 10- 12, 14,	RES, CHIP, CERM, 470, +-5%, 0.125W, 1206	740506	09969 CRCW1206471JB02	6		
R 21, 28		740506				
R 13, 15	RES, CHIP, CERM, 200, +-5%, 0.125W, 1206	746339	09969 CRCW1206201JB02	2		
R 16, 46, 51,	RES, CHIP, CERM, 511, +-1%, 0.125W, 1206	769869	09969 CRCW12065110FB02	4		
R 59		769869				
R 17, 20, 26,	RES, CHIP, CERM, 1K, +-5%, 0.125W, 1206	745992	09969 CRCW1206102JB02	8		
R 31, 36, 41,		745992				
R 54, 78		745992				
R 18, 22, 23,	RES, CHIP, CERM, 4.7K, +-5%, 0.125W, 1206	740522	09969 CRCW1206472JB02	23		
R 27, 32- 34,		740522				
R 37, 38, 42,		740522				
R 52, 53, 55,		740522				
R 56, 58, 61-		740522				
R 63, 67, 72,		740522				
R 80, 82, 86		740522				
R 19, 35, 84,	RES, CHIP, CERM, 47K, +-5%, 0.125W, 1206	746685	09969 CRCW1206473JB02	4		
R 85		746685				
R 24, 29, 30	RES, CHIP, CERM, 9.1K, +-5%, 0.125W, 1206	746602	09969 CRCW1206912JB02	3		
R 25	RES, CHIP, CERM, 3.9K, +-5%, 0.125W, 1206	746545	09969 CRCW1206392JB02	1		
R 39	RES, CHIP, CERM, 470K, +-5%, 0.125W, 1206	746792	09969 CRCW1206471JB02	1		
R 40, 43, 45,	RES, CHIP, CERM, 100, +-5%, 0.125W, 1206	746297	09969 CRCW1206101JB02	6		
R 47, 79, 81		746297				
R 44	RES, CHIP, CERM, 300K, +-5%, 0.125W, 1206	746768	09969 CRCW1206301JB02	1		
R 50, 57	RES, CHIP, CERM, 1.15K, +-1%, 0.125W, 1206	780981	09969 CRCW12061151FB02	2		
R 60	RES, CHIP, CERM, 4.02K, +-1%, 0.125W, 1206	783266	09969 CRCW12064021FB02	1		
R 64	RES, CHIP, CERM, 750, +-5%, 0.125W, 1206	746404	09969 CRCW1206751JB02	1		
R 65	RES, CHIP, CERM, 39K, +-5%, 0.125W, 1206	746677	09969 CRCW1206393JB02	1		

An * in 'S' column indicates a static-sensitive part.

5/List of Replaceable Parts

Table 5-10. A9 Probe I/O Interface PCA (cont.)

REFERENCE DESIGNATOR	FLUKE STOCK	MFRS SPLY	MANUFACTURERS PART NUMBER	TOT QTY	R O S T	N -E
-A>-NUMERICS--> S	DESCRIPTION	-NO--	-OR CODE- -OR GENERIC TYPE			
R 68, 75	RES,CHIP,CERM,30.1K,+/-1%,0.125W,1206	801258	09969 CRCW12063012FB02	2		
R 69	RES,CHIP,CERM,47,+/-5%,0.125W,1206	746263	09969 CRCW1206470JB02	1		
R 70	RES,CHIP,CERM,3.4K,+/-1%,0.125W,1206	769844	09969 CRCW12063401FB02	1		
R 71, 74, 76,	RES,CHIP,CERM,10K,+/-1%,0.125W,1206	769794	09969 CRCW12061002FB02	4		
R 77		769794				
R 73	RES,CHIP,CERM,620,+/-5%,0.125W,1206	745984	09969 CRCW1206621JB02	1		
R 83	RES,CF,2.2,+/-5%,0.25W	354944	80031 CR251-4-5P2E2	1	1	
R 87	RES,CHIP,CERM,1.30K,+/-1%,0.125W,1206	780999	09969 CRCW12061301FB02	1		
R 88	RES,CHIP,CERM,243,+/-1%,0.125W,1206	810606	09969 CRCW12062430FB02	1	1	
R 90	RES,CHIP,CERM,22,+/-5%,0.125W,1206	746230	09969 CRCW1206220JB02	1		
TP 1- 7	TERM,UNINSUL,WIRE FORM,TEST POINT	781237	26364 TP-102-01	7		
U 1	ISOLATOR, 20 MHZ OPTOCOUPLER	742817	28480 HCPL-2400,OPTION100	1	1	
U 2	* IC,FTTL,QUAD 2 INPUT XOR GATE,SOIC	742171	18324 N74F86DT	1	1	
U 3	* IC,LSTTL,QUAD 2 INPUT NOR GATE,SOIC	741025	18324 N74LS02DT	1	1	
U 4, 12	* IC,FTTL,HEX INVERTER,SOIC	742148	18324 N74F04DT	2	1	
U 5	* IC,FTTL,QUAD DUAL AND GATE,SOIC	780957	18324 N74100T	1	1	
U 6	* IC,CMOS,HEX INVERTER W/SCHT TRIG,SOIC	780965	18324 N74HCT14DT	1	1	
U 7, 13	* IC,LSTTL,QUAD 2 INPUT OR GATE,SOIC	740878	18324 N74LS32D	2	1	
U 8	* IC,LSTTL,2-4 LINE DEMUX,SOIC	740951	18324 N74LS139D	1	1	
U 9	* IC,FTTL,QUAD 2-1 LINE MUX,SOIC	773028	18324 74F1S7ADT	1	1	
U 10	* IC,FTTL,DUAL D F/F,+EDG TRG,SOIC	742163	18324 74F74DT	1	1	
U 11	* IC,FTTL,QUAD 2 INPUT OR GATE,SOIC	743237	18324 N74F32DT	1	1	
U 14, 15	* IC,LSTTL,OCTL LINE DRVR,SOIC	742122	18324 N74LS244DT	2	1	
U 16	* IC,FTTL,DUAL 4-1 LINE MUX,SOIC	772806	18324 74F153D	1	1	
U 17	* IC,LSTTL,QUAD D F/F,+EDG TRG,SOIC	742619	18324 N74LS175DT	1	1	
U 18	* IC,STTL,600 GATE ARY,9100A-99100,PLCC	741546	61271 MB113T306	1	1	
U 19	* IC,STTL,600 GATE ARY,9100A-99101,PLCC	741553	61271 MB113T306	1	1	
U 20, 23	* IC,BIPOLAR,8-BIT DAL,UP-COMPATIBLE	743112	24355 AD558JN	2	1	
U 21, 22	* IC,LSTTL,8-BIT BINARY CNTR W/REG,SOIC	782243	01295 SN74LS590DR	2	1	
U 24, 37	* IC,COMPARATOR,QUAD,14 PIN,SOIC	741561	18324 LM339DT	2	1	
U 25	* IC,LSTTL,QUAD BUS,SOIC	740977	18324 N74LS125ADT	1	1	
U 26, 32, 33	* IC,LSTTL, 4 BIT UP/DOWN CNTR,SOIC	742114	18324 N74LS191DT	3	1	
U 27	* IC,LSTTL,DUAL D F/F,+EDG TRG,SOIC	740985	18324 S74LS74ADT	1	1	
U 28, 29	* IC,ECL,QUAD ECL-TTL TRANSLATOR	801274	04713 MC10H12SP	2	1	
U 30	* IC,COMPTRR,DUAL,HI-SPEED,16 PIN DIP	782219	00718 AM687ADL	1	1	
U 31	* IC,FTTL,QUAD D F/F,+EDG TRG,SOIC	801399	18324 74F175DT	1	1	
U 34	* IC,FTTL, 4 BIT UP/DOWN COUNTER	782235	07263 74F191DC	1	1	
U 35, 36, 39	* IC,LSTTL,OCTL BUS TRNSCVR W/3-ST,SOIC	781195	18324 N74LS245D	3	1	
U 38	* IC,FTTL,DUAL 4 INPUT NAND GATE,SOIC	742155	18324 N74F20DT	1	1	
U 40	* IC,VOLT REG,FIXED,+5 VOLTS,0.1 AMPS	429910	07263 UA78L05AWC	1	1	
U 41	* IC,OP AMP,QUAD,LOW POWER,SOIC	742569	18324 LM324D	1	1	
XF 1	HLD R PART,FUSE,BODY,PWB MT	602763	61935 FAU031.3573	1		

An * in 'S' column indicates a static-sensitive part.

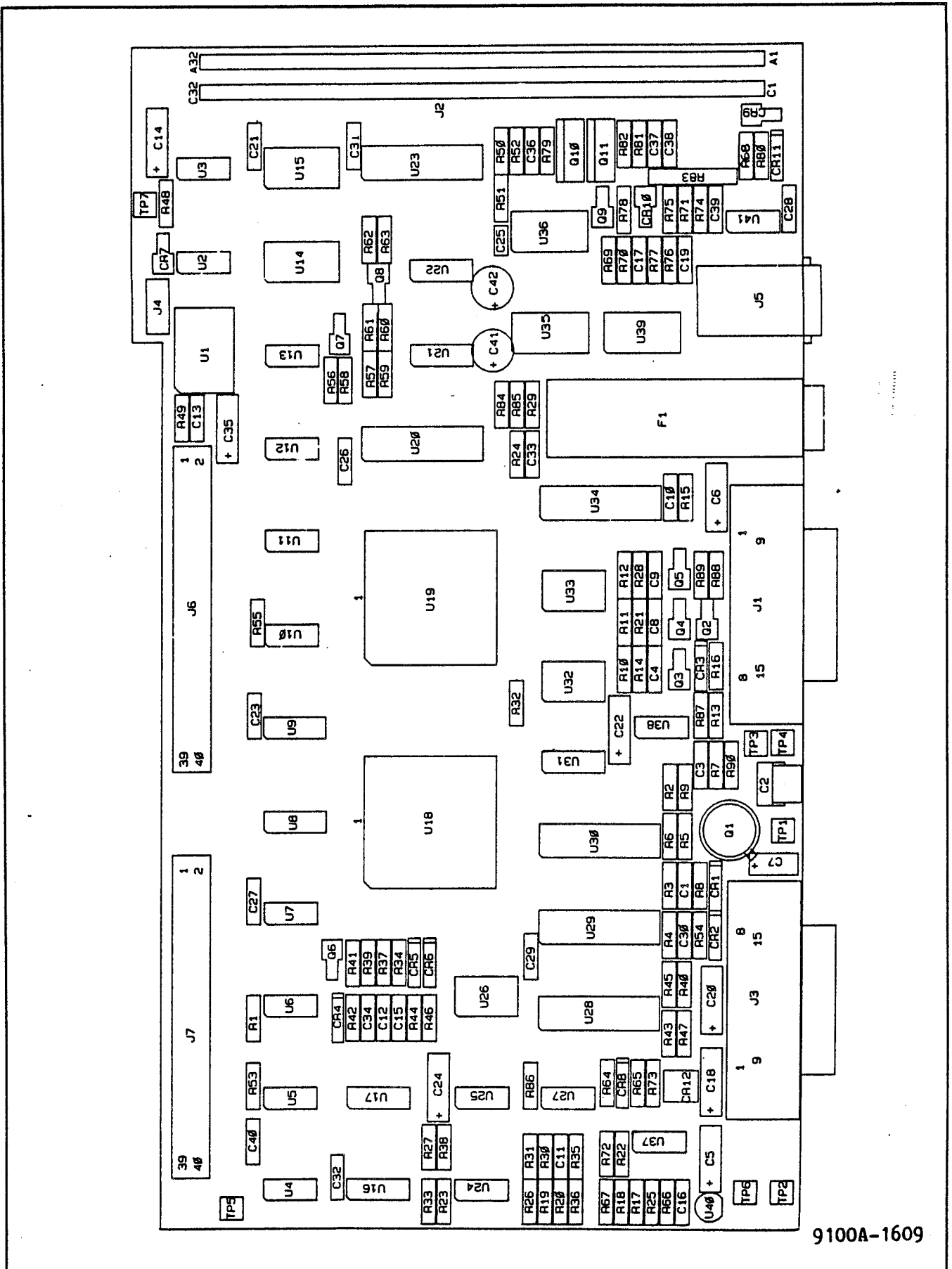

9100A-1609

Figure 5-9. A9 Probe I/O Interface PCA

5/List of Replaceable Parts

Table 5-11. A10 Multi-Function Interface PCA
(See Figure 5-10.)

REFERENCE DESIGNATOR	FLUKE STOCK	MFRS SPLY	MANUFACTURERS PART NUMBER	TOT QTY	R S T	N O
-A>-NUMERICS-----> S-----DESCRIPTION-----	--NO--	-CODE-	--OR GENERIC TYPE-----	QTY-	-Q-	-E-
B 1	782953	50120	LTC-7P	1	1	
C 1, 2	369074	80031	2222-631-10159	2	1	
C 3, 10- 21	407361	72982	8121-A100-W5R-103M	13		
CR 1	* 203323	07910	1N4448	1	1	
H 1	183574		COMMERCIAL	2		
H 2	423616		COMMERCIAL	2		
J 1	747816	00779	531796-1	1		
J 2	783464	00779	1-103311-0	1		
J 3	782201	00779	2-87227-5	1		
MP 1	768663	89536	768663	1		
Q 1	* 195974	64713	2N3906	1	1	
Q 2	* 218396	04713	2N3904	1	1	
R 1- 3, 6,	348839	80031	CR251-4-5P10K	7		
R 7, 9, 12	348839					
R 4	221986	01121	CB2265	1		
R 5	376434	80031	CR251-4-5P51K	1		
R 8, 10	441485	80031	CR251-4-5P200K	2		
RN 1, 2	769356	09969	CSC10A01221G	2		
RN 3, 4	769364	09969	CSC10A01331G	2		
RN 5	414003	80031	95081002CL	1		
TP 1- 3	781237	26364	TP10201	3		
U 2	* 742858	00718	AM5380PC	1	1	
U 3	* 818211	89536	818211	1	1	
U 9	* 604181	12040	MM58167N	1	1	
U 10	* 408732	01295	SN74LS164N	1	1	
U 11	* 799924	18324	74HCT04N	1	1	
U 12	* 741280	54590	C074HCT00	1	1	
XU 2	429282	09922	DILB40P-108	1		
XU 3	643999	51398	3852324-02	1		
XU 9	376236	91506	324-AG39D	1		
Y 1	* 501817	87516	861T32.768	1	1	

An * in 'S' column indicates a static-sensitive part.

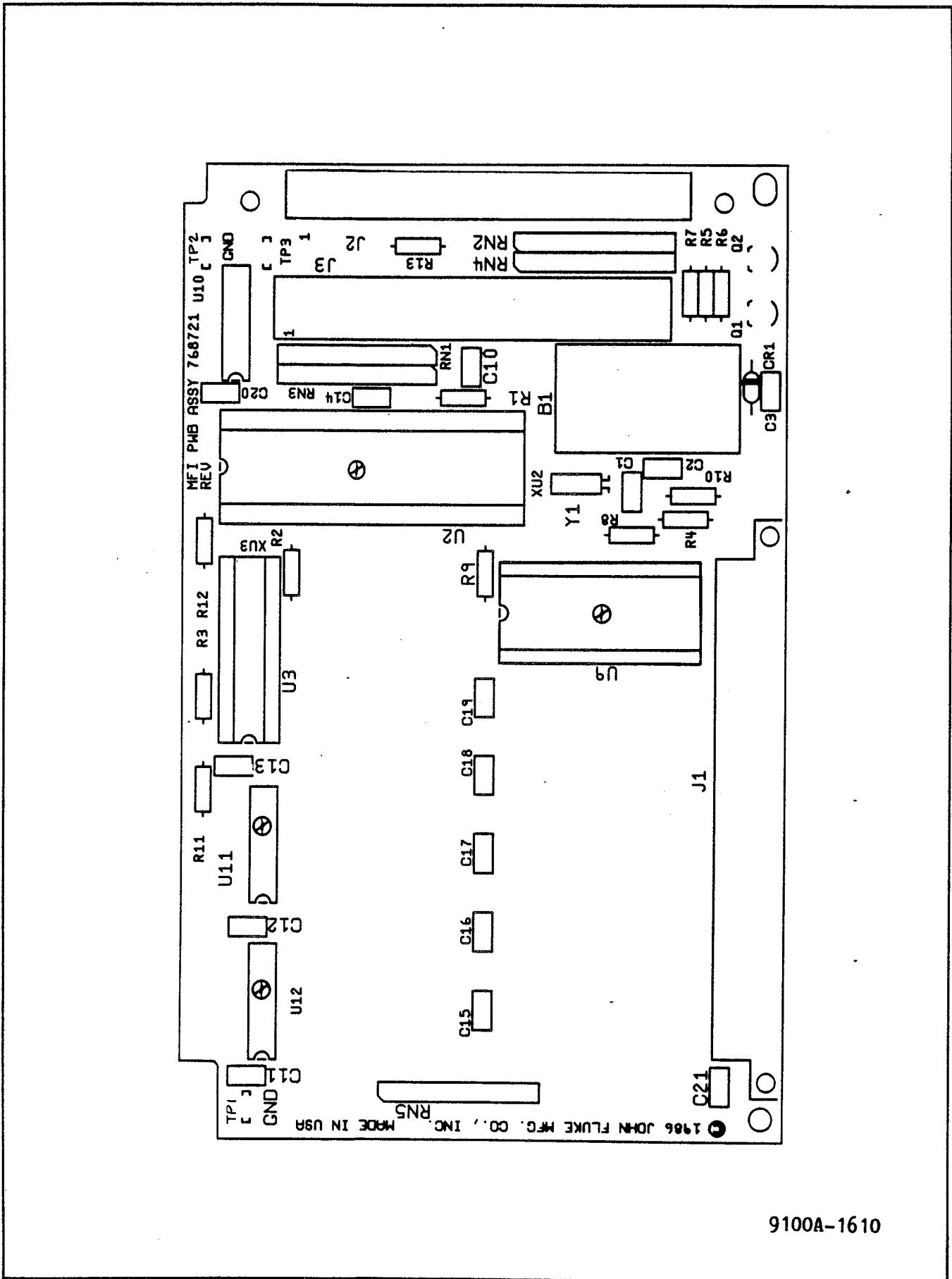

Figure 5-10. A10 Multi-Function Interface PCA

5/List of Replaceable Parts

Table 5-12. All I/O Connector PCA
(See Figure 5-11.)

REFERENCE DESIGNATOR	FLUKE STOCK	MFRS SPLY	MANUFACTURERS PART NUMBER	TOT	R	O	N
-A>-NUMERICS--> S	-----DESCRIPTION-----	--NO--	-CODE- -OR GENERIC TYPE-----	QTY-	-Q	-E-	-E-
C 1, 17	CAP,AL,1000UF,+50-20%,35V	641217	57640 SM35VB-1000	2			
C 2- 15	CAP,CER,0.01UF,+20%,100V,X7R	407361	72982 8121-A100-W5R-103M	14	1		
C 16	CAP,AL,10000UF,+20%,6.3V,SOLV PROOF	800045	62643 SME6.3T103M16X40LL	1			
CR 1, 2	* DIODE,SI,100 PIV,1.0 AMP	343491	01295 1N4002	2	1		
H 1	SCREW,MACH,PH,P,STL,6-32X0.250	152140	COMMERCIAL	2			
H 2	SCREW,THD CUT,PHP,S,STL,4-24X3/8	183574	COMMERCIAL	2			
J 1	CONN,DIN41612,TYPE R,RT ANG,64 SCRT	782102	00779 531796-2	1			
J 2- 5	CONN,D-SUB,PWB,37 SCKT	782177	00779 2-747709-0	4			
MP 1	HEAT DISSIPATOR,1.000,FOR TO-66	799965	30161 ER5758B	1			
R 1	RES,CF,10K,+5%,0.25W	348839	80031 CR251-4-5P10K	1			
R 3	RES,NW,0.47,+5%,2W	219360	23237 SPH247-5	1	1		
R 4	RES,MF,243,+0.1%,0.125W,50PPM	512228	09969 CMF55-2430-B-T2	1			
R 5	RES,MF,732,+1%,0.125W,100PPM	294884	81349 RNC60H7320F	1			
TP 1	TERM,UNINSUL,WIRE FORM,TEST POINT	781237	26364 TP102-01	1			
U 1, 2	* IC,ECL,QUAD TTL-ECL TRANSLATOR	801266	04713 MC10H124P	2	1		
U 3	* IC,LSTTL,DUAL 4 INPUT NAND GATE	393280	01295 SN74LS20N	1	1		
U 4	* IC,VOLT REG,ADJ,1.2 TO 32 V,5 AMP OUT	585497	12040 LM338K	1	1		
Z 1, 3	RES,NET,SIP,10PIN,9RES,330,+2%	769364	04713 SN74LS20N	2			
Z 2	RES,NET,SIP,10PIN,9RES,4.7K,+2%	484063	80031 95081002CL	1			

An * in 'S' column indicates a static-sensitive part.

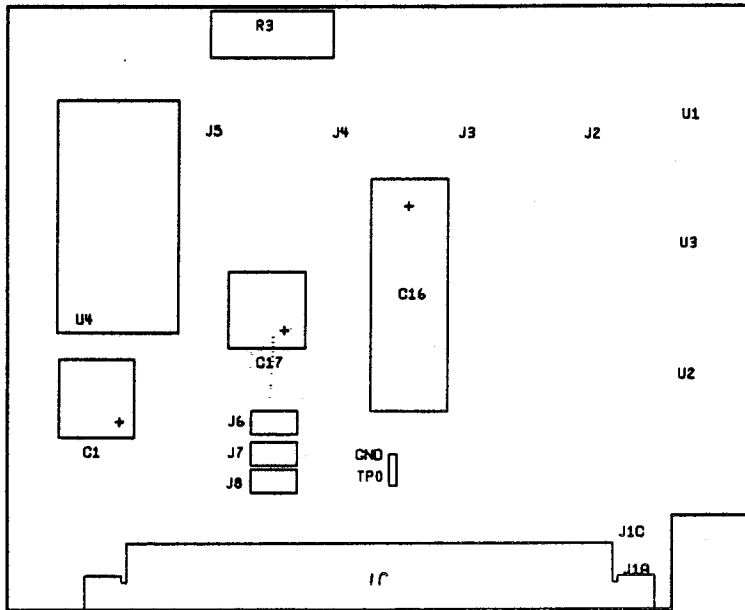

CKT 1 SIDE

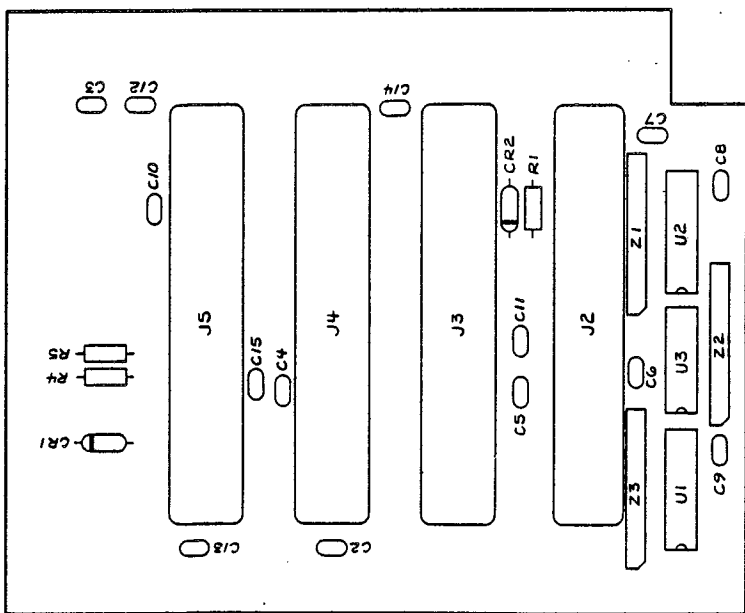

CKT 4 SIDE

9100A-1611

Figure 5-11. A11 I/O Connector PCA

5/List of Replaceable Parts

Table 5-13. A12 Half-Width Clip Modules

REFERENCE DESIGNATOR	FLUKE STOCK	MFRS SPLY	MANUFACTURERS PART NUMBER	TOT QTY	R S	O T
-A>-NUMERICS-----> S-----DESCRIPTION-----	--NO--	-CODE-	-OR GENERIC TYPE-----	QTY-	-Q-	-E-
C 1	597575	72982	RPE11025U104M50V	1		
C 2	407361	72982	8121-A100-W5R-103M	1		
H 1	800656	COMMERCIAL		4		
J 1	800680	50541	KA33/127BEMD11T	1	1	
J 2, 3		89536		2		1
MP 1		89536		1	2	1
MP 2	757500	05276	4521-0	1	2	
MP 3	773895	89536	773895	1		
MP 4	768697	89536	768697	1		
MP 5	774034	89536	774034	1		
MP 6		89536		2		1
MP 7		89536		1		1
P 1, 2	800698	88245	1781B-1	2		
S 1	782433	5N615	B3F-3122	1	1	
S 2	408559	00779	435166-2	1		
W 1		89536		1		1
W 2	801704	89536	801704	1	1	

An * in 'S' column indicates a static-sensitive part.

NOTES:

1 - Refer to the table below for appropriate part numbers for each type of Clip Module:

	MODULE								
	-14D	-14S	-16D	-16S	-18D	-20D	-20S	-24D	-24S
MP1	800052	817429	800060	817437	800078	800086	817445	800094	817478
W1	801639	801639	801647	801647	801654	801662	801662	801670	801670
J2,3	801878	801878	801886	801886	801894	801902	801902	801910	801910
MP6	-	-	-	-	773952	773952	773952	767954	767954
MP7	802140	819631	802157	819649	802165	802173	819656	802181	819664

5/List of Replaceable Parts

Table 5-14. A13 Full-Width Clip Modules

REFERENCE DESIGNATOR	FLUKE STOCK	MFRS SPLY	MANUFACTURERS PART NUMBER	TOT	R	N
-A>-NUMERICS--> S-----DESCRIPTION-----	--NO--	-CODE-	--OR GENERIC TYPE----	QTY-	-Q-	-E-
C 1, 4	407361	72982	8121-A100-WSR-103M	2		
C 2, 3	597575	72982	RPE11025U104M50V	2		
H 1	800656	COMMERCIAL		4		
J 1, 2	800680	50541	KA33/127BPMD11T	2	1	
J 3, 4		89536		2		1
MP 1		89536		1	2	1
MP 2	757500	05276	4521-0	1	2	
MP 3	773895	89536	773895	1		
MP 4	802132	89536	802132	1		
MP 5	802124	89536	802124	1		
MP 6	767954	89536	767954	2		
MP 7		89536		1		1
P 1- 4	800698	88245	1781B-1	2		
S 1	782433	5N615	B3F-3122	1	1	
S 2	408559	00779	435166-2	1		
W 1		89536		1		1
W 2	801704	89536	801704	1	1	

An * in 'S' column indicates a static-sensitive part.

NOTES:

1 - Refer to the table below for appropriate part numbers for each type of Clip Module:

	MODULE		
	-28D	-28S	-40D
MP1	800102	821975	800110
W1	801688	801688	801696
J3,4	801928	801928	801936
MP7	802199	819672	802207

5/List of Replaceable Parts

Table 5-15. A14 Calibration Module

REFERENCE DESIGNATOR		FLUKE STOCK	MFRS SPLY	MANUFACTURERS PART NUMBER	TOT	R	N
-A->NUMERICS->	S	DESCRIPTION	NO	CODE	OR GENERIC TYPE	QTY	Q E
H	1	SCREW, MACH, PHP, STL, 4-40 X 5/8	800656	COMMERCIAL		7	
J	1, 2	CONN, RECT, PWB, PLUG, 33 POS	800680	50541 KA33/127BPMD11T		2	1
MP	2	TEST LEAD, CLIP-TO-CLIP, BLK, 20AWG	801050	05276 E11395-36-0		1	1
MP	3	CABLE TIE, 4"L, 0.100"W, 0.75 DIA	172080	06383 SST1M		2	
MP	4	BUTTON, SWITCH	773895	89536 773895		1	
MP	5	MODULE BOTTOM, DOUBLE	802132	89536 802132		1	
MP	6	MODULE TOP, DOUBLE	802124	89536 802124		1	
MP	7	KEY, EXTENDED	767954	89536 767954		2	
MP	8	MODULE DECAL, CALIBRATION	802223	89536 802223		1	
P	1- 4	BANANA PLUG, PWB, SOLDER OR SWAGE TYPE	800698	88245 1781B-1		2	
S	1	SWITCH, PUSHBUTTON, SPST, MOMENTARY	782433	5N615 B3F-3122		1	1

An * in 'S' column indicates a static-sensitive part.

5/List of Replaceable Parts

Table 5-16. A15 Flying Lead Module

REFERENCE DESIGNATOR		DESCRIPTION	FLUKE STOCK	MFRS SPLY	MANUFACTURERS PART NUMBER	TOT	R	N
-A>-NUMERICS->	S		--NO--	-CODE-	--OR GENERIC TYPE----	QTY-	-Q-	-E-
C	1	CAP,CER,0.1UF,+20%,50V,25U	597575	72982	RPE11025U104M50V	1		
C	2	CAP,CER,0.01UF,+20%,100V,X7R	407361	72982	8121-A100-W5R-103M	1		
H	1	SCREW, MACH, PHP, STL, 4-40 X 5/8	800656	COMMERCIAL		4		
J	1	CONN,RECT,PWB,PLUG,33 POS	800680	50541	KA33/127BPMD11T	1	1	
MP	1	BUTTON, SWITCH	773895	89536	773895	1		
MP	2	MODULE BOTTOM, SINGLE	768697	89536	768697	1		
MP	3	MODULE TOP, SINGLE	774034	89536	774034	1		
MP	4	KEY	773952	89536	773952	2		
MP	5	MODULE DECAL	802215	89536	802215	1		
MP	6	CLIP, HOOK	757500	05276	4521-0	25	10	
P	1, 2	BANANA PLUG,PWB,SOLDER OR SWAGE TYPE	800698	88245	1781B-1	2		
S	1	SWITCH,PUSHBUTTON,SPST,MOMENTARY	782433	5N615	B3F-3122	1	1	
S	2	SWITCH,DIP,SPST,4 POS	408559	00779	435166-2	1		
W	1	CABLE ASSY, 10 PAIR, POS 1-10	801712	89536	801712	1		
W	2	CABLE ASSY, 10 PAIR, POS 1-10	801720	89536	801720	1		

An * in 'S' column indicates a static-sensitive part.

5/List of Replaceable Parts

Table 5-17. A16 512K RAM Module
(See Figure 5-12.)

REFERENCE DESIGNATOR		FLUKE STOCK	MFRS SPLY	MANUFACTURERS PART NUMBER	TOT QTY	R S	N T
-A>-NUMERICS-->	S-----DESCRIPTION-----	--NO--	-CODE-	-OR GENERIC TYPE-----		-Q	-E-
C 1- 22	CAP,CER,0.1UF,+/-10%,25V,X7R,1206	747287	72982	GRM42-6X7R104K25VPB	22		
C 23	CAP,CER,47PF,+/-10%,50V,COG,1206	747352	72982	GRM42-6COG470K50VPB	1		
U 1- 9, 11-	* IC, NMOS, 256K X 1 DRAM, 120NSEC, PLC	808212	01295	TM4256-12FML	18	1	
U 19	*	808212					
U 10	* IC,ALSTTL,OCTAL BUS TRANSCEIVER,SOIC	799593	01295	SN74ALS245ADWR	1	1	
U 20	* IC,ALSTTL,QUAD 2 INPUT NAND GATE,SOIC	782268	01295	SN74ALS00ADR	1	1	
U 21	* IC,ALSTTL,QUAD 2 INPUT OR GATE,SOIC	742460	01295	SN74ALS32DR	1	1	
U 22	* IC,ALSTTL,DUAL JK F/F,-EDG TRG,SOIC	807578	01295	SN74ALS112ADR	1	1	

An * in 'S' column indicates a static-sensitive part.

NOTE

The 9105A-007 uses two A16 512K RAM Modules.

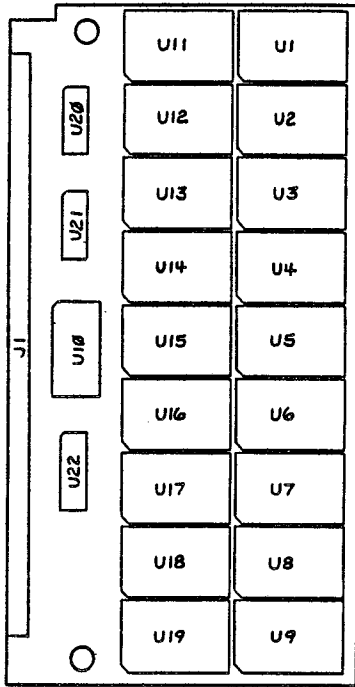

CKT 4

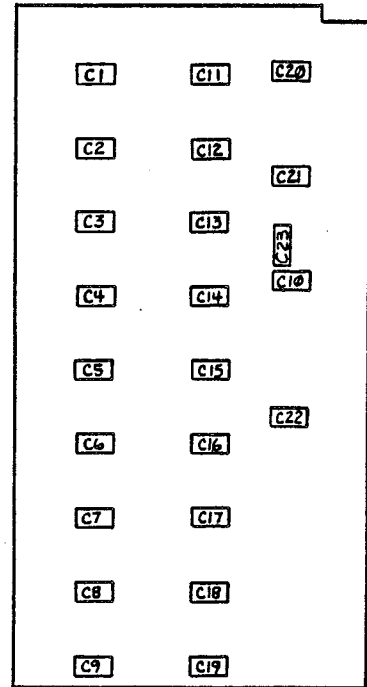

CKT 1

9100A-1616

Figure 5-12. A16 512K RAM Module

5/List of Replaceable Parts

Table 5-18. A19 Monochrome Monitor

REFERENCE DESIGNATOR	FLUKE STOCK	MFRS SPLY	MANUFACTURERS PART NUMBER	TOT QTY	R S T	N O			
-A>-NUMERICS-----> S-----DESCRIPTION-----	--NO--	-CODE-	-OR GENERIC TYPE-----	QTY-	-Q-	-E-			
BT 1			POWER SUP, 40W, +583.5A, +1282A, -1281A	769406	61852	XL40-3621	1		
H 1			SCREW, MACH, PH, P, STL, 10-32X0.375	114314	73734	19084	4		
H 2			WASHER, FLAT, STEEL, 0.203X0.434X0.031	110262	COMMERCIAL		3		
H 3			WASHER, FLAT, STL, .149, .375, .031	110270	COMMERCIAL		8		
H 4			SCREW, MACH, PH, P, STL, 6-32X0.375	152165	COMMERCIAL		8		
H 5			SCREW, MACH, SEMS, PH, P, STL, 6-32X0.375	177022	COMMERCIAL		3		
H 6			SCREW, MACH, SEMS, PH, P, STL, 6-32X0.375	177022	COMMERCIAL		5		
H 7			SCREW, MACH, PHP SEMS, STL, 4-40X1/4	185918	COMMERCIAL		6		
H 8			CONN ACC, D-SUB, LATCH BLOCK, SHORT, 4-40	783480	00779	745403-9	2		
H 9			SCREW, MACH, PH, P, STL, 6-32X1.000	114215	COMMERCIAL		3		
H 10			WASHER, FLAT, STL, .149, .375, .031	110270	88044	AN960-6	3		
H 11			SCREW, MACH, SEMS, PH, P, STL, 6-32X0.375	177022	COMMERCIAL		4		
MP 1			BRACKET, CRT, FINISHED	794149	89536	794149	4	1	
MP 2			LABEL, BAR-CODE, 9.4 CPI, 0.245X1.25	807099	89536	807099	2		
MP 3			CHASSIS, FINISHED	794156	89536	794156	1		
MP 4			SPACER, PWB, NYL, .312	780619	30838	215-150913-01	3		
MP 5			BEZEL ASSY, 9100	792903	89536	792903	1		
MP 6			GASKET, TOUCH PANEL, DUST	843250	89536	843250	1		
MP 7			NAMEPLATE	787275	89536	787275	1		
MP 8			COVER, CHASSIS, 9100, FINISHED	794198	89536	794198	1		
MP 9			DAMPER, VIBRATION	805085	89536	805085	4		
MP 10			CABLE TIE ANCHOR, ADHSV, 0.160*TIE	407908	06383	ABMM-A-C	5		
MP 11			CABLE TIE, 4*L, 0.100*W, 0.75 DIA	172080	06383	SST2M	8		
MP 12			DECAL, COVER, 9100	792911	89536	792911	1		
MP 13			DECAL, FAN PANEL	785493	89536	785493	1		
MP 14			BRACKET, POT MOUNTING, FINISHED	794131	89536	794131	1		
MP 15			THUMBWHEEL, POTENTIOMETER	787358	89536	787358	1		
MP 16			SHIPPING BOX	776435	89536	776435	1		
MP 17			SHIPPING INSERT	777045	89536	777045	1		
MP 18			OPTION TRAY	801613	89536	801613	1		
MP 19			SHIPPING CARRIER/INSERT	777052	89536	777052	1		
MP 20			INSERT, OPTION TRAY	809616	89536	809616	1		
MP 21			ENCLOSURE W/GRILLS	802454	89536	802454	1		
MP 22			COVER, FAN	787366	89536	787366	1		
MP 23			DECAL, CAUTION	787242	89536	787242	1		
MP 24			BASE	747972	89536	747972	1		
MP 25			RETAINER, NUT	749655	89536	749655	1		
MP 26			BUSHING COVER RF OUTPUT	802553	89536	802553	1		
MP 27			SHOULDER WASHER	792861	89536	792861	2		
MP 28			RETAINER PIN	802520	89536	802520	1		
MP 29			BASE, MOUNTING PLATE	747998	89536	747998	1		
MP 30			FOOT, RUBBER, SELF-ADHESIVE, BLACK	513820	28213	SJ5012	4		
MP 31			PIN, MECHANICAL, CLEVIS, 5/16 X 1-3/4	800524	96652	11-099	1		
MP 32			SPRING, COIL, COMP, SQUARED END, M WIRE	800532	83553	C1100-125-0880M	1		
MP 33			BUMPER, STEM, BUNA-S, 0.500X0.125	800839	59000	6171	4		
MP 34			ASSY, AC POWER PANEL	776377	89536	776377	1		
MP 35			DISPLAY, MONITOR GREEN	785444	89536	785444	1		
MP 36			CONTRAST OVERLAY	819987	89536	819987	0	1	1
W 1			CORD, LINE, 5-15/IEC, 3-18AWG, SVT	284174	70903	17239	1		
W 2			CABLE ASSY, 9100	778613	89536	778613	1		

An * in 'S' column indicates a static-sensitive part.

NOTE 1 - Contrast overlay is part of the bezel assembly..

5/List of Replaceable Parts

Table 5-19. Option -003 Parallel I/O Module
(See Figure 5-13.)

REFERENCE DESIGNATOR	FLUKE STOCK	MFRS SPLY	MANUFACTURERS PART NUMBER	TOT QTY	R O S T
-A>-NUMERICS----->	S-----DESCRIPTION-----	--NO--	-CODE- -OR GENERIC TYPE-----	QTY-	-Q -E-
A 7	* I/O MODULE (MAIN) PCA	768838	89536 768838	1	
A 8	* I/O MODULE (TOP) PCA	755611	89536 755611	1	
A 14	CALIBRATION MODULE	813980	89536 813980	1	
A 15	FLYING LEAD MODULE, 20 LEAD SET, TSTD	819763	89536 819763	1	
F 1	FUSE, 1/4 X 1-1/4, SLOW, 1.0A, 250V	109272	71400 MDL1A	1	5
F 1	FUSE, 5X20MM, SLOW, 1A, 250V	808055	61935 034.3117	1	5
H 1	SCREW, MACH, PHP, STL, 6-32 X 7/8	801241	COMMERCIAL	4	
H 2	SCREW, MACH, PHP SEMS, STL, 6-32X1/4	178533	COMMERCIAL	9	
MP 1	HLDR PART, FUSE, CAP, 1/4X1-1/4	460238	61935 031.1666	1	
MP 2	HLDR PART, FUSE, CAP, 5X20MM	461020	61935 031.1663	1	
MP 3	CASE TOP, I/O MODULE	773291	89536 773291	1	
MP 4	CASE BOTTOM, I/O MODULE	773283	89536 773283	1	
MP 5	DECAL, CASE TOP, I/O MODULE	805630	89536 805630	1	
MP 6	DECAL, CASE BOTTOM, I/O MODULE	773382	89536 773382	1	
MP 7	SHIELD, I/O MODULE	775866	89536 775866	1	
MP 8	FOOT, NON-SKID	774000	89536 774000	4	
MP 9	NAMEPLATE, SERIAL -REAR PANEL-	472795	89536 472795	1	
MP 10	CARTON KEYBOARD, I/O	805804	89536 805804	1	
MP 11	FOAM INSERT, KEYBOARD-I/O	805812	89536 805812	1	
MP 12	CONVOLUTED FOAM, KEYBOARD-I/O	805820	89536 805820	1	
W 1	CABLE ASSEMBLY, EXTERNAL EVENT	773945	89536 773945	1	1
W 2	CABLE ASSY, I/O MODULE	783977	89536 783977	1	
W 3	WIRE, SHIELD CONTACT	803122	89536 803122	1	

An * in 'S' column indicates a static-sensitive part.

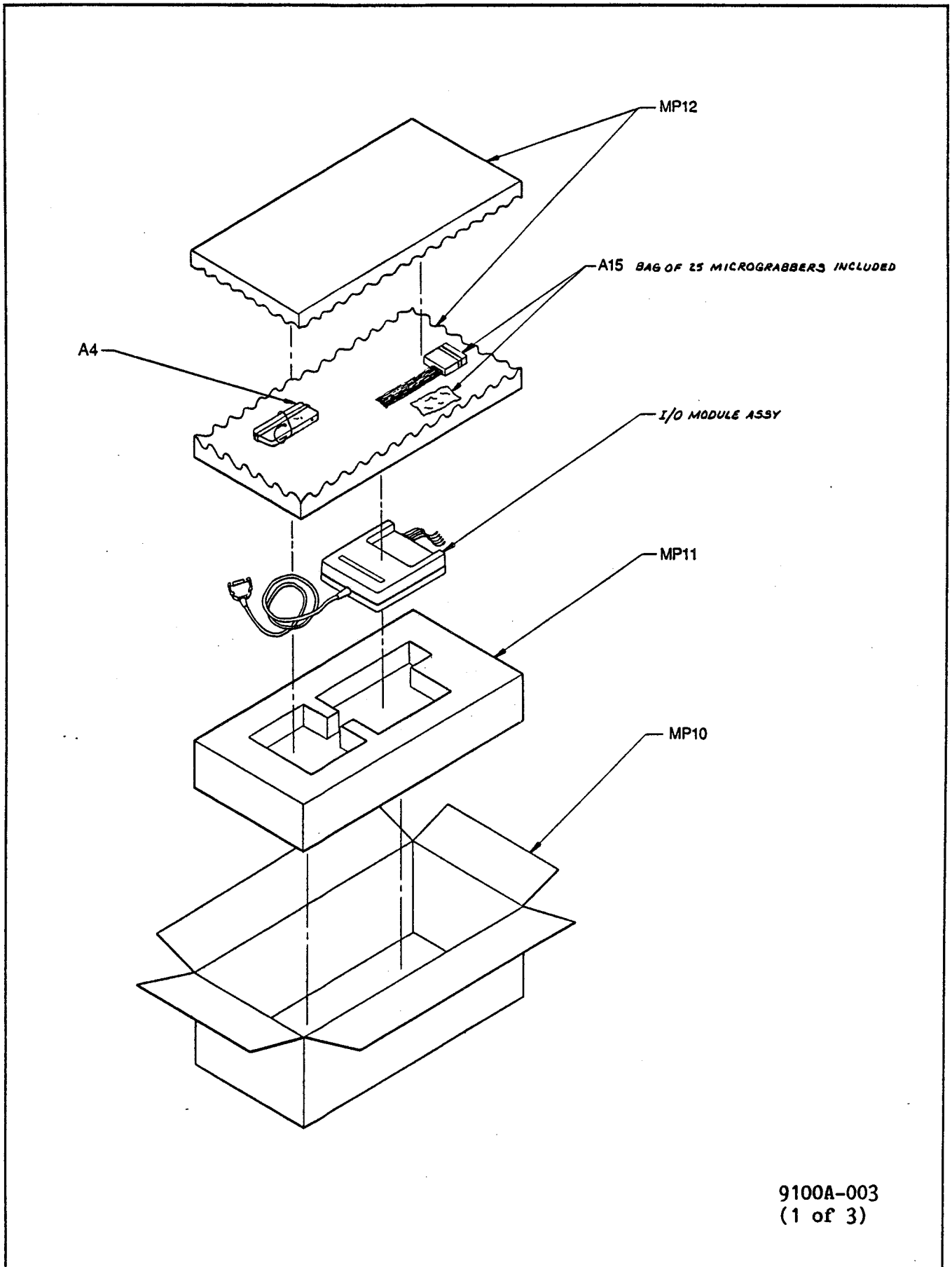

9100A-003
(1 of 3)

Figure 5-13. Option -003 Parallel I/O Module

5/List of Replaceable Parts

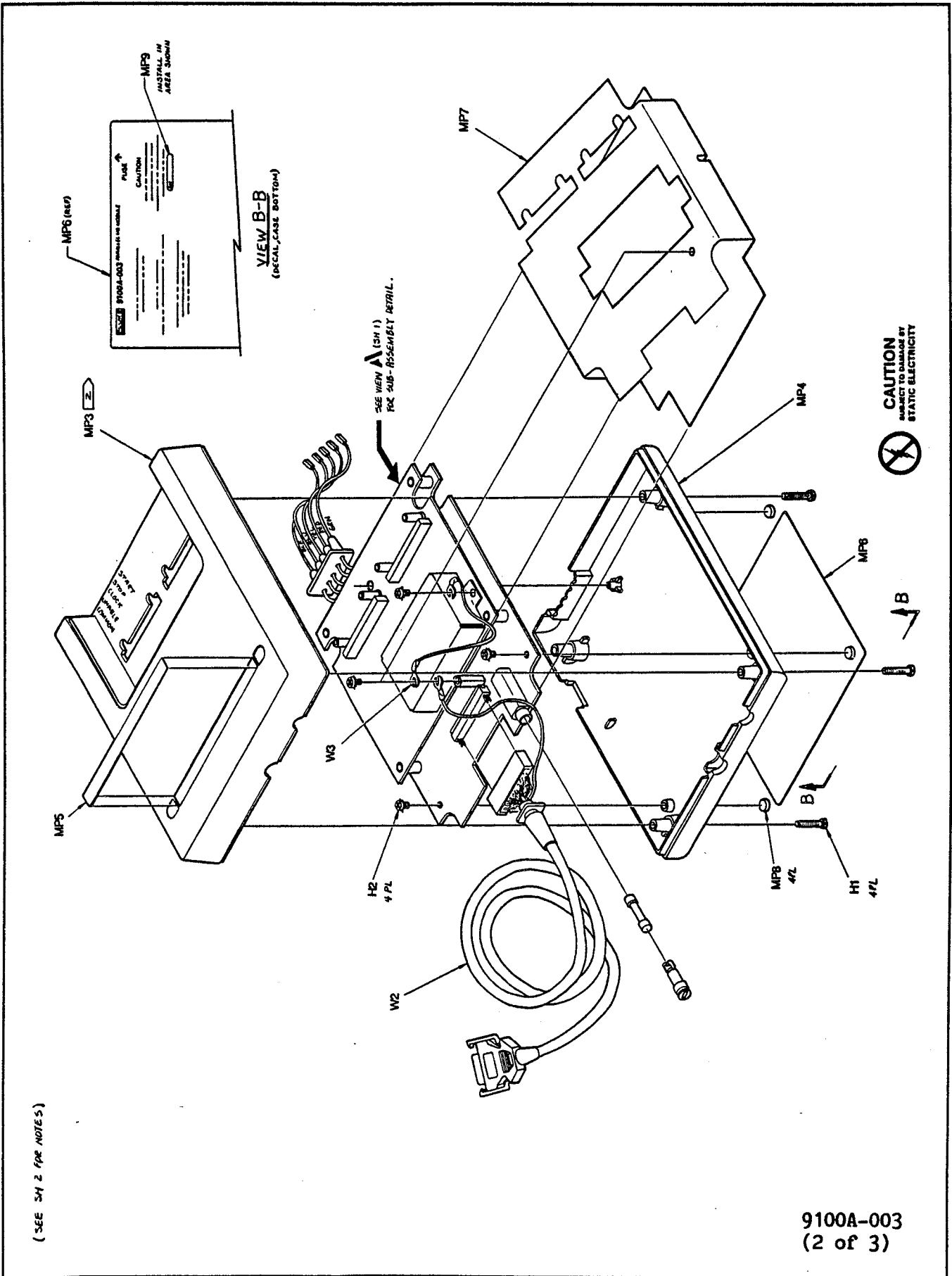
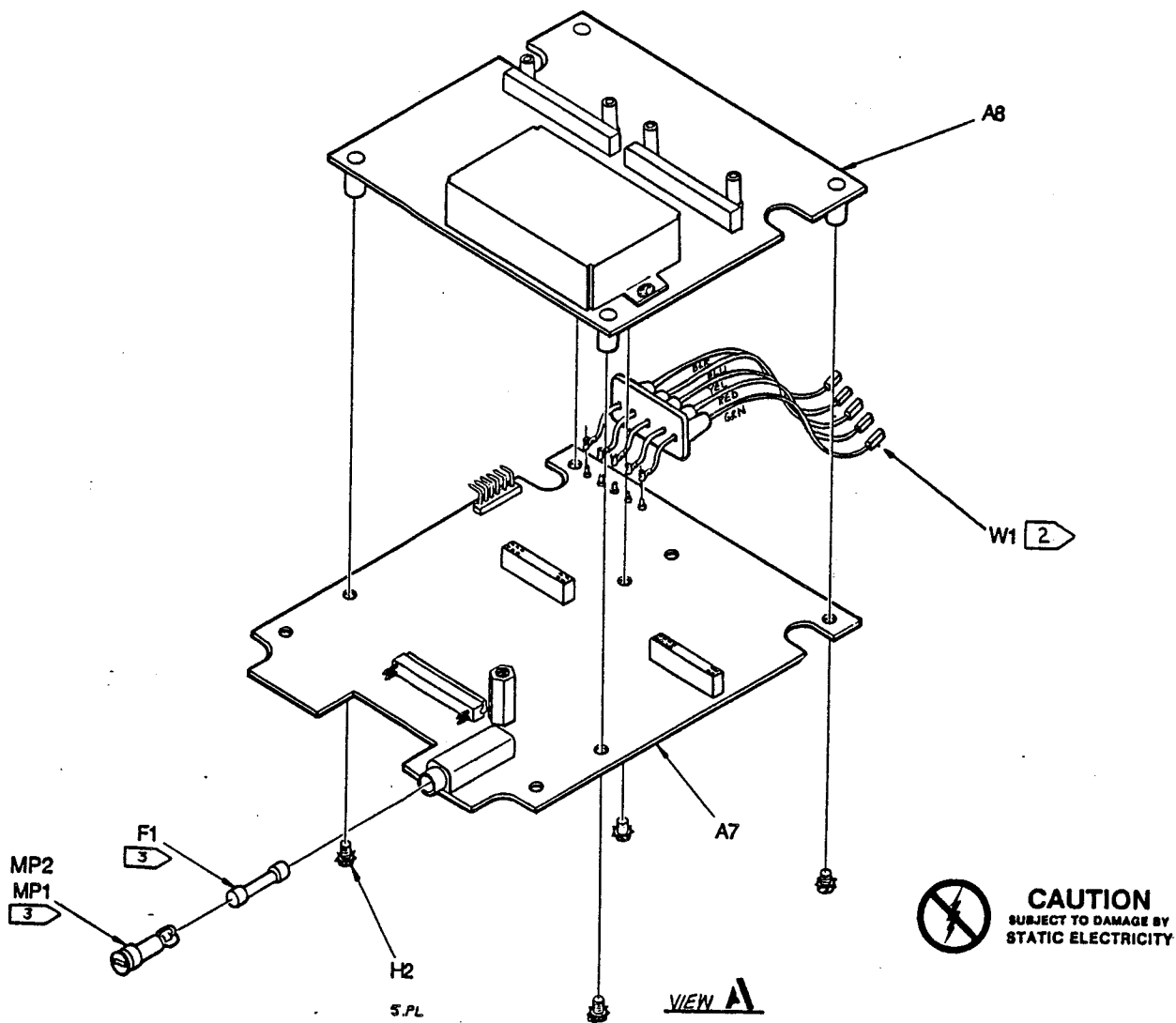

Figure 5-13. Option -003 Parallel I/O Module (cont.)



NOTES: UNLESS OTHERWISE SPECIFIED.

1. **WARNING:** Ⓢ INDICATES USAGE OF MOS DEVICE(S) WHICH MAY BE DAMAGED BY STATIC DISCHARGE. USE SPECIAL HANDLING PER S.O.P. 18.1

2. CABLE NOMENCLATURE ON MP3 CASE TOP SHALL MATCH UP WITH COLORS OF W1 AS NOTED:
 COMMON - BLACK WIRE
 UNABLE - BLUE WIRE
 CLOCK - YELLOW WIRE
 STOP - RED WIRE
 START - GREEN WIRE

3. FUSE & FUSE CAP VARY FOR DIFFERENT VOLTAGE CONFIGURATIONS: SEE FUSE CHART FOR FUSE & CAP PART NO.S.

FUSE CHART			3	CONFIGURATION
VOLTAGE	FUSE	CAP		
100/120V	109272	460238	115V	763649
220/240V	808055	461020	230V	763656

9100A-003
(3 of 3)

Figure 5-13. Option -003 Parallel I/O Module (cont.)

5/List of Replaceable Parts

Table 5-20. Option -004 Programmer's Station, Monochrome
(See Figure 5-14.)

REFERENCE DESIGNATOR		FLUKE STOCK	MFRS SPLY	MANUFACTURERS PART NUMBER	TOT	N R O S T
-A>-NUMERICS-->	S-----DESCRIPTION-----	--NO--	-CODE-	-OR GENERIC TYPE-----	QTY-	-Q -E-
A 4	* VIDEO CONTROLLER PCA	768762	89536	768762	1	
A 19	MONOCHROME MONITOR	826362	89536	826362	1	
A 103	KEYBOARD, ASYNC ASCII, 1200 BAUD	757120	76854	5-64995-131	1	1
H 1	RIVET, POP, DOME, AL, 0.125X0.316	423616		COMMERCIAL	2	
MP 2	VIDEO CONNECTOR BRACKET	768648	89536	768648	1	
MP 3	NAMEPLATE, SERIAL -REAR PANEL-	472795	89536	472795	1	
MP 4	PROGRAMMER SOFTWARE SYSTEM, SLEEVED		89536		1	2
MP 5	CARTON KEYBOARD, I/O	805804	89536	805804	1	
MP 6	CONVOLUTED FOAM, KEYBOARD-I/O	805820	89536	805820	1	
MP 7	PROGRAM COPY PROTECTION SHEET	847066	89536	847066	1	
TM 1	9100A TL/1 REFERENCE MANUAL	818047	89536	818047	1	
TM 2	9100A PROGRAMMERS MANUAL	813857	89536	813857	1	
U 5	* PROGRAMMED 27128-150	818195	89536	818195	1	
W 1	CABLE, MONITOR	787903	89536	787903	1	
Z 1	JUMPER, DIP, 0.300CTR, PROGRAM, 16 POS	783183	51167	16-680-191T	1	

An * in 'S' column indicates a static-sensitive part.

NOTES:

- 1 - See 9100A-013 option for replacement parts breakdown for A103.
- 2 - This software available only for 9100A's with Programmer's Station installed. Contact the factory if replacement is needed.

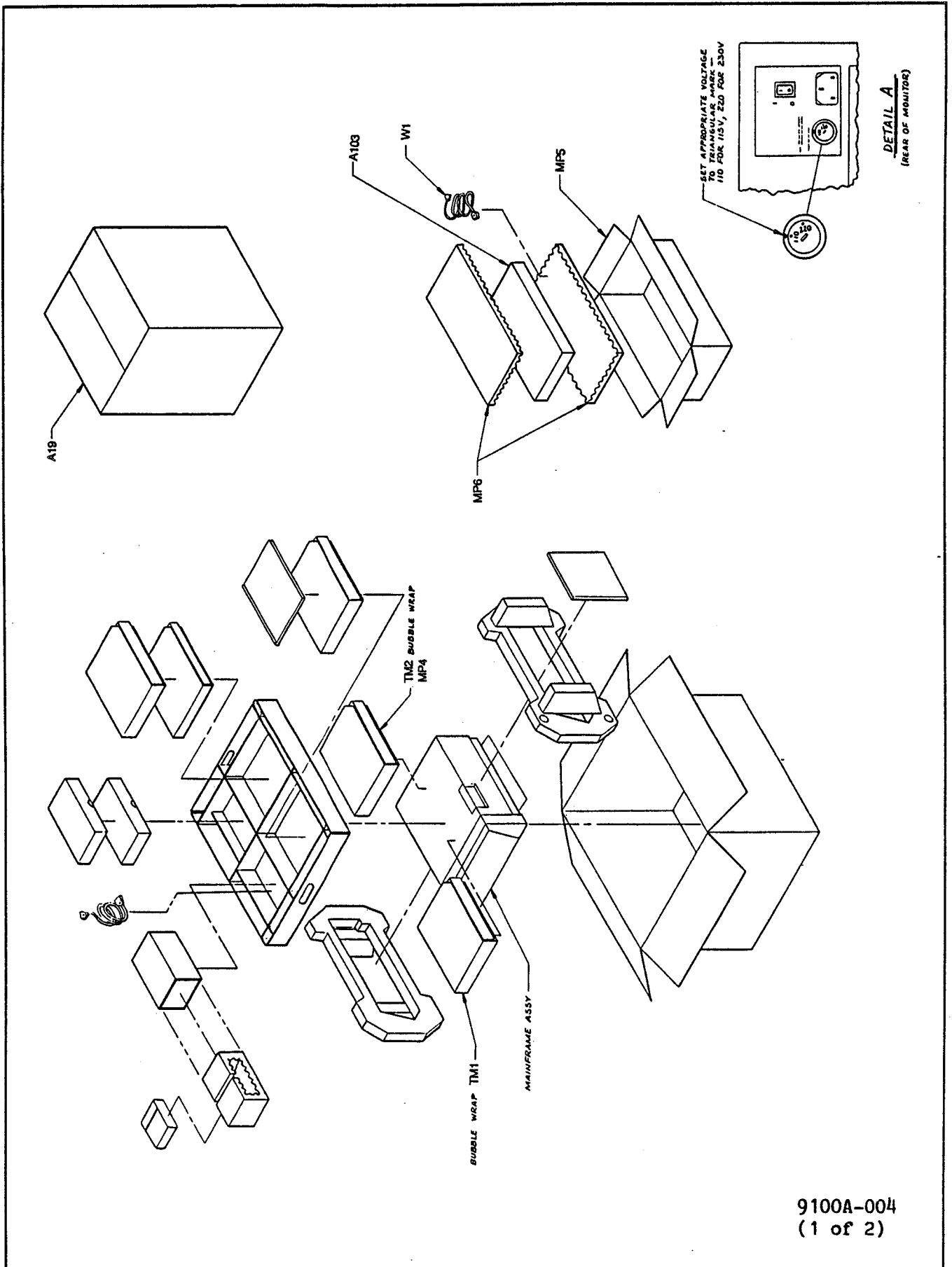

Figure 5-14. Option -004 Programmer's Station, Mono

5/List of Replaceable Parts

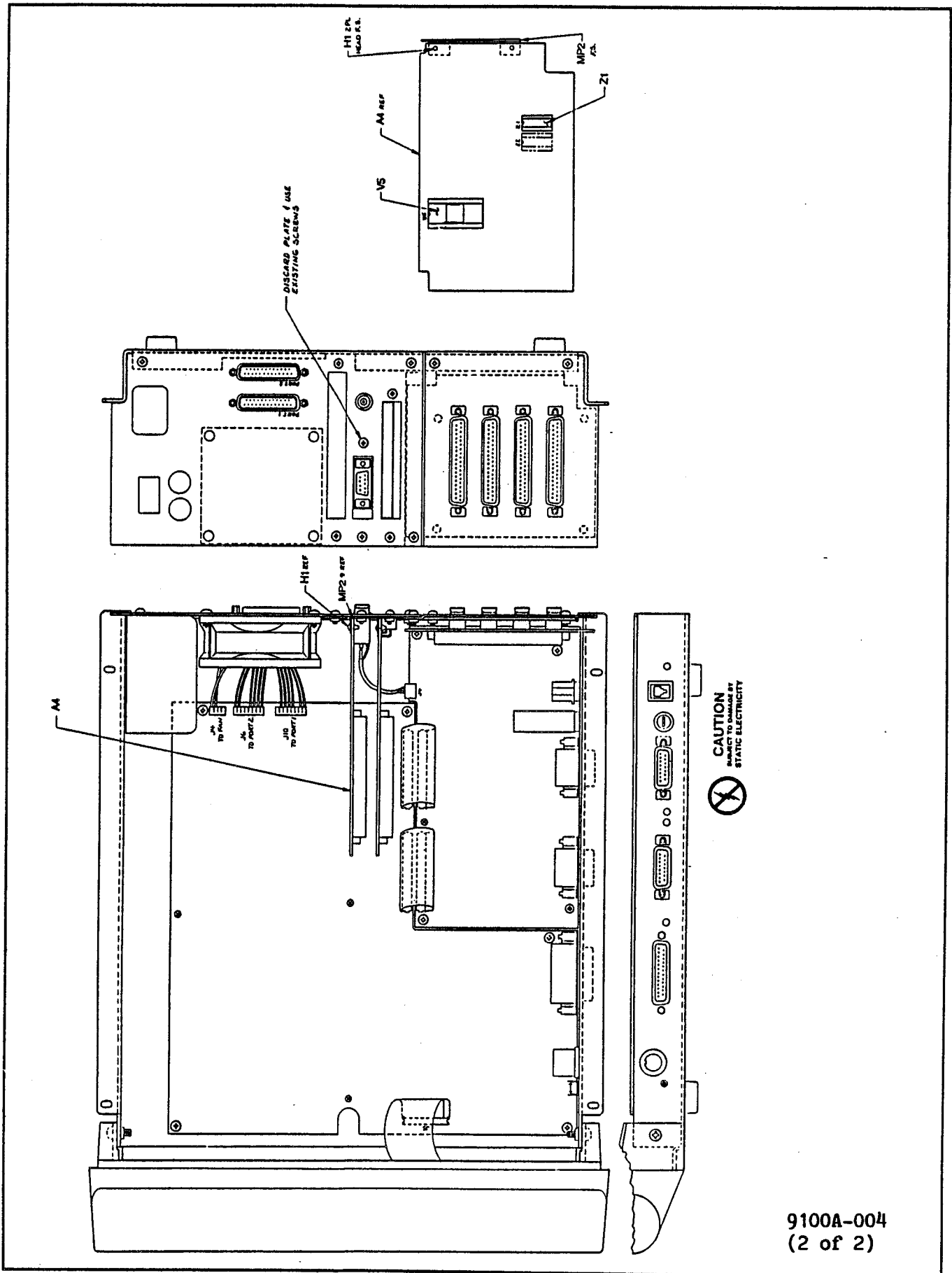

Figure 5-14. Option -004 Programmer's Station, Mono (cont.)

5/List of Replaceable Parts

Table 5-21. Option -005 Programmer's Station, Color
(See Figure 5-15.)

REFERENCE DESIGNATOR	FLUKE STOCK	MFRS SPLY	MANUFACTURERS PART NUMBER	TOT QTY	R S T	N O
-A>-NUMERICS-->	S	--NO--	-CODE- --OR GENERIC TYPE----	QTY-	-Q	-E-
A 4	*	768762	89536 768762	1		
A 103		757120	76854 5-64995-131	1		1
H 1		187625	COMMERCIAL	2		
MP 2		768648	89536 768648	1		
MP 3			89536	1		2
MP 4		805804	89536 805804	1		
MP 5		805820	89536 805820	1		
MP 6		847066	89536 847066	1		
TM 1		818047	89536 818047	1		
TM 2		813857	89536 813857	1		
U 5	*	818195	89536 818195	1		
Z 2		783183	51167 16-680-191T	1		

An * in 'S' column indicates a static-sensitive part.

NOTES:

- 1 - See 9100A-013 option for replacement parts breakdown for A103.
- 2 - This software available only for 9100A's with Programmer's Station installed. Contact the factory if replacement is needed.

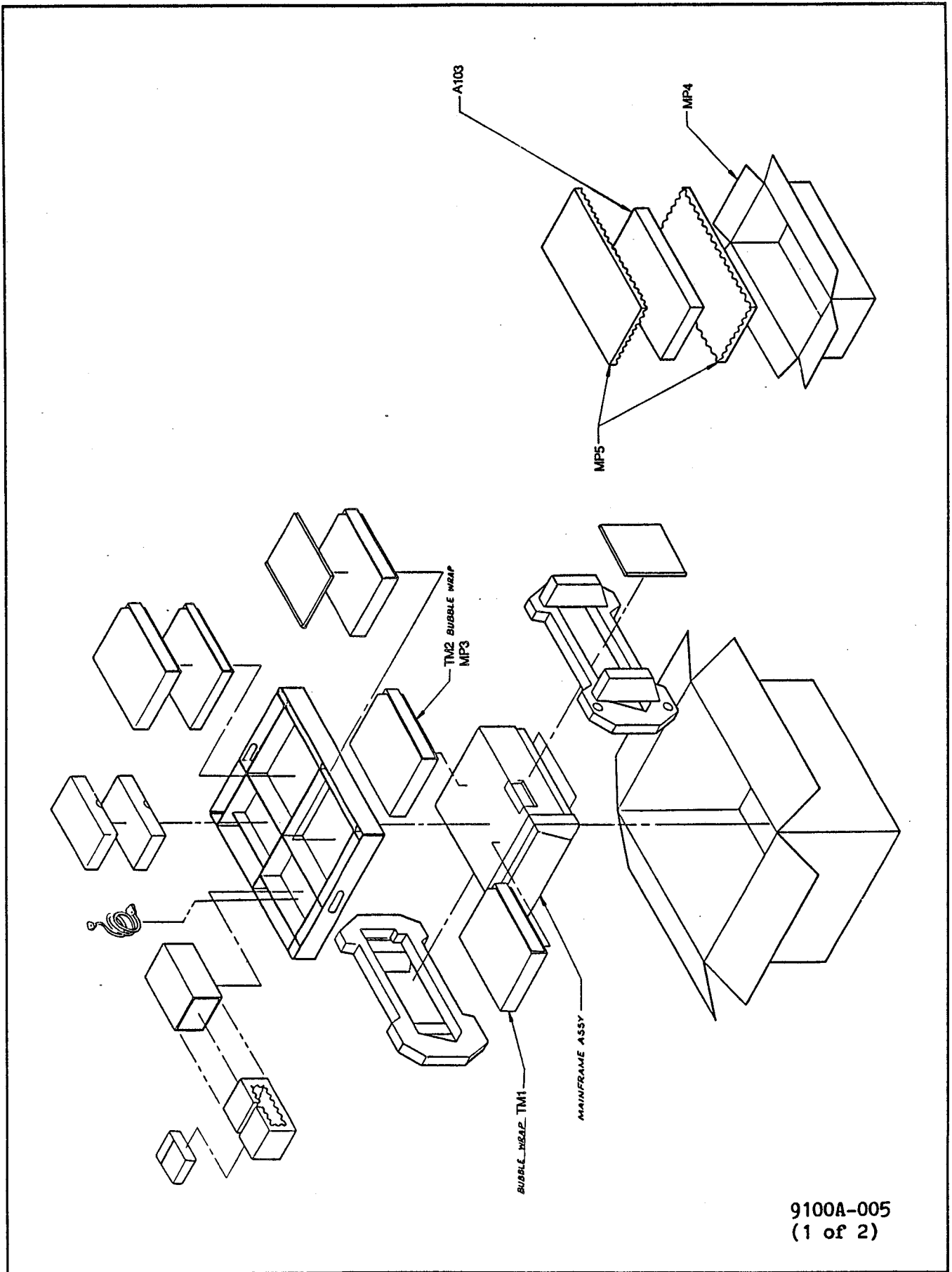

Figure 5-15. Option -005 Programmer's Station, Color

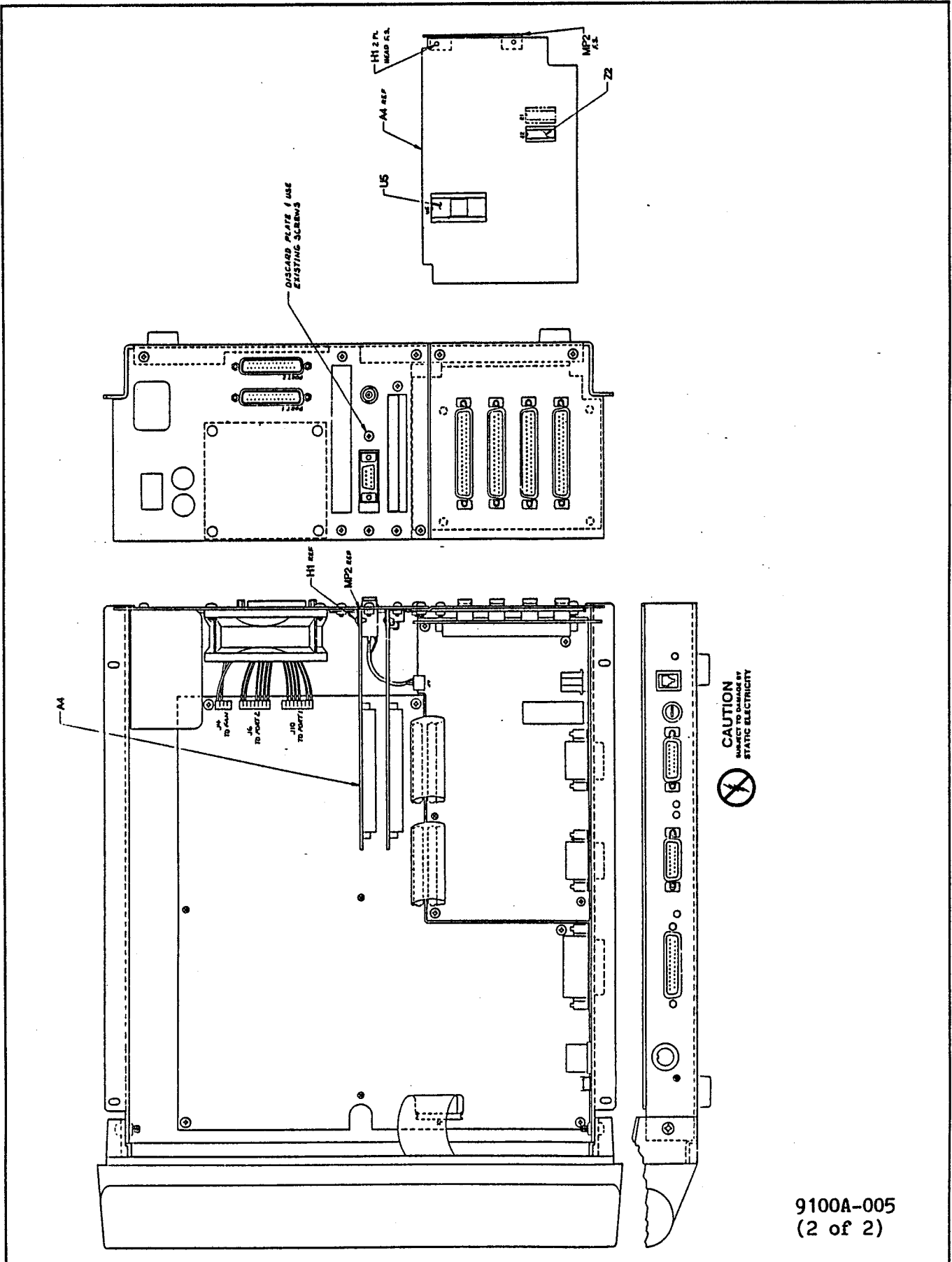

Figure 5-15. Option -005 Programmer's Station, Color (cont.)

5/List of Replaceable Parts

Table 5-23. Option -009 Video, Monochrome
(See Figure 5-17.)

REFERENCE DESIGNATOR		FLUKE STOCK	MFRS SPLY	MANUFACTURERS PART NUMBER	TOT	R S	N O T
-A>-NUMERICS----->	S-----DESCRIPTION-----	--NO--	-CODE-	-OR GENERIC TYPE-----	QTY-	-Q-	-E-
A	4 * VIDEO CONTROLLER PCA	768762	89536	768762	1		
A	19 MONOCHROME MONITOR	826362	89536	826362	1		
H	1 RIVET,POP,DOME,AL,0.125X0.316	423616	COMMERCIAL		2		
MP	2 VIDEO CONNECTOR BRACKET	768648	89536	768648	1		
MP	3 NAMEPLATE, SERIAL -REAR PANEL-	472795	89536	472795	1		
U	5 * PROGRAMMED 27128-150	818195	89536	818195	1		
W	1 CABLE, MONITOR	787903	89536	787903	1		
Z	1 JUMPER,DIP,0.300CTR,PROGRAM,16 POS	783183	51167	16-680-191T	1		

An * in 'S' column indicates a static-sensitive part.

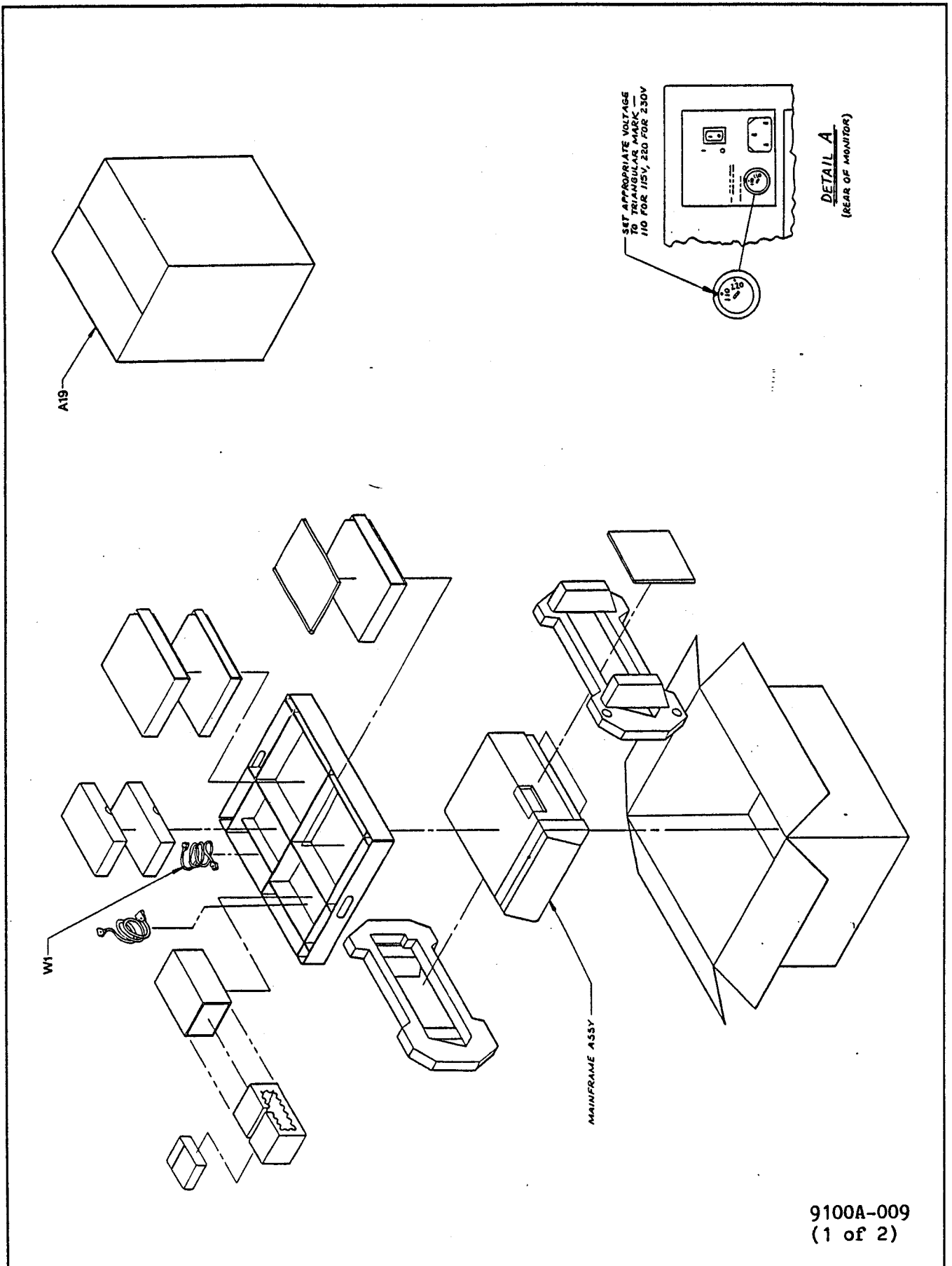

9100A-009
(1 of 2)

Figure 5-17. Option -009 Video, Monochrome
5-59

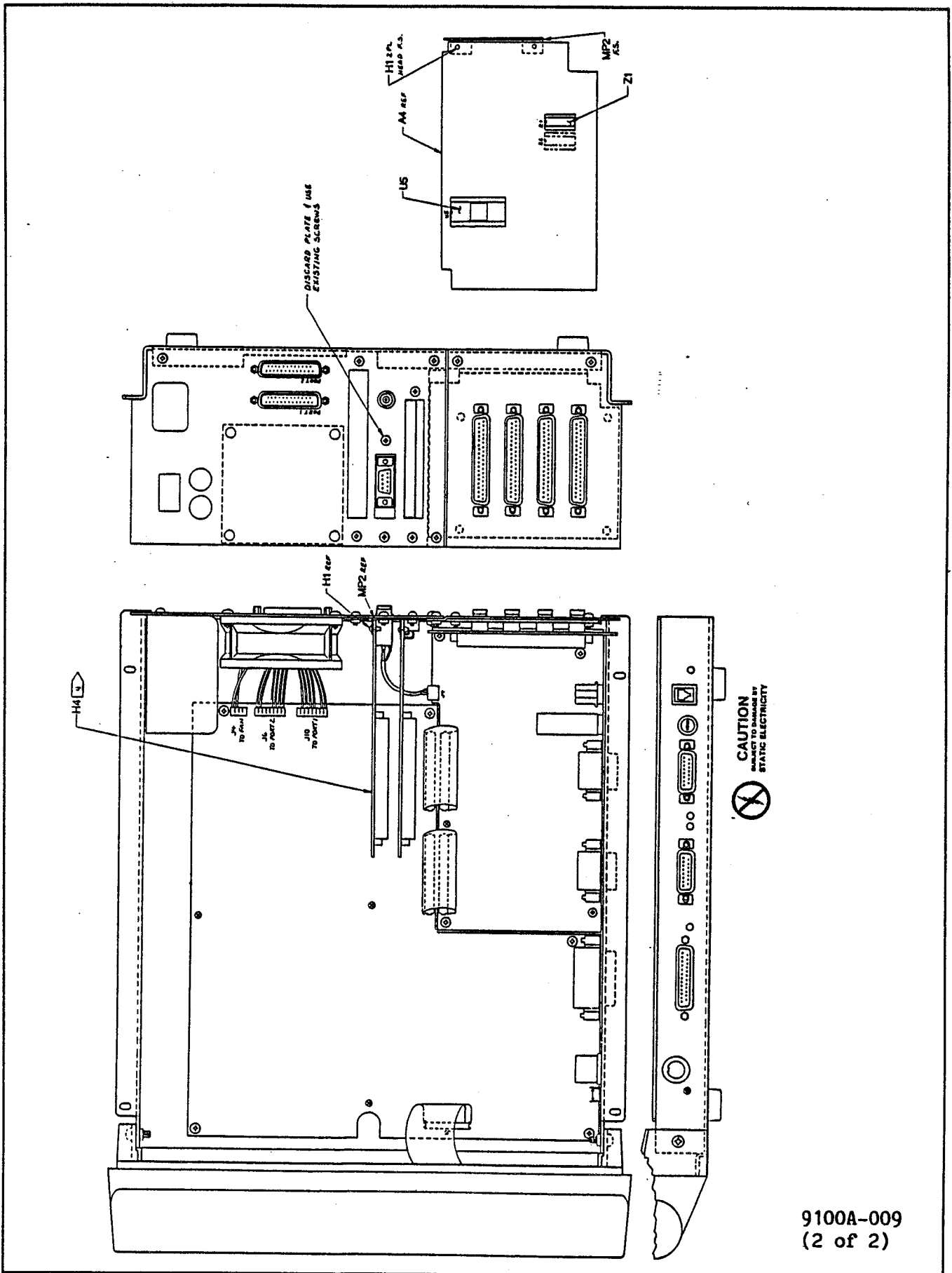

Figure 5-17. Option -009 Video, Monochrome (cont.)

5/List of Replaceable Parts

Table 5-24. Option -011 Video, Color
(See Figure 5-18.)

REFERENCE DESIGNATOR		FLUKE STOCK	MFRS SPLY	MANUFACTURERS PART NUMBER	TOT	R	N
-A>-NUMERICS----->	S-----DESCRIPTION-----	--NO--	-CODE-	-OR GENERIC TYPE-----	QTY-	-Q	-E-
A	4						
	* VIDEO CONTROLLER PCA	768762	89536	768762	1		
H	1	423616	COMMERCIAL		2		
MP	2	768648	89536	768646	1		
U	5	818195	89536	818195	1		
Z	2	783183	51167	16-680-191T	1		

An * in 'S' column indicates a static-sensitive part.

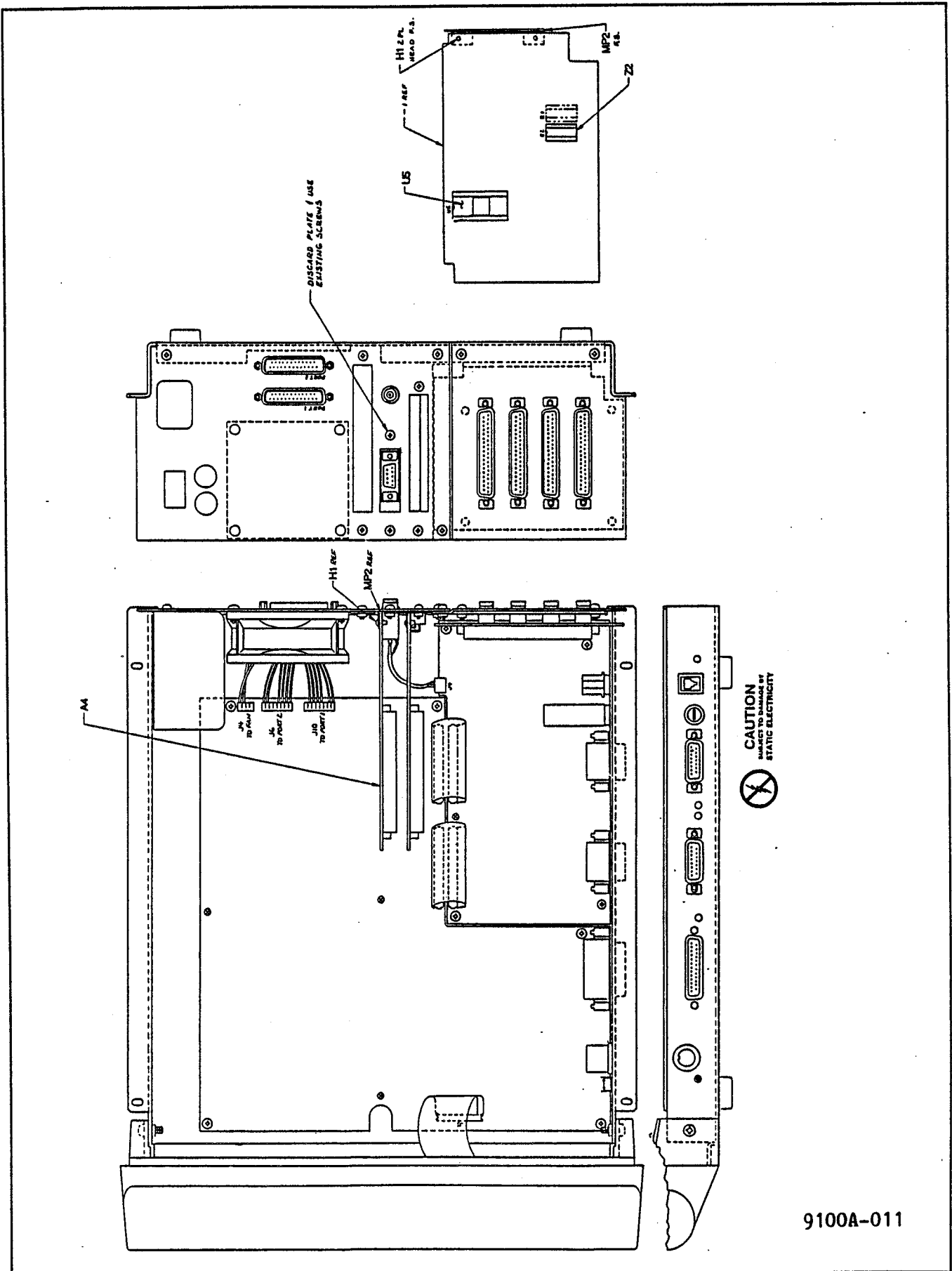

9100A-011

Figure 5-18. Option -011 Video, Color

5/List of Replaceable Parts

Table 5-25. Option -013 Programmer's Keyboard

REFERENCE DESIGNATOR	FLUKE STOCK	MFRS SPLY	MANUFACTURERS PART NUMBER	TOT	R	N
-A>-NUMERICS-----> S-----DESCRIPTION-----	NO--	CODE-	-OR GENERIC TYPE-----	QTY-	-Q	-E-
MP 1	783092	76854	4-6474-003	1		
MP 2	783076	76854	5-64955-100	1		
MP 3	783118	76854	5-68585-115	1		
MP 4	783035	76854	3-8779-524	1		
MP 5	783084	76854	3-3314-762	1		
W 1	783043	76854	4-6378-008	1		

An * in 'S' column indicates a static-sensitive part.



CONTENTS

Section 1. How to Use This Manual

Introduction	1-3
This Manual	1-3
The Manual Set	1-5
Conventions	1-6

Section 2. General Information

Description	2-3
Power Requirements	2-3
External Connections	2-3
System Components	2-6
9100A System	2-6
9105A System	2-6
Options	2-6
Accessories	2-7
Interface Pods	2-7
Required Test Equipment	2-7
Shipping Information	2-7
Service Information	2-7
Specifications	2-10

Section 3. Theory of Operation

Overview	3-5
Main PCA	3-5
RS-232 Ports	3-5
Micro Floppy Disk System	3-5
Hard Disk System	3-6
Power Supply	3-6
Operator's Display	3-6
Operator's Keypad	3-6
Probe/Pulser	3-6
Clock Module	3-6
Monitor	3-6
Programmer's Keyboard	3-7
I/O Module	3-7
Main PCA (MC68000 Microprocessor)	3-7
Overview	3-7

Table of Contents

Section 3. Theory of Operation (cont.)

Signal and Pin Description	3-7
Signal Description	3-7
Signal Organization	3-13
Address/Data Bus Operation	3-14
Address Bus	3-14
Data Bus	3-14
Bus Operation During Data Transfer	3-14
The Read Cycle	3-15
The Write Cycle	3-15
The Read-Modify-Write Cycle	3-15
Bus Arbitration	3-16
Bus Error and Halt	3-16
Privilege Modes	3-17
Exception Processing	3-17
Interrupts	3-18
Asynchronous Execution	3-23
Reset Signal Description and Generation	3-23
Address Decoding and DTACK	3-24
RAM	3-24
RAM Configuration	3-24
RAM Timing	3-25
RAM Refresh	3-25
RAM Parity	3-26
ROM	3-26
Pod Interface	3-27
DUART-Timer-I/O	3-30
Microfloppy Disk System	3-33
Disk Drive	3-33
Floppy Drive Controller	3-33
Interrupts	3-35
Hard Disk System	3-35
Power Supply	3-35
Operator's Display	3-35
Vacuum-Fluorescent Display (VFD)	3-35
Displayable Characters	3-38
Annunciators	3-42
Operator's Keypad	3-42
Probe I/O Module Interface	3-43
Overview	3-43
Probe I/O Module Interface Addressing	3-46
Probe Interface	3-46
Probe Data Input	3-47
Threshold Voltage Calculation	3-47
Probe Operation Voltages	3-49
Fuse Blown Detection	3-49
Probe Light Drive and Control	3-49
External 16-bit Counter	3-49
Clock Module Interface	3-50
Custom Delay Chip	3-50
Custom Logic Chip	3-51
Stop Counter	3-53

Section 3. Theory of Operation (cont.)

I/O Module Interface Connector	3-53
I/O Module -VDRV Voltage Regulator	3-54
I/O Module Overcurrent Detection	3-55
Miscellaneous Functional Blocks	3-55
Sync Pulse Isolation	3-55
Footswitch Connector	3-56
Data Bus Buffers	3-56
Status Register	3-56
Control Register	3-57
I/O Connector Interface	3-57
Overview	3-57
Power Supplies	3-58
I/O Module Connector PCA Contents	3-58
Probe/Pulser	3-59
Overview	3-59
Probe	3-59
Probe Tip Input	3-59
Common Ground Clip	3-61
Pulser	3-61
Level Indicators	3-62
Logic Level Modes	3-62
Level Indicator Operation	3-62
Push Button Switch	3-62
Clock Module	3-63
Overview	3-63
Clock Module Operation	3-63
Clock Module Speed	3-63
Multi-Function Interface	3-63
Overview	3-63
Addresses	3-64
Clock	3-64
SCSI	3-64
Video	3-64
Video Controller	3-64
Video RAM	3-65
Video Output	3-67
Monitor	3-67
Programmer's Keyboard	3-67
I/O Module	3-68
I/O Module Overview	3-68
Bus Interface Functional Block	3-70
Overview	3-70
Addressing	3-70
Custom Chip Selection	3-75
Custom Chip Functional Block	3-75
Clock and Enable Mux Functional Block	3-75
Clock and Enable Mux Operation	3-75

Table of Contents

Section 3. Theory of Operation (cont.)

General Control Latch Functional Block	3-77
Overview	3-77
Control Register	3-77
Data Comparison Inputs	3-78
Fuse Detection	3-78
Data Comparison and General Interrupts	3-78
Operation of General Control Latch Block	3-79
Connector Code Functional Block	3-81
Input Protection/FET Output Block	3-83
I/O Module Top PCA Functional Block	3-85
DIP Clip and Calibration Module Functional Block	3-85
Overview of the Clip and Calibration Modules	3-85
Clip and Calibration Module Operation	3-86
Half Width Clip Module	3-86
Full-Width Clip Module	3-86
Calibration Module	3-86

Section 4. Maintenance

Introduction	4-3
Selecting Line Voltage	4-3
Selecting Mainframe Line Voltage	4-3
Selecting Monitor Line Voltage	4-6
Changing Fuses	4-7
Changing the Mainframe Fuse	4-7
Changing the Probe Fuse	4-7
Changing the Clock Module Fuse	4-7
Changing the I/O Module Fuse	4-8
Cleaning	4-8
General	4-8
Fan Filter	4-9
Floppy Disk Drive	4-9
Mainframe Access, Removal, and Installation Techniques	4-9
System Connections	4-9
Mainframe Access	4-9
Operator Keypad/Display	4-12
Removing the Assembly	4-12
Separating the Subassembly	4-12
Disassembling the Keypad	4-12
Disassembling the Disk System	4-14
Removing the Hard Disk Controller	4-14
Removing the Disk Drive Assemblies	4-14
Installing the Disk Drive Assemblies	4-14
Removing the Power Supply	4-14
Removing the MFI and Video Controller PCAs	4-16
Removing the I/O Connector Interface PCA	4-16
Removing the Probe I/O Module Interface PCA	4-16
Removing the Main PCA	4-16
Programmer Keyboard Access Procedure	4-17

Section 4. Maintenance (cont.)

Screen Overlay	4-18
Recommended Used	4-18
Removing the Overlay	4-18
Installing the Overlay	4-18
Monitor Access, Removal, Installation Techniques	4-19
Removing the Monitor Cover	4-19
Accessing the Monitor Chassis	4-19
Removing the Front Bezel	4-19
Monitor Power Supply	4-21
Removing the Monitor Power Supply	4-21
Installing the Monitor Power Supply	4-22
Monitor Display PCA	4-24
Removing the Display PCA	4-24
Installing the Display PCA	4-26
CRT and Yoke	4-28
Removing the CRT and Yoke	4-28
Installing the CRT and Yoke	4-30
Monitor Adjustment	4-32
Deciding on CRT Replacement	4-37
Self Test Routines	4-38
Power-Up Self Test	4-38
Probe Self Test	4-38
Pod Self Test	4-41
I/O Module Self Test	4-42
Display Self Test	4-42
Calibration	4-45
Probe Offset Correction	4-46
Probe Compensation	4-46
Software Calibration	4-48
Probe to External (Clock Module)	4-48
Probe to Pod	4-49
I/O Module to External	4-50
I/O Module to Pod	4-50
Saving and Restoring Calibration Data	4-51
Invalid Calibration Data	4-52
Saving Calibration Data	4-52
Restoring Calibration Data	4-53
Troubleshooting	4-54
Repair	4-54
General Repair	4-54
Static Awareness	4-54
Components	4-54
Surface Mount Repair	4-54
Surface Mount Technology	4-54
Repair Techniques	4-60
Tools and Supplies	4-64

Table of Contents

Section 4. Maintenance (cont.)

Repair Information	4-66
General	4-66
Main PCA	4-66
Display and Keypad	4-66
Probe I/O	4-67
I/O Connector	4-67
Single-Point Probe	4-67
Clock Module	4-67
RAM Modules	4-68
Power Supply	4-68
Floppy Disk Drive	4-69
Hard Disk and Controller	4-69
Multi-Function Interface	4-70
Video Controller	4-70
Monochrome Monitor	4-71
I/O Module	4-71
Clip and Flying Lead Modules	4-71

Section 5. List of Replaceable Parts

Section 6. Appendices

Section 7. Schematic Diagrams

LIST OF TABLES

TABLE	TITLE	PAGE
2-1.	Power Requirements	2-3
2-2.	Required Tools and Test Equipment	2-8
2-3.	Specifications	2-10
3-1.	Signal Descriptions	3-10
3-2.	Data Strobe Control	3-12
3-3.	Address Ranges	3-14
3-4.	Interrupt Vector Table	3-19
3-5.	Microprocessor Status Latches U61 & U62	3-20
3-6.	RAM Configuration (U83)	3-25
3-7.	ROM Select Logic	3-26
3-8.	Pod Control Port Bit Assignment	3-27
3-9.	Pod Interface Pinout	3-29
3-10.	DTIO #1 (Channels A, B)	3-32
3-11.	DTIO #2 (Channels C, D)	3-33
3-12.	Floppy Controller Addressing	3-34
3-13.	Floppy Drive Control Latch Outputs	3-34
3-14.	Power Supply Pinout	3-35
3-15.	Ribbon Cable Connections	3-43
3-16.	Display Characters	3-39
3-17.	Control Characters	3-41
3-18.	Key Values	3-43
3-19.	Probe I/O Module Interface Address Map	3-46
3-20.	Voltage Threshold Levels	3-48
3-21.	Typical Probe Pulser Amplitude	3-61
3-22.	Pulser Pulse Width	3-62
3-23.	Custom Chip Pin Description	3-76
3-24.	U18 Truth Table	3-77
3-25.	VHI and VLO for TTL and CMOS Logic Levels	3-80
3-26.	Dip-Clip and Calibration Module Configuration Codes	3-82
3-27.	Connector Codes	3-83
3-28.	Logic Levels of NDRV and PDRV	3-84
4-1.	Required Tools and Test Equipment	4-4
4-2.	Fuse Part Numbers	4-8
4-3.	Monitor Alignment Program	4-33
4-4.	Power-Up Self Test Responses	4-39
4-5.	Display Self Test	4-43
4-6.	SMT Rework Tools and Supplies	4-65
4-7.	RAM Configuration (U83)	4-68
4-8.	Floppy Disk Jumper Settings	4-69
4-9.	Clip and Flying Lead Module Configuration Switch Settings	4-72

List of Tables

TABLE	TITLE	PAGE
5-1.	Model Configurations	5-5
5-2.	9100 Series Final Assembly	5-6
5-3.	A1 Main PCA	5-17
5-4.	A2 Display Interface PCA	5-20
5-5.	A4 Video Controller PCA	5-22
5-6.	A5 Probe PCA	5-24
5-7.	A6 Clock Module PCA	5-26
5-8.	A7 I/O Module (Main) PCA	5-28
5-9.	A8 I/O Module (Top) PCA	5-30
5-10.	A9 Probe I/O PCA	5-32
5-11.	A10 Multi-Function Interface PCA	5-35
5-12.	A11 I/O Connector PCA	5-37
5-13.	A12 Half-Width Clip Module	5-39
5-14.	A13 Full-Width Clip Module	5-40
5-15.	A14 Calibration Module	5-41
5-16.	A15 Flying Lead Module	5-42
5-17.	A16 512K RAM Module	5-43
5-18.	A19 Monochrome Monitor	5-45
5-19.	Parallel I/O Module (9100A-003)	5-46
5-20.	Programmer's Station, Mono (9100A-004)	5-50
5-21.	Programmer's Station, Color (9100A-005)	5-53
5-22.	Real-Time Clock PCA (9100A-008)	5-56
5-23.	Video, Monochrome (9100A-009)	5-58
5-24.	Video, Color (9100A-011)	5-61
5-25.	Programmer's Keyboard (9100A-013)	5-63

LIST OF FIGURES

FIGURE	TITLE	PAGE
	Frontispiece	
2-1.	Side Features	2-4
2-2.	Rear Panel Features	2-5
3-1.	9100A Block Diagram	3-6
3-2.	9105A Block Diagram	3-7
3-3.	68000 Pin Assignments	3-15
3-4.	Vacuum Fluorescent Display	3-37
3-5.	Probe I/O Interface Block Diagram	3-44
3-6.	-VDRV Voltage Regulator Simplified Schematic	3-54
3-7.	Status Register Bit Breakdown	3-56
3-8.	Control Register Bit Breakdown	3-57
3-9.	Probe/Pulser Functional Block Diagram	3-60
3-10.	Probe Speed Specifications	3-60
3-11.	Probe Response Timing Specifications	3-61
3-12.	Video Display Address Mapping	3-65
3-13.	Video Character Data Format	3-66
3-14.	I/O Module Functional Block Diagram	3-69
3-15.	I/O Module Address Decoding Summary	3-71
3-16.	Address Decoding Example	3-72
3-17.	Hot-Bit Decoding Examples	3-73
3-18.	Bus Interface Timing Diagram	3-74
3-19.	I/O Module Command Register	3-79
3-20.	Custom Chip Voltage Level Detection	3-80
3-21.	Chip Channel Input/Pattern Drive Output Schematic	3-84
4-1.	9100A System	4-10
4-2.	9105A System	4-11
4-3.	Disassembly Details	4-15
4-4.	Monitor Rear Panel	4-20
4-5.	Power Supply Lead Connections	4-23
4-6.	Display PCA	4-27
4-7.	External Display Adjustment Locations	4-35
4-8.	Oscilloscope Use in Probe Compensation	4-47
4-9.	Probe Compensation Square Wave	4-48
4-10.	Small Outline Integrated Circuit (SOIC)	4-55
4-11.	Plastic Leaded Chip Carrier (PLCC)	4-55
4-12.	Butt-Soldered DIP	4-56
4-13.	Small Outline Transistor (SOT)	4-56
4-14.	Metal Electrode Face (MELF)	4-56
4-15.	Chip Component	4-57
4-16.	Surface Mount Footprint	4-57

List of Figures

FIGURE	TITLE	PAGE
4-17.	PLCC Lead Index	4-59
4-18.	SOIC Lead Index	4-59
4-19.	Chip Soldering	4-63
4-20.	PLCC Soldering	4-63
4-21.	SOIC Soldering	4-64
5-1.	9100 Series Final Assembly	5-8
5-3.	A1 Main PCA	5-19
5-3.	A2 Display Interface PCA	5-21
5-4.	A4 Video Controller PCA	5-23
5-5.	A5 Probe PCA	5-25
5-6.	A6 Clock Module PCA	5-27
5-7.	A7 I/O Module (Main) PCA	5-29
5-8.	A8 I/O Module (Top) PCA	5-31
5-9.	A9 Probe I/O PCA	5-34
5-10.	A10 Multi-Function Interface PCA	5-36
5-11.	A11 I/O Connector PCA	5-38
5-12.	A16 512K RAM Module	5-44
5-13.	Parallel I/O Module (9100A-003)	5-47
5-14.	Programmer's Station, Mono (9100A-004)	5-51
5-15.	Programmer's Station, Color (9100A-005)	5-54
5-16.	Real-Time Clock PCA (9100A-008)	5-57
5-17.	Video, Monochrome (9100A-009)	5-59
5-18.	Video, Color (9100A-011)	5-62
7-1.	A1 Main PCA	7-3
7-2.	A2 Display Interface PCA	7-7
7-3.	A3 Keypad PCA	7-9
7-4.	A4 Video Controller PCA	7-10
7-5.	A5 Probe	7-12
7-6.	A6 Clock Module PCA	7-13
7-7.	A7 I/O Module (Main) PCA	7-14
7-8.	A8 I/O Module (Top) PCA	7-16
7-9.	A9 Probe I/O PCA	7-17
7-10.	A10 Multi-Function Interface PCA	7-19
7-11.	A11 I/O Connector PCA	7-20
7-12.	A12 DIP Clip Module (Half)	7-21
7-13.	A13 DIP Clip Module (Full)	7-22
7-14.	A14 Calibration Module PCA	7-23
7-15.	A16 512K RAM Module	7-24
7-16.	A19 Monochrome Monitor, Block Diagram	7-25
7-17.	-013 Programmer's Keyboard, Block Diagram	7-25
7-18.	Interconnect Diagram, 9100A	7-26
7-19.	Interconnect Diagram, 9105A	7-27

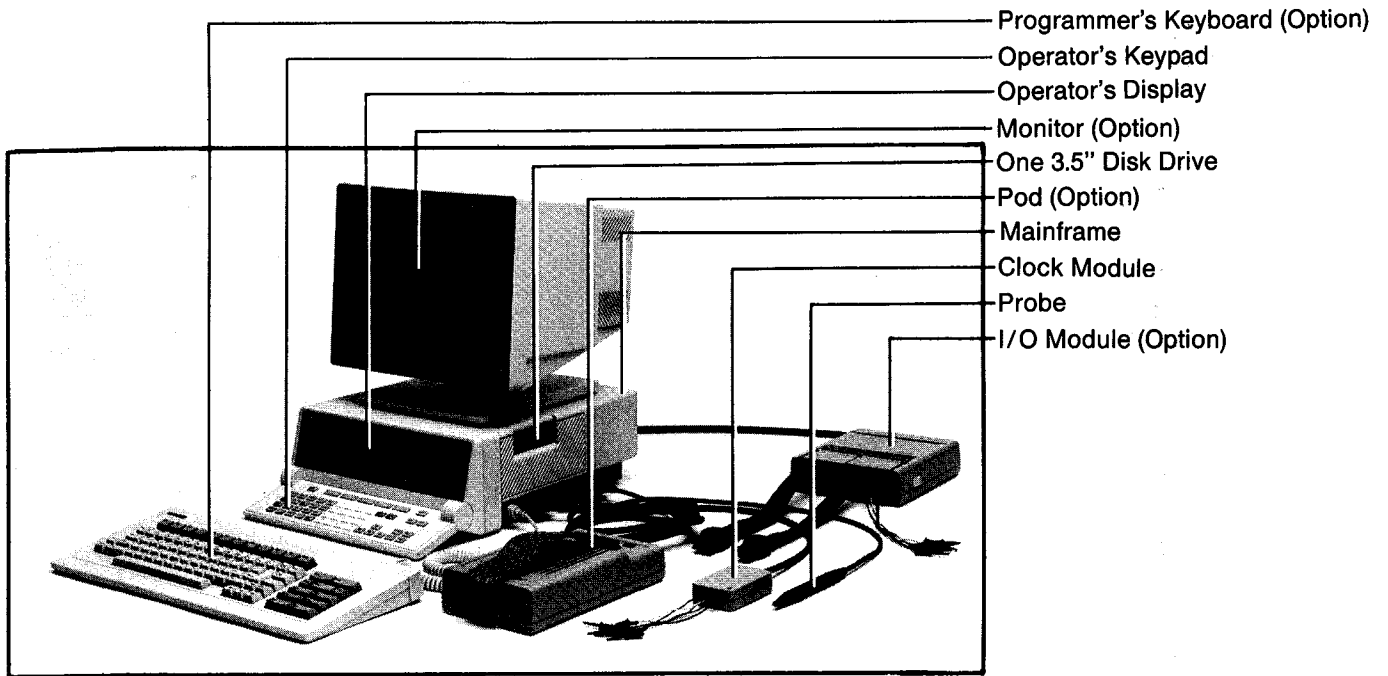

9100A System

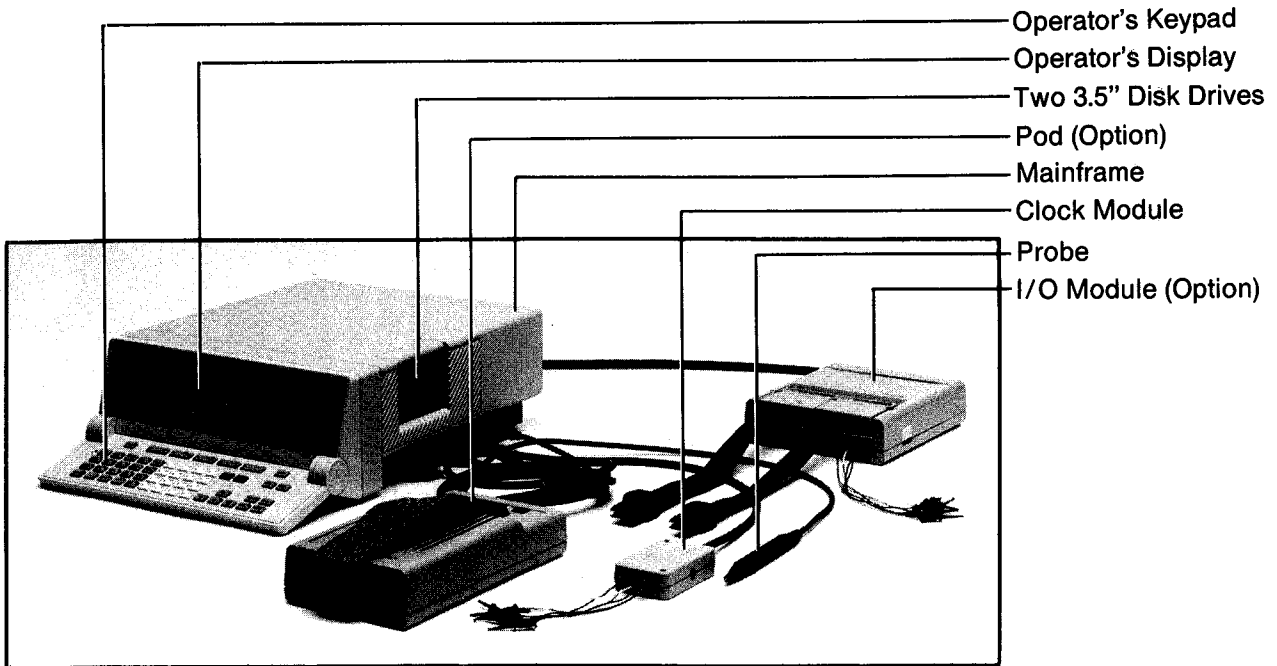

9105A System

Section 2
General Information

CONTENTS

Description	2-3
Power Requirements	2-3
External Connections	2-3
System Components	2-6
9100A System	2-6
9105A System	2-6
Options	2-6
Accessories	2-7
Interface Pods	2-7
Required Test Equipment	2-7
Shipping Information	2-7
Service Information	2-7
Specifications	2-10

DESCRIPTION

Information brought together in this section serves as a one-source reference for servicing the 9100A, 9105A, and related options. The 9100A/9105A instruments are fully described elsewhere in the manual set. Specifically, Getting Started and the Technical User's Manual can be consulted for hardware and capabilities information.

Power Requirements

Power requirements for the 9100A/9105A are presented in Table 2-1. The 9100A/9105A mainframe uses a maximum of 150 watts. In addition, the Monitor uses 50 watts maximum.

Table 2-1. Power Requirements

VOLTAGE SWITCH SETTING	LINE VOLTAGE RANGE	FREQUENCY	FUSE
110V	90-130V ac	47 to 440 Hz	2A Slow Blow
220V	180-264V ac	47 to 63 Hz	1A Slow Blow

External Connections

Servicing the 9100A/9105A may require disconnection of system components. For ease of reassembly, full connection information is presented here. Figure 2-1 identifies connections and other features found along the right side of either instrument. Figure 2-2 shows rear panel features.

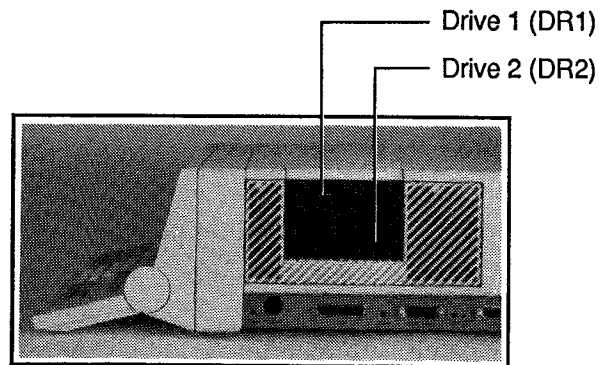
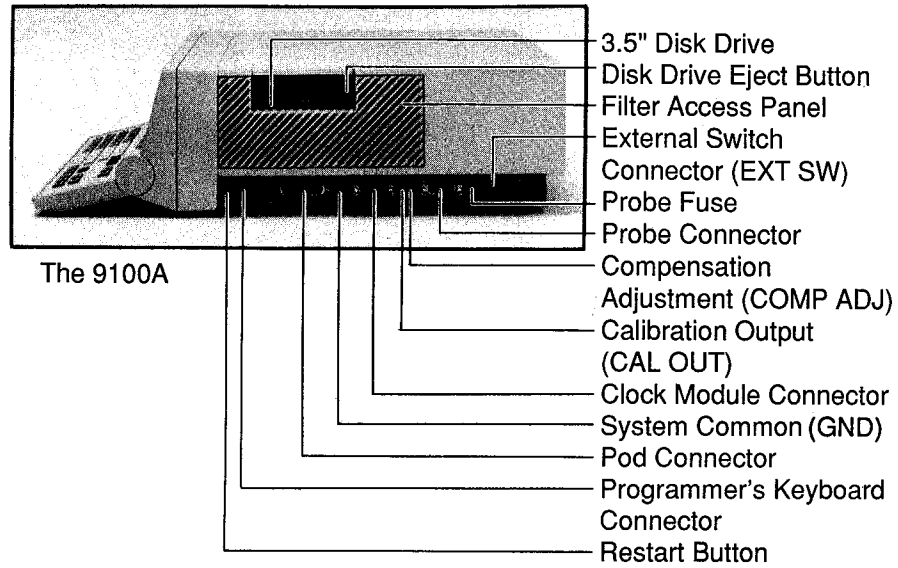

The 9105A, showing its different disk drive arrangement.

Figure 2-1. Side Features

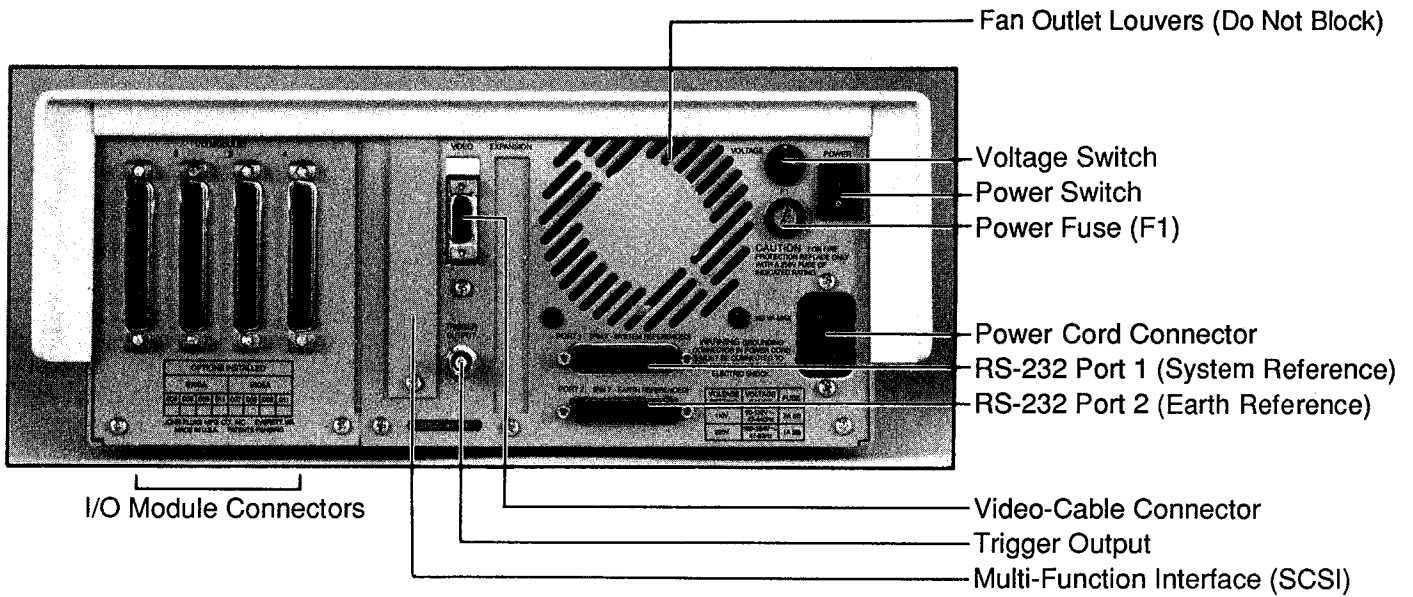

Figure 2-2. Rear Panel Features

2/General Information

SYSTEM COMPONENTS

Theories of operation, maintenance instructions, and schematic diagrams in this manual cover all 9100A/9105A system components. Refer to other manuals in the 9100A/9105A manual set for complete descriptions and usage instructions. The Getting Started manual provides a good overview of system components. These are listed and categorized in the following paragraphs, with references to coverage within this manual.

9100A Systems

The 9100A Digital Test System constitutes the mainframe, probe, and clock module documented in this manual.

The 9100/SYS Digital Test Programming System includes 9100A Test System components, along with the 9100A-003 Parallel I/O Module, the 9100A-004 Programmer's Station, and the Y9100A-DCS DIP Clip Set accessory described in this manual.

9105A System

The 9105A Test Station includes the mainframe, probe, and clock module described in this manual.

Options

The 9100A-004 Programmer's Station applies to the 9100A only. Its monochrome monitor, monochrome video controller, and keyboard are documented in this manual.

The 9100A-005 Programmer's Station is also available for the 9100A only and provides the color video controller and keyboard described in this manual.

Option 9105A-008, Real-Time Clock and Option 9105A-007, 512K Expansion Memory, are available for the 9105A only and are documented in this manual.

Finally, the following options are available for either the 9100A or the 9105A and are separately documented in this manual:

- o Parallel I/O Module, Option 9100A-003, includes a Y9100A-20L Flying Lead Module and a Calibration Module.
- o Video (Monochrome), Option 9100A-009, includes a Video Controller and a Monochrome Monitor.
- o Video Controller (Color), Option 9100A-011.
- o Keyboard, Option 9100A-013

Accessories

All hardware accessories for the 9100A/9105A are documented in this manual. These include:

- o Half-Width Clip Modules, Accessories Y9100A-14D, -14S, -16D, -16S, -18D, 20D, 20S, -24D, and 24S.
- o Full-Width Clip Modules, Accessories Y9100A-28D, -28S, and -40D.
- o Y9100A-DCS DIP Clip Set, including Y9100A-14D, -16D, -18D, -20D, -24D, -28D, and -40D.
- o Flying Lead Module, Accessory Y9100A-20L

Interface Pods

Interface pods can be used with a wide range of microprocessors. Each pod is documented in its own manual, none of which are included with 9100A/9105A Manual Set. No pod information is provided in this service manual.

REQUIRED TEST EQUIPMENT

Tools and test equipment required in servicing the 9100A or 9105A are listed in Table 2-2.

SHIPPING INFORMATION

When you receive the instrument, inspect the shipping container for any possible shipping damage. Special instructions for inspection and claims are included on the shipping container.

If it is necessary to reship the instrument, use the original container. If the original container is not available, a new one can be obtained from the John Fluke Manufacturing Co., Inc. upon request.

SERVICE INFORMATION

The 9100A/9105A is warranted for a period of 90 days upon delivery to the original purchaser. The warranty is located in the front of this manual, following the title page.

Factory calibration and service for each Fluke product is available at various locations worldwide. A complete list of these service centers is given in the appendices of this manual. If requested, an estimate will be provided to the customer before any work is begun on an instrument whose warranty period has expired.

Maintenance plans are available to maintain the 9100A/9105A at your site, to supplement the normal warranty period, or to do both. For specific information, contact your nearest Fluke Technical Service Center or Sales Representative.

2/General Information

Table 2-2. Required Tools and Test Equipment

EQUIPMENT REQUIRED FOR GENERAL SERVICING		
EQUIPMENT	RECOMMENDED MODEL	FUNCTION/COMMENTS
Digital Multimeter	Fluke Model 77	
Oscilloscope	Philips Model PM 3065 (or equivalent)	
Adjustment Tool	P/N 800540	
Flat Blade Screwdriver		1/8-inch (3 mm) blade
Flat Blade Screwdriver		1/4-inch (6 mm) blade
Phillips Screwdriver		#2, blade 4 inches (10 cm) or longer
Hex Driver		3/16-inch (5 mm)
Hex Driver		5/16-inch (8 mm)
Wrench		3/16-inch (5 mm) or adjustable
REQUIRED EQUIPMENT FOR COMPONENT LEVEL REPAIR		
EQUIPMENT	RECOMMENDED MODEL	FUNCTION/COMMENTS
9100A Service Kit	P/N 818948	
Digital Test Station, with I/O Module	Fluke Model 9105A (or 9100A) with 9100A-003 Option	Runs programs supplied with Service Kit
68000 Interface Pod	Fluke Model 9000A-68000	Used with Service Kit
Surface Mount Repair tools		See Table 4-6

Table 2-2. Required Tools and Test Equipment (cont.)

REQUIRED EQUIPMENT FOR MONOCHROME MONITOR MAINTENANCE		
EQUIPMENT	RECOMMENDED MODEL	FUNCTION/COMMENTS
Hex Adjustment Tool	P/N 572321	Horizontal Size/Linearity
Alignment Template	P/N 777144	Use with Monitor Pattern Program
Long-Nose Pliers		
Flat-Blade Screwdriver		1/4-inch (6 mm) blade, plastic handle with blade at least 5 inches (12.5 cm) long.
Phillips Screwdriver		#2, plastic handle with blade at least 3 inches (7.5 cm) long.
Phillips Screwdriver		#2, non-magnetic tip blade, plastic handle, with blade at least 12 inches (30 cm) long, for crt replacement.
Torque Hex Driver		3/16-inch (5 mm).
Soft Pad (foam or quilted)		Approximately 8 x 10 inches (20 x 25 cm).
1 Megohm, 1W Resistor	P/N 109793	To discharge crt anode.
Clip Leads (2)		For connecting resistor to chassis and screwdriver shaft.
Safety Gloves		Mid-forearm length, soft leather.
Full Face Shield (preferred) or Safety Goggles		
Lab Smock with Zipper		Plastic zipper. Metal parts should not come in contact with the crt.

2/General Information

SPECIFICATIONS

Specifications for the 9100A/9105A are presented in Table 2-3.

Table 2-3. Specifications

ELECTRICAL SPECIFICATIONS

Probe

Input Threshold

Logic Level	TTL Voltage	CMOS Voltage	RS-232 Voltage
1	2.6 to 5.0V	3.7 to 5.0V	3.2 to 30V
1 or X	2.2 to 2.6V	3.3 to 3.7V	2.8 to 3.2V
X	1.0 to 2.2V	1.2 to 3.3V	-2.8 to 2.8V
X or 0	0.6 to 1.0V	0.8 to 1.2V	-3.2 to -2.8V
0	0.0 to 0.6V	0.0 to 0.8V	-30 to -3.2V

Input Impedance 70 kilohm shunted by less than 33 pF

Data Timing for Synchronous Measurements

Maximum frequency	40 MHz
Minimum pulse width	
High or low	12.5 ns
3-state	20.0 ns
Setup times	
Data to Clock	5 ns
Start, Stop, or Enable to Clock	10 ns
Hold time	
Clock to Enable	10 ns
Clock to Start or Stop	0 ns

Data Timing for Asynchronous Measurements

Maximum frequency	40 MHz
Minimum pulse width	
High or low	12.5 ns
Invalid (X)	
TTL or CMOS	100 ns \pm 20 ns
RS-232	2000 ns \pm 400 ns

Table 2-3. Specifications (cont)

Transition Counting

Maximum frequency	at least 40 MHz
Maximum count	16777215 (+overflow)
Maximum stop count	65535 clocks

Frequency Measurement

Maximum frequency	at least 40 MHz
Resolution	20 Hz
Accuracy	± 250 ppm ± 20 Hz

Output Pulser

High	>3.5V @200 mA for less than 10 us @ 1% duty cycle >4.0V @ 4 mA continuously
Low	<0.8V @ 200 mA for less than 10 us @ 1% duty cycle <0.4V @ 5 mA continuously

Clock Module

Input Thresholds (all lines)

1.6V ± 0.2 V

Input Impedance

50 kilohm shunted by less than 10 pF

Clock, Start, Stop, and Enable Input Speed

Maximum repetition rate	40 MHz
Minimum pulse width	12.5 ns

2/General Information

Table 2-3. Specifications (cont)

RS-232 Interfaces

One connector isolated (system-referenced), the other connector non-isolated (earth-referenced).

Baud rates	110, 134, 300, 600, 1200, 1800, 2400, 4800, 9600, 19200
Parity	Odd, even, or none
Data bits	5, 6, 7, or 8
Stop bits	1, 1.5, or 2
XON/XOFF (Ctrl-S/Ctrl-Q)	Disable/Enable
Clear-to-Send	Disable/Enable
New line	Carriage Return and Line Feed (CRLF) or Carriage Return (CR)

I/O Module

Data Output

Current (>10 ms)	± 200 mA $\pm 10\%$
Current (<10 ms)	± 2 A $\pm 10\%$
Pattern rate (one module driven)	Approximately 35 kHz
Pattern depth (one module driven during 10 ms high current pattern drive mode)	256 patterns
Maximum current (at $V_{out} \geq 2V$) (per pin, driving high)	275 mA
Maximum current (at $V_{out} \leq 0.8V$) (per pin, driving low)	150 mA

Table 2-3. Specifications (cont)

Input Thresholds

Logic Level	TTL Voltages	CMOS Voltages
1	2.6 to 5.0V	3.4 to 5.0V
1 or X	2.1 to 2.6V	2.9 to 3.4V
X	1.0 to 2.1V	1.2 to 2.9V
X or 0	0.6 to 1.0V	0.8 to 1.2V
0	0.0 to 0.6V	0.0 to 0.8V

Input Impedance 50 kilohm minimum, shunted by less than 80 pF

Clock, Start, Stop, and Enable Inputs

Logic Thresholds

Low 0.8V maximum
High 2.0V minimum

Input Current ± 1 uA

Input/Output Overvoltage Protection

± 15 V for one minute maximum, any pin, one at a time

Transition Counting

Maximum frequency at least 10 MHz
Maximum count (transition mode) 8388607 counts (+overflow)
Frequency accuracy (frequency mode) ± 250 ppm ± 2 Hz

Stop Counter

Maximum frequency 10 MHz
Maximum count 65535 clocks

Clock

Maximum frequency 10 MHz
Minimum pulse width 50 ns

Table 2-3. Specifications (cont)

Data Timing for Synchronous Measurements

Maximum frequency of clock
10 MHz

Maximum frequency of data
5 MHz

Data setup time 30 ns

Data hold time 30 ns

Minimum pulse width (data)
75 ns

Minimum pulse width 50 ns
(Start, Stop, Enable, Clock)

Start edge setup time 0 ns
(before clock edge, for
clock edge to be recognized)

Stop edge hold time 10 ns
(after clock edge, for clock
edge to be recognized)

Enable setup time 0 ns
(before clock edge, for clock
edge to be recognized)

Enable hold time 10 ns
(after clock edge, for clock
edge to be recognized)

Data Timing for Asynchronous Measurements

Maximum frequency 10 MHz

Minimum pulse width 50 ns
(high or low)

Minimum pulse width 150 ns
(3-state)

Data Compare Equal (DCE)

Minimum pulse width 75 ns
(Data and Enable)

Table 2-3. Specifications (cont)

GENERAL SPECIFICATIONS

Line Voltage 90 to 132V ac, 47 to 440 Hz
180 to 264V ac, 47 to 63 Hz

Power Consumption

Mainframe 150W maximum
Monitor 50W maximum

Safety

Designed to meet ANSI/UL 478, IEC 348, IEC 435, and CSA 556B standards.

PHYSICAL SPECIFICATIONS

Operating Temperature

5° to 27°C, 95% RH maximum (noncondensing)

27° to 40°C, RH decreasing linearly from 95% to 50%
(noncondensing)

Programmer's Station

24-line by 80-column crt monitor with video controller installed in mainframe. 87-key keyboard with separate cursor control, and hardkey and softkey function keys.

Storage/Shipping Temperature

-20° to 60°C, 8% to 80% RH (noncondensing). Micro-floppy media limited from 5° to 60°C, 8% to 80% RH (noncondensing).

Size

Mainframe 14.0 x 34.3 x 50.8 cm (H x W x D)
(5.5 x 13.5 x 20.0 in)

Monitor 30.5 x 33.5 x 33.0 cm (H x W x D)
(12.0 x 13.2 x 13.0 in)

ASCII Keyboard 5.1 x 21.2 x 47.2 cm (H x W x D)
(2.0 x 8.3 x 18.6)

Weight

Mainframe 8.3 kg (18.2 lb)
Monitor 11.1 kg (24.5 lb)
ASCII Keyboard 1.6 kg (3.5 lb)

CONTENTS

Overview	3-5
Main PCA	3-5
RS-232 Ports	3-5
Micro Floppy Disk System	3-5
Hard Disk System	3-6
Power Supply	3-6
Operator's Display	3-6
Operator's Keypad	3-6
Probe/Pulser	3-6
Clock Module	3-6
Monitor	3-6
Programmer's Keyboard	3-7
I/O Module	3-7
Main PCA (MC68000 Microprocessor)	3-7
Overview	3-7
Signal and Pin Description	3-7
Signal Description	3-7
Signal Organization	3-13
Address/Data Bus Operation	3-14
Address Bus	3-14
Data Bus	3-14
Bus Operation During Data Transfer	3-14
The Read Cycle	3-15
The Write Cycle	3-15
The Read-Modify-Write Cycle	3-15
Bus Arbitration	3-16
Bus Error and Halt	3-16
Privilege Modes	3-17
Exception Processing	3-17
Interrupts	3-18
Parity Error Interrupt	3-19
Floppy Data Interrupt	3-20
DTIO #1 Interrupt	3-20
DTIO #2 Interrupt	3-21
MFI Card Interrupt 2	3-21
Expansion Card Interrupt 2	3-21

Floppy Controller Interrupt	3-21
Probe Interrupt	3-21
I/O Overcurrent Interrupt	3-22
Pod Interrupt and Pod Power Fail Interrupt	3-22
I/O Module General Interrupt	3-22
I/O Module Data Compare Equal Interrupt	3-22
Video Controller Interrupt	3-22
Self-Vectored Interrupt	3-22
No Interrupt	3-22
Asynchronous Execution	3-23
Reset Signal Description and Generation	3-23
Address Decoding and DTACK	3-24
RAM	3-24
RAM Configuration	3-24
RAM Timing	3-25
RAM Refresh	3-25
RAM Parity	3-26
ROM	3-26
Pod Interface	3-27
DUART-Timer-I/O	3-30
Microfloppy Disk System	3-33
Disk Drive	3-33
Floppy Drive Controller	3-33
Interrupts	3-35
Hard Disk System	3-35
Power Supply	3-35
Operator's Display	3-35
Vacuum-Fluorescent Display (VFD)	3-35
Displayable Characters	3-38
Annunciators	3-42
Operator's Keypad	3-42
Probe I/O Module Interface	3-43
Overview	3-43
Probe I/O Module Interface Addressing	3-46
Probe Interface	3-46
Probe Data Input	3-47
Threshold Voltage Calculation	3-47
Probe Operation Voltages	3-49
Fuse Blown Detection	3-49
Probe Light Drive and Control	3-49
External 16-bit Counter	3-49
Clock Module Interface	3-50
Custom Delay Chip	3-50
Custom Logic Chip	3-51
Stop Counter	3-53

I/O Module Interface Connector	3-53
I/O Module -VDRV Voltage Regulator	3-54
I/O Module Overcurrent Detection	3-55
Miscellaneous Functional Blocks	3-55
Sync Pulse Isolation	3-55
Footswitch Connector	3-56
Data Bus Buffers	3-56
Status Register	3-56
Control Register	3-57
I/O Connector Interface	3-57
Overview	3-57
Power Supplies	3-58
I/O Module Connector PCA Contents	3-58
Probe/Pulser	3-59
Overview	3-59
Probe	3-59
Probe Tip Input	3-59
Common Ground Clip	3-61
Pulser	3-61
Level Indicators	3-62
Logic Level Modes	3-62
Level Indicator Operation	3-62
Push Button Switch	3-62
Clock Module	3-63
Overview	3-63
Clock Module Operation	3-63
Clock Module Speed	3-63
Multi-Function Interface	3-63
Overview	3-63
Addresses	3-64
Clock	3-64
SCSI	3-64
Video	3-64
Video Controller	3-65
Video RAM	3-65
Video Output	3-67
Monitor	3-67
Programmer's Keyboard	3-67
I/O Module	3-68
I/O Module Overview	3-68
Bus Interface Functional Block	3-70
Overview	3-70
Addressing	3-70
Custom Chip Selection	3-73
Custom Chip Functional Block	3-75

Clock and Enable Mux Functional Block	3-75
Clock and Enable Mux Operation	3-75
Inputs	3-75
Outputs	3-77
General Control Latch Functional Block	3-77
Overview	3-77
Control Register	3-77
Data Comparison Inputs	3-78
Fuse Detection	3-78
Data Comparison and General Interrupts	3-78
The Data Compare Equal Interrupt	3-78
The I/O General Interrupt	3-78
Data Compare Equal Output Pin	3-78
Operation of General Control Latch Block	3-79
Threshold Voltage Generation	3-79
Multi-Detection and Interrupt	3-81
Fuse Blown Detection	3-81
Connector Code Functional Block	3-81
Connector Code Examples	3-83
Input Protection/FET Output Block	3-83
Overview	3-83
Input Protection Section Operation	3-83
FET Output Section Operation	3-83
I/O Module Top PCA Functional Block	3-85
DIP Clip and Calibration Module Functional Block	3-85
Overview of the Clip and Calibration Modules	3-85
Clip and Calibration Module Operation	3-86
Half Width Clip Module	3-86
Full-Width Clip Module	3-86
Calibration Module	3-86

OVERVIEW

This overview of the Fluke 9100A/9105A explains the general relationships of the unit blocks contained in the 9100A Block Diagram, Figure 3-1, and the 9105A Block Diagram, Figure 3-2. Wherever a block performs the same function for both instruments, an identical block name is used for ease of reference later in this section.

Main PCA

The Main Printed Circuit Assembly contains the following functional blocks:

- o 68000 Microprocessor
- o Read/Write (RAM) Memory
- o Read-Only ROM Memory,
- o Floppy Disk Drive Controller
- o Pod Interface
- o Power Supplies for the RS-232 ports, operator's display, and video.

The PCA contains the interfaces for expansion cards, serial ports, and the keyboards. There are connections for the Floppy Disk Drive, the Monitor, the Hard Disk Controller, the Probe I/O Module Interface, the microprocessor Pod, and the switching Power Supply.

RS-232 Ports

Two RS-232-C serial ports are available on the 9100A. These ports allow data transfer to and from the tester. One is system-referenced (isolated from earth) and is used with the UUT. The other is a non-isolated port and is used for connection to another tester, computer, or printer. The Serial Port connectors are located at the rear of the Chassis.

Micro Floppy Disk System

The Floppy Disk System uses 3.5-inch double-sided, double-density disks. A disk has a formatted capacity of 640K bytes. The 9100A uses one disk drive, and the 9105A uses two disk drives. The floppy drive is connected through J14 on the Main PCA.

3/Theory of Operation

Hard Disk System

The 9100A contains a 20M byte, 3.5-inch Hard Disk to store the operating software, user programs, and data. The Hard Disk interfaces to the Hard Disk Controller via the ST412 interface standard. The Hard Disk Controller interfaces to the Multi-Function Interface (MFI) PCA, which implements the SCSI interface standard. The MFI PCA, which plugs into the Main PCA at J6, also includes the battery-powered back-up clock for the 9100A.

Power Supply

The Power Supply for the 9100A/9105A is an OEM (original equipment manufacturer) switching power supply. Input voltage is switchable for either 90 to 132V ac or 180 to 264V ac operation. This functional block supplies one +5V, one -5V, and two +12V outputs to the system.

Operator's Display

The Operator's Display is a vacuum-fluorescent display, 254 pixels wide by 26 pixels deep, allowing for 42 characters per line. The Display is located above the Operator's Keypad on the Main Chassis. The Display Interface PCA is connected to J11 on the Main PCA.

Operator's Keypad

The Operator Keypad is a part of the Main Chassis unit that, when folded down, faces the operator. It is connected to J2 on the Display Interface PCA. It contains all of the keys needed by the operator to run pre-programmed tests used in the immediate troubleshooting mode.

Probe/Pulser

The Probe is a single-point, hand-held instrument that can measure signals up to 40 MHz. The Probe also acts as a pulser. The Probe is useful for portions of the board that cannot be accessed with the I/O Module or Pod. The Probe plugs into a connector on the side of the Chassis and is wired to J1 on the Probe I/O PCA.

Clock Module

The Clock Module is an external unit connected to the Main Chassis through J3 on the Probe I/O PCA. The Clock Module provides connections to external clock signals for troubleshooting signals asynchronous to the UUT microprocessor.

Monitor

The Monitor displays programming information entered from the Programmer's Keyboard. The Monitor can also assume Operator Keypad functions by displaying procedural information. The Monitor is connected to a Video Controller Card, which is plugged into the Main PCA.

Programmer's Keyboard

The Programmer's Keyboard is used for program development. It is also available as an option for data input to user programs. The Keyboard is connected to J10 on the Main PCA.

I/O Module

The I/O Module is an external unit used for data stimulus and response of up to 40 channels at one time. An assortment of clip modules is available for interface to the UUT. The 9100A can accommodate four I/O Modules at once, allowing for testing of 160 pins at a time. The 9100A has the capability to take CRCs (cyclic redundancy checks), measure frequency, take event counts, record logic levels, and drive output patterns on each pin. The I/O Modules plug into the I/O Connector PCA, which plugs into the Probe I/O PCA.

MAIN PCA (MC68000 MICROPROCESSOR)

Overview

The 9100A/9105A uses an MC68000 main processor(U32). The 16-bit MC68000 contains 17 32-bit registers, a 16-bit status register, and a 32-bit program counter. Of the 17 registers, 8 are data registers, 7 are address registers, and 2 registers are used as stack pointers. The MC68000 (U32) is located on the Main PCA of the mainframe.

The 68000 theory of operation covers the following:

- o Signal and pin description
- o Address/data operation
- o Modes of processing including interrupts
- o Asynchronous/synchronous execution
- o Reset signal description and generation

Signal and Pin Description

The following paragraphs describe the meaning of each signal produced by the 68000 and show how these signals are organized per function. A table helps to explain the mnemonics used on the schematic, and indicates whether the signal is an input or an output. Figure 3-3 shows the 68000 pin configuration for the 68-pin plastic leaded chip carrier (PLCC) package.

SIGNAL DESCRIPTION

Table 3-1 describes the 68000 microprocessor signals.

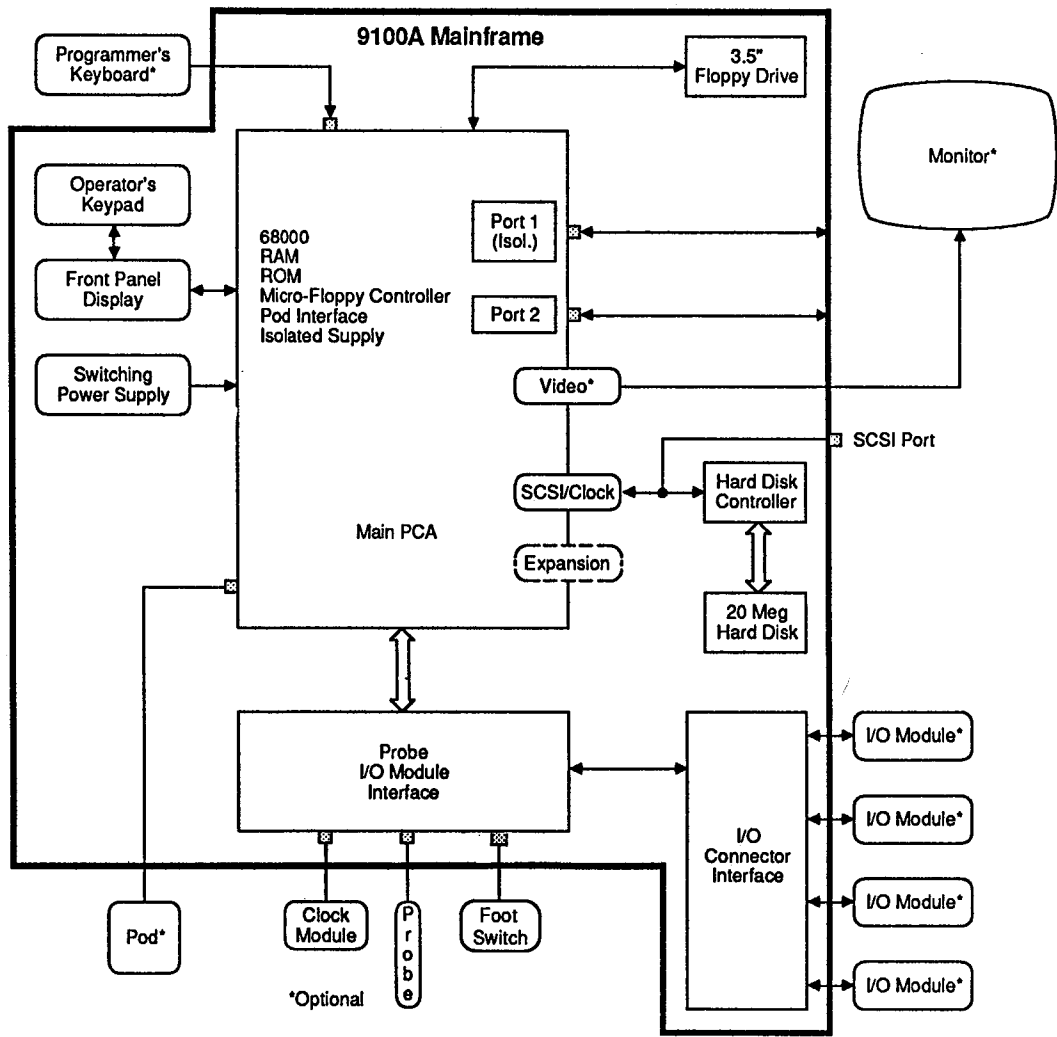

Figure 3-1. 9100A Block Diagram

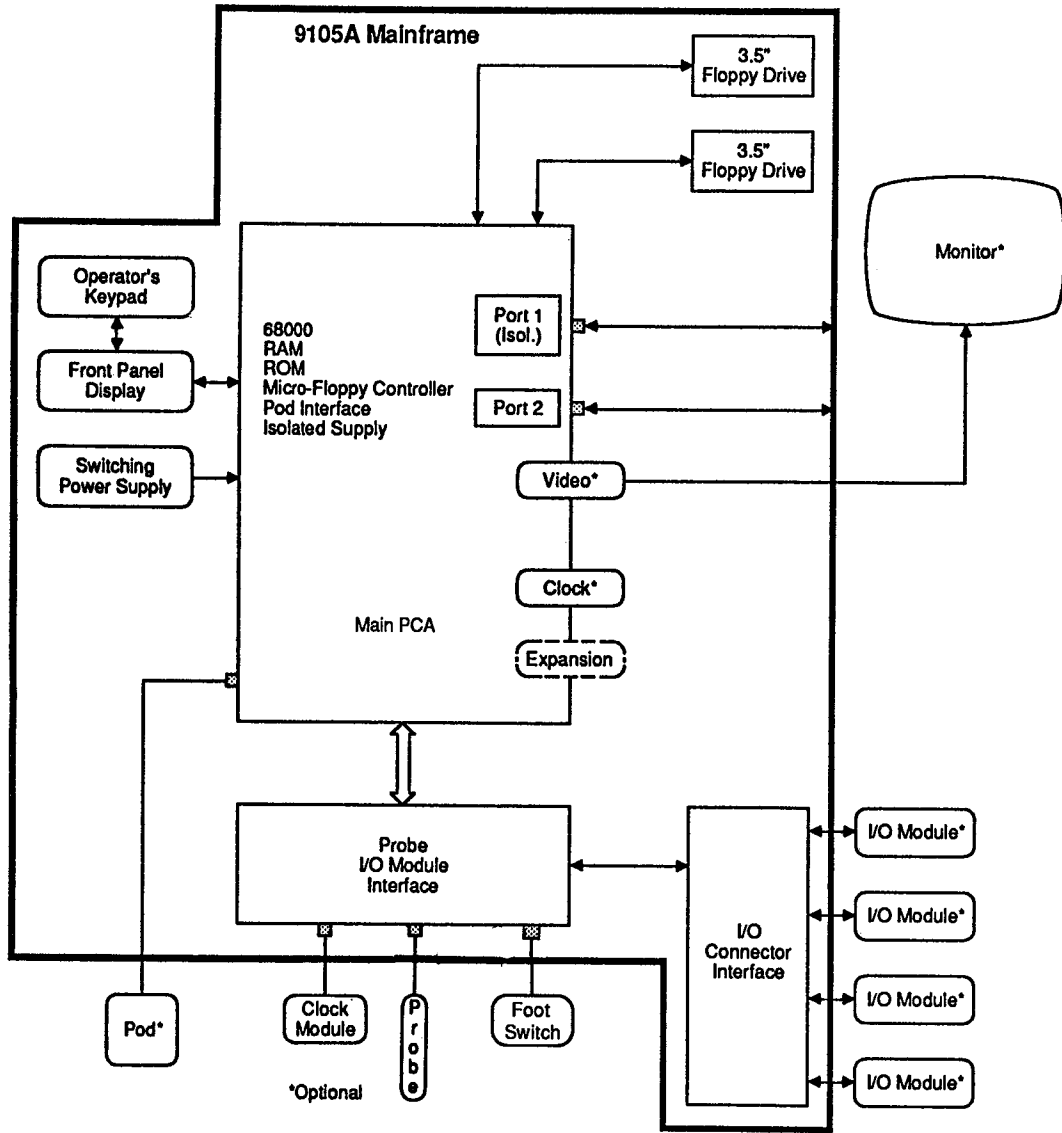

Figure 3-2. 9105A Block Diagram

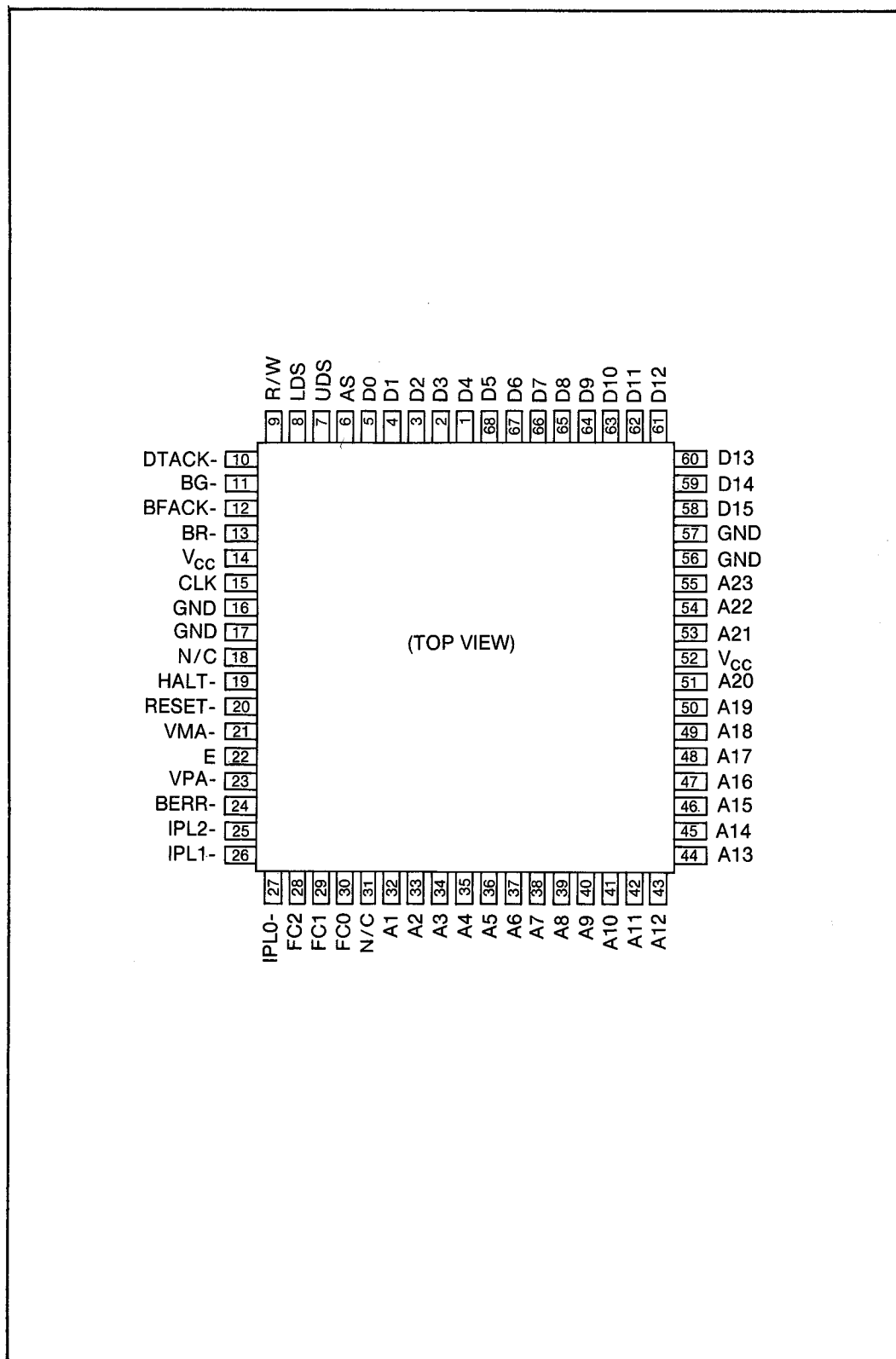

Figure 3-3. 68000 Pin Assignments

Table 3-1. Signal Descriptions

SIGNAL NAME	DESCRIPTION																																				
A1 through A23	Address Bus: 23 tri-state output lines, providing the bus address for all processor operations except interrupt vector fetch cycles. During interrupt acknowledge cycles, address lines A1, A2, and A3 indicate the interrupt level that is being serviced, while address lines A4 through A23 are set high. Address line A0 is used internally by the processor for byte operations.																																				
D0 through D15	Data Bus: 16-bit, bidirectional, tri-state data bus.																																				
FC0 through FC2	Function Code lines: tri-state outputs that indicate the state (user or supervisor) and type (program or data) of the current bus cycle. They are also used to indicate an acknowledge cycle as follows:																																				
	<table border="1"> <thead> <tr> <th>FC2</th> <th>FC1</th> <th>FC0</th> <th>CYCLE TYPE</th> </tr> </thead> <tbody> <tr> <td>0</td> <td>0</td> <td>0</td> <td>(undefined, reserved)</td> </tr> <tr> <td>0</td> <td>0</td> <td>1</td> <td>User data</td> </tr> <tr> <td>0</td> <td>1</td> <td>0</td> <td>User program</td> </tr> <tr> <td>0</td> <td>1</td> <td>1</td> <td>(undefined, reserved)</td> </tr> <tr> <td>1</td> <td>0</td> <td>0</td> <td>(undefined, reserved)</td> </tr> <tr> <td>1</td> <td>0</td> <td>1</td> <td>Supervisor data</td> </tr> <tr> <td>1</td> <td>1</td> <td>0</td> <td>Supervisor program</td> </tr> <tr> <td>1</td> <td>1</td> <td>1</td> <td>Interrupt acknowledge</td> </tr> </tbody> </table>	FC2	FC1	FC0	CYCLE TYPE	0	0	0	(undefined, reserved)	0	0	1	User data	0	1	0	User program	0	1	1	(undefined, reserved)	1	0	0	(undefined, reserved)	1	0	1	Supervisor data	1	1	0	Supervisor program	1	1	1	Interrupt acknowledge
FC2	FC1	FC0	CYCLE TYPE																																		
0	0	0	(undefined, reserved)																																		
0	0	1	User data																																		
0	1	0	User program																																		
0	1	1	(undefined, reserved)																																		
1	0	0	(undefined, reserved)																																		
1	0	1	Supervisor data																																		
1	1	0	Supervisor program																																		
1	1	1	Interrupt acknowledge																																		
AS-	Address Strobe-: a tri-state output that indicates that valid data is present on the address and function code lines and that a bus cycle is in progress.																																				
R/W-	Read/Write-: an output that indicates the direction that data is to be transferred on the data bus.																																				
UDS-, LDS-	Upper Data Strobe- and Lower Data Strobe-: outputs that indicate whether upper, lower, or both bytes are to be used for a data bus transaction. During an interrupt acknowledge cycle, both UDS- and LDS- are asserted, but only the lower byte is read.																																				
DTACK-	Data Transfer Acknowledge-: an input that indicates to the processor that the bus data transfer will be completed at the end of the current processor clock cycle. It is used to terminate the current bus cycle unless superseded by a bus error or a reset.																																				
BR-	Bus Request-: an input that indicates to the processor that some other device is requesting control of the bus.																																				

Table 3-1. Signal Descriptions (cont)

BG-	Bus Grant-: an output that indicates that the processor will relinquish control of the bus at the end of the current bus cycle.
BGACK-	Bus Grant Acknowledge-: an input that indicates that a device other than the processor has assumed bus control.
IPL0-, IPL1- IPL2-	Interrupt Priority Level-: inputs that indicate the encoded priority level of the interrupting device. Level 0 indicates no interrupt is pending, while level 7 is the highest priority interrupt.
BERR-	Bus Error Line: an input that indicates a problem with the current bus cycle. When BERR- is asserted with the HALT- line, the processor reruns the current bus cycle if the HALT- line is released first. If BERR- is asserted during reset vector acquisition, or for two consecutive bus cycles, the processor halts. If BERR- is asserted alone, it causes the processor to execute a non-maskable interrupt to the Bus Error Vector.
RESET-	Reset-: a bidirectional open collector line used to reset the state of the processor. It may also be used by the processor to reset the state of the external environment.
HALT-	Halt-: a bidirectional open collector line that is asserted when the processor stops due to an unrecoverable error sequence. This line can be pulled low during a bus cycle to stop the processor at the end of the cycle, to rerun the last bus cycle (when BERR- is low), or to reset the processor (when RESET- is low).
E	Enable: an output used to simulate a 6800-type processor clock for interface with 6800 family peripherals. This signal runs continuously and is derived by dividing the processor clock by ten. The duty cycle consists of six clock periods low and four clock periods high.
VPA-	Valid Peripheral Address: an input used to request 6800-type bus cycles. During interrupt acknowledge cycles, this line is used to request automatic vectoring.
VMA-	Valid Memory Address: an output used to enable 6800-type peripheral devices. VMA- indicates that the processor is synchronized to the Enable line and has placed a valid address on the address bus.
CLK	Clock: an input used to derive the clocks needed internally by the processor.

SIGNAL ORGANIZATION

The control signals of the 68000 can be grouped for the different functions. The function codes (FC0 through FC2) are the processor status signals that produce code sequences to indicate the mode (user or supervisor) and whether a data cycle or a program cycle is currently being executed. The code output is valid during an active address strobe (AS-). The code output is decoded externally to indicate interrupt acknowledge. The FC2 line is also used for address decode on the Multi-Function Interface PCA, the floppy controller chip, and the first 8K of RAM. This technique prevents user programs from accessing these areas.

The bus request (BR-), bus grant (BG-), and bus grant acknowledge (BGACK-) signals are used for bus arbitration control. These signals determine which component or peripheral controls the bus. The bus request input indicates that another device is requesting to become the bus master. The bus grant output then indicates to all other potential bus masters that the microprocessor will relinquish control at the end of this bus cycle. Once the other device has become the bus master, it returns the Bus Grant Acknowledge input to the microprocessor. These three bus arbitration control signals can be used by the Multi-Function Interface PCA to avoid bus contention.

Asynchronous bus control signals are Address Strobe (AS-), Read/Write (R/W-), Upper and Lower Data Strobes (UDS-, LDS-), and Data Transfer Acknowledge (DTACK-). The R/W- signal indicates the direction of data transfer on the data bus. When R/W- is high, data is being read from another functional block to the microprocessor. In the low state, data is being written to another functional block. The Upper and Lower Data Strobe signals are used in conjunction with the Read/Write signal to identify transfer of valid lower (D0 through D7) and/or upper (D8 through D15) data bytes. This data strobe control is defined in Table 3-2.

Table 3-2. Data Strobe Control

UDS-	LDS-	R/W-	UPPER D8-D15	LOWER D0-D7
High	High	-	none	none
Low	Low	Low	Write 8-15	Write 0-7
High	Low	Low	none	Write 0-7
Low	High	Low	Write 8-15	none
Low	Low	High	Read 8-15	Read 0-7
High	Low	High	none	Read 0-7
Low	High	High	Read 8-15	none

3/Theory of Operation

The Address Strobe (AS-) signifies that there is a valid address on the address bus. The Data Transfer Acknowledge (DTACK-) signal is an input signifying that data transfer is complete.

The System Control signals are Bus Error (BERR-), RESET-, and HALT-. The BERR- signal informs the microprocessor that there is a problem on the bus. The RESET- and HALT- signals reset or halt the 9100A/9105A system.

The 68000 uses three signal lines for peripheral control. The Enable (E), Valid Peripheral Address (VPA-), and Valid Memory Address (VMA-) allows for interfacing synchronous peripheral devices with the asynchronous 68000. The VPA- mode is not used in the 9100A/9105A system except for tests using the expansion connector on the Main PCA.

Address/Data Bus Operation

The address bus and the data bus are covered separately in the following discussion. For the address bus, size, contents, address ranges of the entire 9100A/9105A system are included. For the data bus, size and use are discussed.

ADDRESS BUS

The 23-bit address bus (A1 through A23) is used to access other functional blocks throughout the 9100A/9105A. If an interrupt occurs, address lines A1, A2, and A3 provide information about the type of interrupt, and the remaining lines are held high.

Table 3-3 shows ranges of memory available for various functional blocks. Actual addresses used within these ranges are defined under the appropriate functional block descriptions.

DATA BUS

The 16-bit data bus (D0 through D15) provides for bidirectional exchange of data between the microprocessor and an addressed functional block. Data lines D0 through D7 supply the vector number to the processor during an interrupt acknowledge cycle.

Bus Operation During Data Transfer

Three different types of cycles occur during data transfer: read, write, and read-modify-write. The following paragraphs explain the sequence of events during these cycles.

Table 3-3. Address Ranges

HEX ADDRESS	USE
000000 - 07FFFF	ROM
080000 - 08FFFF	Floppy Control *
090000 - 093FFF	DTIO #1: Keypad/Display, RS-232 Port #1
	DTIO #2: ASCII Keyboard, RS-232 Port #2
094000 - 097FFF	Interrupt Vector (Read)
098000 - 09BFFF	Parity Error Latch (Read)
09C000 - 09FFFF	Pod Interface
0A0000 - 0AFFFF	Expansion Card Slot
0B0000 - 0BFFFF	Multi-Function Interface Card Slot
0C0000 - 0CFFFF	Logic Probe Circuitry
0D0000 - 0DFFFF	I/O Modules
0E0000 - 0EFFFF	Video RAM
0F0000 - 0FFFFF	Video Controller Chip
100000 - BFFFFF	unassigned
C00000 - FFFFFF	RAM **

* Supervisor Mode only

** C00000 - C01FFF accessible in Supervisor Mode only

THE READ CYCLE

The read cycle involves transmitting bytes of data from a peripheral or from a memory space to the 68000 processor. If a word is read, both the upper data strobe and lower data strobe are active. In the case of a byte operation, an internal A0 bit determines which byte to be read. The 68000 issues the required data strobe for that byte. When the lower data strobe (D00 through D07) is issued, the A0 bit equals 1; when the upper data strobe (D08 through D15) is issued, A0 equals 0.

THE WRITE CYCLE

The write cycle process involves the 68000 sending bytes of data to a peripheral or a memory location. As in the read cycle, the processor uses an internal A0 bit to determine if the high or low byte is written to, and the processor sends the required strobe signal. Both data strobes are active during a word write cycle.

THE READ-MODIFY-WRITE CYCLE

During the read-modify-write cycle, the 68000 performs a read, modifies the data internally, and writes the data to the original address. This cycle is used to let multiple processors communicate, and the address strobe is active throughout the cycle.

3/Theory of Operation

Bus Arbitration

The bus arbitration process is required to switch bus control from the 68000 to another device. First, the device sends a Bus Request Signal (BR-) to the microprocessor. The 68000 sends back a Bus Grant (BG-) signal at the end of the current bus cycle. To protect against noise interfering with bus arbitration, the microprocessor continues to process instructions when the BR- signal goes inactive and a BGACK- is not received. After receiving a BR- signal, the 68000 issues a BG- signal and an Address Strobe (AS-). The AS- signal indicates that a bus cycle is in progress. The BG- and AS- signals are not issued at the same moment; the BG- signal is delayed until the AS- signal is issued. When the device requesting the bus receives a BG-, the AS-, DTACK-, and BGACK- must be inactive before it sends a BGACK-. The device remains in control until it inactivates the BGACK- signal, which should be done only at the completion of the bus cycle(s).

A bus request can be initiated from any assembly attached to either the MFI or expansion connector, but not directly from the mainframe. The Main PCA does provide a priority encoding circuit that accepts a bus request (BR) and outputs a bus grant (BG). This circuit, composed of sections of U64 and U65, latches upon receipt of a bus request to ensure that the bus grant is output to the requesting device.

Bus Error and Halt

The 68000 transfers data asynchronously. That is, any device desiring to communicate with the microprocessor does so by handshake. If for some reason a handshake is not completed within seven microseconds, the hardware generates a Bus Error (BERR-) signal at U32-24. With BERR- active, the data and address busses are "off", and the current bus cycle is terminated. When the BERR- goes from active to inactive, several processes occur. The microprocessor stacks the contents of the program counter, the status register, and the error information. Next, a vector table address is read, and a software bus error handler routine from that address is then executed. Refer to Exception Processing later in this description for more information.

The BERR- acts similarly to a non-maskable interrupt, except that the microprocessor stores extra data on the stack. Bus errors can be used to detect the absence of accessories and options during initialization. The BERR- signal is generated by U40 using the enable (E) signal from J4.

The HALT- signal on U32-19 halts the microprocessor (after the current bus cycle) with a continuous active low. A continuous active high on this pin allows the 68000 to run.

If software tries to address a space with no valid memory, U40 asserts a bus error after six E clock periods. At any time, a write command to ROM also generates a bus error.

Privilege Modes

The following paragraphs explain activities of the 68000 that are not related to normal operation. The microprocessor exists in one of three modes: normal, exception, or halted. Exception processing and the 9100A/9105A system interrupts are covered. The normal situation allows for executing instructions, memory read and/or write, and storing results. A stop instruction stops the 68000 and is not related to a halt instruction.

Two types of privilege modes exist within the 68000: the supervisor mode and the user mode. The supervisor mode has higher priority than the user mode. The S-bit of the status register determines the mode in which the microprocessor operates. A 1 in the S-bit designates the supervisor mode, and all exception processing is performed in this state. All operations that require stacking during exception processing use the supervisor stack pointer.

The user mode is the lower of the two privilege modes, with 0 in the S-bit of the status register. Most instructions are executable (as in the supervisor mode) except for the stop and reset instructions. In the user mode the system stack pointer or address register 7 use the user stack pointer. To change from user to supervisor mode during the executing of instructions requires a change from normal to exception processing. To make this change the current status of the S-bit is saved, and the S-bit is forced to a 1. The set S-bit allows the microprocessor to resume the execution of instructions to process the exception in the supervisory mode.

Exception Processing

The 68000 categorizes resets, traps, interrupts, and bus errors as exceptions. Exceptions can be generated by either internal (software) or external (hardware) causes. All exceptions are assigned a number (0 through 255 decimal or 0 through FF hex). All exceptions are handled through a non-relocatable Exception Vector Table located at address 000000 through 0003FF. Each vector consists of four address bytes containing the exception handling routine address.

The externally generated exceptions are Reset, Bus Error, and Interrupt, all discussed in Table 3-1, Signal Descriptions. The internally generated exceptions can occur from program control operations such as trap (TRAP), trap on overflow (TRAPV), check data against upper bounds (CHK), divide (DIV), and trace (TRACE). In addition, software errors such as illegal instructions, word fetches from odd addresses, and privilege violations can cause exceptions. The internally generated exceptions act like non-maskable interrupts.

3/Theory of Operation

INTERRUPTS

The 9100A/9105A system uses 15 different interrupts allowing hardware and software to stop the 68000 operation and identify an error or specific condition. The interrupts are prioritized as follows according to their importance:

- o The Parity Error Interrupt (I15) is level 7, which is non-maskable (NMI).
- o All level 6 and lower levels are software maskable by level.
- o Levels 7 through 2 are each used by only one interrupt.
- o The level 1 interrupt is shared by several different interrupts. The interrupts within level 1 have priorities to prevent simultaneous requests.
- o Level 0 indicates no interrupt is pending.

Pending interrupts are detected between instructions. An interrupt is acknowledged and the service routine started only if the pending interrupt has a higher priority than the current processor priority. When an interrupt is acknowledged, the hardware places a vector value on the data bus. This vector points to a memory location where the address of the interrupt routine is stored. Interrupts can be polled by reading the interrupt vector at byte location 094001. An interrupt request must be reset by the interrupt acknowledging routine. Individual interrupt descriptions in the following paragraphs provide more details.

A list of hardware generated exceptions and their vectors is shown in Table 3-4. These exception vectors are listed by priority with the top priority vector listed first. The maximum amount of vectors is 256. The vectors with priority levels 1 to 7 (refer to Table 3-4) are hardware generated at an interrupt acknowledge. Bus Error and Reset (Level *) behave differently; these exceptions always go to a predetermined address.

The interrupt circuitry located on the Main PCA contains two priority encoders (U49, U75), a D-type latch (U63), and several gates (U54B, U56A-D, U57A). This main interrupt system inputs each 9100A/9105A interrupt. When one interrupt or any number of interrupts go active low, U49 and U75 prioritize the interrupt to honor first. The highest priority interrupt is the Parity Error Interrupt, and the lowest priority is the Self-Vectored Interrupt. The correct priority is assigned to the interrupt control signals (IPL0, IPL1, and IPL2). When an interrupt acknowledge cycle occurs, U63 provides the correct interrupt vector to the data bus, and the reading produces a DTACK-. During a level 1 or self-vectored interrupt, U63 and the READINT- signal are disabled by EXT-INTA. An interrupt acknowledge is sent to the interrupting device through either the Multi-Function Interface PCA (MCINTA-) or the Expansion PCA (ECINTA-). The interrupting device can then supply the DTACK- and the vector.

Table 3-4. Interrupt Vector Table

Level	Number	Name	Hex Vector	Hex Address
*	RESET	Reset	00	00000
*	BERR	Bus Error	02	00008
7	I15	Parity Error Interrupt	8F	0023C
6	I14	Floppy Data Interrupt	9F	0027C
5	I13	DTIO # 1 Interrupt	AF	002BC
4	I12	DTIO # 2 Interrupt	BF	002FC
3	I11	MFI Card Interrupt 2	CF	0033C
2	I10	Expansion Card Interrupt 2	DF	0037C
1	I9	Floppy Control Interrupt	EF	003BC
-	I8	Not Usable	--	-----
1	I7	Probe Interrupt	78	001E0
1	I6	I/O Over Current Interrupt	79	001E4
1	I5	Pod Interrupt (see below)	7A	001E8
1	I4	Pod Power Fail Int (see below)	7B	001EC
1	I3	I/O Module General Interrupt	7C	001F0
1	I2	I/O Module DCE Interrupt	7D	001F4
1	I1	Video Controller Interrupt	7E	001F8
1	I0	Self-Vectored Interrupt	--	-----
-	--	No Interrupt	77	001DC

Interrupts and interrupt acknowledge for the MFI and expansion assemblies are handled in the same manner as bus requests and bus grants. Several sections of U64 and U65 provide a latch upon receipt of an interrupt to ensure that the first interrupting device receives the interrupt acknowledge.

Parity Error Interrupt

The 9100A/9105A checks parity on RAM reads. The 9100A/9105A tests high and low bytes separately. If the RAM read is a byte access, only the byte being read is tested. When a parity error is detected, the non-maskable Parity Error Interrupt (I15) is set, and microprocessor status information is latched. The latch is readable at address 098000 and is described in Table 3-5.

3/Theory of Operation

Table 3-5. Microprocessor Status Latches U61 & U62

BIT #	15	14	13	12	11	10	9	8	7	6	5	4	3	2	1	0
NAME	FC1	PH	PL	A20	A19	A18	A17	A16	A15	A14	A13	A12	A11	A10	A9	A8

- o FC1 is Function Control 1 from the microprocessor. It is low if the error occurred during a data access, and it is high if the error occurred during a program access.
- o PH and PL are Parity High and Parity Low. One or both of these are set to indicate if the high or low byte of address had the error.
- o A20 through A8 are the top bits of the address bus, allowing for error location within 256 bytes.

The latched information allows the processor to determine which 256-byte block of memory failed, whether the error was in the high or low byte, and if the failed location contained data or a program. When the processor reads this latch, the interrupt automatically clears.

Floppy Data Interrupt

The Floppy Data Interrupt is generated by the floppy controller either when it needs the next byte of data while doing a write or when the next byte of data is available in read mode. The interrupt is automatically cleared when the byte is received or read. The interrupt can be enabled or disabled by a bit in the floppy controller latch, and it can be individually polled at DTIO #2 Input Port, bit 4.

DTIO #1 Interrupt

The DTIO #1 Interrupt is generated by the DTIO (Dual UART/Timer/IO) #1 in response to a variety of conditions that may include the following:

- o Transmit Buffer Empty
- o Receive Buffer Full
- o Break Received
- o Timer Interrupt
- o Pod Change
- o 500 millisecond (Frequency Gate)

All possible interrupts can be polled at the ISR (Interrupt Status Register) of the DTIO. A separate register, the IMR (Interrupt Mask Register), is used to program which of the possible interrupts is allowed to generate an interrupt. After an interrupt is generated, the ISR must be read to determine the cause. Different actions are needed to reset the different types of interrupts.

DTIO #2 Interrupt

The DTIO #2 Interrupt is generated by the second DTIO and is similar in function to the DTIO #1 Interrupt. Possible DTIO #2 conditions include:

- o Transmit Buffer Empty
- o Receive Buffer Full
- o Break Received
- o Timer Interrupt
- o Disk Change

MFI Card Interrupt 2

This interrupt is generated by a peripheral on a card plugged into the Multi-Function Interface (MFI) Card Slot. This interrupt is intended to be used by the SCSI controller chip under program control. This interrupt can be software disabled and polled instead. The MFI Card Interrupt is not used on the 9105A.

Expansion Card Interrupt 2

The Expansion Card Interrupt is reserved for devices connected to the expansion bus.

Floppy Controller Interrupt

The Floppy Controller Interrupt is generated by the floppy controller in response to a variety of conditions. The interrupt status register of the chip must first be read to determine the cause. This interrupt can be individually polled at DTIO #2 Input Port, bit 5.

Probe Interrupt

The Probe Interrupt is generated by the single-point probe for either a blown fuse or a button press. A probe chip status register read is performed to determine the cause.

3/Theory of Operation

I/O Overcurrent Interrupt

The I/O Module power supply generates an overcurrent interrupt, (IOOCI), when the current limit is exceeded. The interrupt is generated and latched on the Probe-I/O PCA, located in the mainframe. If this interrupt should occur, a control signal (ODRESET-) is sent to the I/O Module, which instantly turns off the overdrivers. Before clearing the interrupt, the overdrivers must be written to the tristate condition.

Pod Interrupt and Pod Power Fail Interrupt

The pod interrupts (I4, I5) are available and are polled, but they are not used by the 9100A/9105A.

I/O Module General Interrupt

This interrupt can be caused by a button press or a blown fuse on an I/O Module. The interrupt status register(s) on the I/O Module(s) must be read to determine the cause.

I/O Module Data Compare Equal Interrupt

The I/O Module Data Compare Equal Interrupt is generated by one of the I/O Modules when the programmed data compare register matches the input data. This interrupt can also be enabled to toggle MAINSTAT and/or ABORT to the pod. This allows DCE to cause the pod to exit quickly from RUNUUT or abort a test on a predetermined condition.

Video Controller Interrupt

The Video Controller Interrupt is reserved for use by the Video Controller PCA. The present pca does not use this interrupt.

Self-Vectored Interrupt

The Self-Vectored Interrupt (I0), is a special case. It can be generated by more than one device on either the MFI PCA Slot, or the Expansion Bus PCA Slot. A separate Interrupt Acknowledge (INTA) is sent to each pca slot to indicate which interrupt is being acknowledged. The initiating device must supply a vector and DTACK- or a VPA- (for auto-vectored mode) when it is acknowledged.

No Interrupt

This vector is read if no interrupts are pending or if the interrupting device removed the request before the interrupt acknowledge cycle.

Asynchronous Execution

The 68000 can operate independently of the clock frequency by using only the handshake lines (AS-, UDS-, LDS-, DTACK-, BERR-, HALT-, and VPA-) for data transfer control. The AS- signal is issued by the microprocessor to begin the bus cycle. The data strobe signals verify that the data is valid on a write cycle. The memory space or peripheral places the requested data on the bus for a read cycle or latches the data on a write cycle. The DTACK- signal is issued by the data source to end the bus cycle.

If there is no response from the data source or if a wrong address is accessed, the BERR- or BERR- and HALT- are sent to the 68000 to abort or rerun the bus cycle. On a read cycle, the DTACK- signal can be sent before data is valid. A maximum of 90 nanoseconds is then available for valid data to be latched in the 68000. No maximum length of time is required between AS- and DTACK- signals.

Reset Signal Description and Generation

The following paragraphs describe the RESET- signal types, their use, and how they are produced on the Main PCA. The four types of resets are as follows:

- o Power-Up Reset

This is a "cold" start. It occurs at power up, allowing the processor to initialize the system.

- o External Reset

The hardware has an external switch that allows the user to reset the system. This reset button is debounced and shaped so it will not harm the RAM data. (The user probably was experiencing a situation that was abnormal to be using the reset button).

- o Power Glitch Reset

The mainframe has a special chip (U87) that detects the 5V dc supply falling below 4.5V dc. The length of the reset pulse is equal to the length of the power low time plus the time controlled by C12. If the power goes bad for a long time, the RAM data has probably been lost.

- o Software Reset

A Software Reset does not actually reset the microprocessor. Instead, it is a way for the software to toggle the RESET- line. A Software Reset can be used to reinitialize some peripherals such as the Floppy Disk Controller or the Application Keypad/VF Display Controller.

3/Theory of Operation

The reset circuitry located on the Main PCA contains a triggerable multivibrator (U88A), the external reset button (SW1), a power monitor (U87), two Schmidt trigger inverters (U71D, U71E) and a D-type flip-flop (U79A). The reset circuit contains a debounce circuit that cleans up the Ext-Reset signal once the user pushes SW1. U88A produces a long power up reset logic high signal during a cold startup, required by the 68000. The Power-Up Reset and Ext-Reset are gated by U78B to become the RESIN-input of U87. The U87 is used as a reset controller that supervises the supply voltage during power on. U87 keeps its output pin 5 active until the supply voltage reaches 5 volts. If the supply voltage drops below 4.7 volts, the circuit generates reset signals until 5 volts returns, to ensure a proper reset.

Address Decoding and DTACK

Address decoding for all circuits except RAM and ROM is accomplished by U17 and U70. U17 divides the low part of the address base into 64K segments. These segments are used by the floppy controller, the expansion bus connector, the multi-function interface, the probe, and the I/O Module. In addition, two segments are used by the video circuit. A final segment is further divided into 16K segments by U70. These segments are used by the UART (DTIO), interrupt logic, read parity control, and the pod.

Most address decode outputs connect to chip select inputs for the respective circuits. The DTACK- output, which instructs the microprocessor to complete the access cycle, is generated by U55 when the addressed circuit responds with the appropriate signal. For circuits requiring 0 wait states, the appropriate low signals are fed directly to U55. Other circuits require wait states to accommodate a longer access period. Parity reads, UART, and pod circuitry require one wait state. Video, floppy disk, and other pod circuits require three wait states. Signals for either number of wait states are fed through U34 and clocked into U55 by U50. U33 serves as an active pull-up for the DTACK signal out of U76.

Some peripherals require extra setup time during reads and writes. This requirement is satisfied with the new data strobe (NDS) signal from U79. During the write cycle, NDS is active one-half clock cycle after the address strobe. NDS is also withdrawn one-half clock cycle before the end of the write cycle to allow for data hold time.

RAM

RAM CONFIGURATION

Standard configuration includes 2M bytes of RAM for the 9100A and the 9105A. Either instrument can be expanded to 4M bytes of RAM. RAM is housed in single-in-line modules (SIMs), designated as U13, U14, U15, and U16. To achieve 2M bytes, four 512K-byte SIM modules are used. Memory expansion to 4M bytes can be achieved using four 1M-byte SIMs. The SIMs must be exchanged in pairs. The 9105A with serial numbers prior to 4352000 used a standard 1.5M-byte RAM configuration (two 512K and two 256K SIMs), expandable to 4M bytes as stated above.

An 8-segment DIP switch (U83) must be set for each RAM configuration. The settings are shown in Table 3-6. The RAM configuration is also saved as a code in non-volatile memory on the Main PCA (EEPROM U11).

Table 3-6. RAM Configuration (U83)

MODULE TYPE		TOTAL	ADDRESS	SWITCH
U13/U14	U15/U16	BYTES	RANGE	SEGMENTS
				1234 5678
512K	256K	1.5M	C00000-D7FFFF	1001 1011 (9B)
512K	512K	2M	C00000-DFFFFFF	1001 1001 (99)
1M		2M	C00000-DFFFFFF	0010 0001 (21)
1M	1M	4M	C00000-FFFFFFF	0011 0001 (31)

1 = ON (closed)
0 = OFF (open)

For each of these configurations, the first 8K bytes of RAM (C00000 through C01FFF) are accessible only by Supervisor Mode. An access to this area attempted by User Mode produces a Bus Error Exception and does not affect RAM contents.

RAM TIMING

To select a RAM address, U29, U30, and U31 multiplex 20 address lines (A01 through A20) into 10 address signals (RA0 through RA9). This multiplexed address is latched into RAM under control of both a row-address-strobe signal (RAS-) and a column-address-strobe signal (CAS-).

Upper (D15 through D08) and/or lower (D07 through D00) byte(s) can be read from bank 1 or 2. Bank 1 comprises U13 and U14. Bank 2 comprises U15 and U16. Clock signals and microprocessor read asynchronous bus control signals (LDS, UDS) determine read timing.

RAM REFRESH

RAM Refresh utilizes a state machine operating at approximately 33 kHz. RAM Refresh is initiated by a count of E clocks. E clocks are divided by two (U77B) and counted by U81. At every twelve E clocks, U81 generates refresh request (RFRQ). If there is no RAM access occurring at the same time, U85B generates refresh grant (RFGT). If a RAM access is occurring, RFGT is not generated until the end of the RAM access cycle. One-half cycle after RFGT, refresh address enable (RFAE) is generated to turn off the normal multiplexed address lines and enable the refresh address outputs from U26. One-half cycle later, U80A generates refresh RAS (RRAS), which performs the actual refresh. Refresh address is then disabled, and, through U68B, U81 is cleared. RFRQ and RFGT are thereby cleared. On each refresh, U85A changes states, clocking the refresh address output from U26. The Refresh cycle repeats 256 times in approximately 4 ms.

3/Theory of Operation

U85, pin 6 changes state for each refresh cycle. This transition is used as the lowest bit of the RAM refresh address through U33. On every change of the low bit, the clock to U26 is enabled to obtain the other eight bits of RAM refresh address (a nine-bit address).

Note that other uses of the U85 33 kHz signal include power supply switching and do not impact the scope of this discussion.

RAM PARITY

On every write cycle, parity is generated for each data byte. The high byte is generated by U24, and the low byte is generated by U23. The ninth bit into the parity comparator is held low during a write. If the parity on the rest of the bits is even, the EV (even) output of the parity comparator goes high. This output serves as a ninth bit of data, resulting in odd parity for the nine bits. If the parity on the rest of the bits is already odd, the ninth bit (EV) remains low to keep the parity odd.

On read cycles, this ninth bit serves as read data. Even parity at this time results in a parity error, which is latched for both high and low bytes by U73. U73 also outputs PLATCH (parity latch) to U61 and U62, latching the address and parity status bits. Parity interrupt is also generated at this time by U78. Refer to the Parity Interrupt description. The latches are cleared by either a reset or a read of the parity latches.

ROM

Sockets for U45/U48 (High Bank) and U46/U47 (Low Bank) accept 256K byte or 512K byte EPROMs, or 1M byte mask ROMs. A PAL (Programmable Array Logic), U28, provides four wire jumpers. Each jumper combination specifies select logic for the desired ROM configuration as shown in Table 3-7.

Table 3-7. ROM Select Logic

JUMPERS				SIZE	ADDRESSES	
W4	W3	W2	W1		Low Bank	High Bank
X	X	0	0	256K	00000 - 0FFFF	na
X	X	0	1	256K	00000 - 0FFFF	na
X	X	1	0	512K	00000 - 1FFFF	na
X	X	1	1	1M	00000 - 3FFFF	na
0	0	X	X	empty	na	none present
0	1	X	X	256K	na	40000 - 4FFFF
1	0	X	X	512K	na	40000 - 5FFFF
1	1	X	X	1M	na	40000 - 7FFFF

(0 = closed, 1 = open)

POD Interface

The Pod Interface accommodates information transfer in two bytes. A low byte is used as an 8-bit, bidirectional data port. U42 handles data (D00 through 07) inputs to the 9100A/9105A. Transparent latch U37 handles data outputs to the pod. An 8-bit, bidirectional high byte (status register) transfers information on data lines D08 through D15, using U58 for inputs and U53 for latched outputs.

Bit assignments for both status and data bytes are shown in Table 3-8. Latched outputs are cleared low by a reset.

Data or response from the Pod is read at handshake completion. Data from the 9100A/9105A to the Pod is latched when written. `POD_OE` must be active to enable the output buffer.

Refer to Table 3-9 for the pinout and function of each signal line for the Pod Interface.

On the 9100A, presence of a pod is indicated on the `PODPRESENT-` line when a valid signal is detected on the `POWERFAIL` line (J9-11).

Table 3-8. Pod Control Port Bit Assignment

STATUS BYTE (ADDRESS 9C000)		
BIT	INPUT (U58)	LATCHED OUTPUT (U53)
D15	MAINSTAT	MAINSTAT
D14	POD_OE	POD_OE
D13	PODSTAT-	POD_RESET
D12	ABORT	ABORT
D11	PODPRESENT-	ENDCE-ABORT
D10	DCE	ENDCE-MAINSTAT
D09	PODINT	EN-PODINT
D08	POWERFAIL	EN-PWRINT

NAME	I/O	DESCRIPTION
MAINSTAT	I/O	Handshake line from 9100A/9105A to the Pod.
POD_OE	I/O	Enables the Pod data buffer for write data. A high true signal enables (drives) the latched output data onto the Pod data lines (POD0 through POD7).
POD_RESET	0	Signal from 9100A/9105A to reset the Pod.
ABORT	0	Signal from the 9100A/9105A telling the Pod to abort a long operation.

Table 3-8. Pod Control Port Bit Assignment (cont)

ENDCE-ABORT	0	Enables the I/O Module Data Compare Equal (DCE) Signal to set the ABORT signal to the Pod. This allows the Pod to abort an operation upon a preprogrammed condition.
ENDCE-MAINSTAT	0	Enables the I/O Module Data Compare Equal (DCE) signal to set the MAINSTAT signal to the Pod. This allows the Pod to abort a RUN UUT upon a preprogrammed condition or address.
EN-PODINT	0	Enables the PODINT Signal from the Pod to interrupt the processor.
EN-PWRINT	0	Enables the POWERFAIL Signal from the Pod to interrupt the processor.
PODSTAT-	I	Active low handshake line from Pod.
PODPRESENT-	I	A low true signal that indicates when a Pod is connected to the Pod Interface connector. This signal is derived from the Pod interface POWERFAIL signal. This signal can be enabled to generate an interrupt through the DTIO on change of state, (i.e., connecting or disconnecting the Pod).
DCE	I	Monitors the I/O Module Data Compare Equal (DCE) Signal.
PODINT	I	Buffered active high interrupt line from certain pods. This line will also generate an interrupt if enabled by EN-PODINT.
POWERFAIL	I	Active when Pod detects a bad UUT power supply. Can be enabled to cause an interrupt if EN-PWRINT is set.
DATA BYTE (ADDRESS 9C001)		
BIT	INPUT (U42)	LATCHED OUTPUT (U37)
D07-D00	READ DATA	WRITE DATA

Table 3-9. Pod Interface Pinout

NAME	FUNCTION	PIN
POD0	Data bit 0	8
POD1	Data bit 1	20
POD2	Data bit 2	7
POD3	Data bit 3	19
POD4	Data bit 4	6
POD5	Data bit 5	18
POD6	Data bit 6	5
POD7	Data bit 7	17
MAINSTAT-	Handshake	12
PODSTAT-	Handshake	24
PODRESET-	Resets Pod	23
POWERFAIL	Power out of tolerance	11
PODINT-	Pod interrupt	1
ABORT-	abort	9
PODSYNC-	Pod Sync	10
SYNC SH	Pod sync shield	22
+5V	+5 volt power	2, 15
+12V	+12 volt power	14
-5V	-5 volt power	21
GND	Ground	4, 13, 16, 25
X SHLD	Pod cable shield	3

3/Theory of Operation

DUART-Timer-I/O

The 9100A/9105A uses two 2681 DTIOs (U12 as DTIO1 and U7 as DTIO2). Each performs multiple Dual Asynchronous Receiver/Transmitters (DUART), timers, and input/output functions with two serial ports, one parallel input port, one parallel output port, and a timer.

For DTIO1, register addressing and descriptions are given in Table 3-10. Specific functions are:

- o Programmable Timer Interrupt
 - OP3: timer output (50 ms)
 - INT-: Interrupt Request to microprocessor
- o EEPROM Control
 - IP4: data output from EEPROM
 - OP4: data input to EEPROM
 - OP5: serial clock to EEPROM
 - OP6: chip enable to EEPROM
- o Pod Present Detection
 - IP2: PODPRESENT change-of-state detection (can generate interrupt)
- o Frequency Gate Generation/Detection
 - IP3: FGATE frequency gate input
 - OP2: frequency gate load
- o DTIO1, Serial Port A: Application Keypad/Display
 - TxDA: Data to Application Keypad/Display
 - RxDA: Data from Application Keypad/Display
 - CTSA- (IP0): Clear to Send from Application Keypad/Display.

Transmit and receive are at 19.2K baud. This port automatically holds off transmission data when the Keypad/Display is too busy to accept data.

- o DTIO1, Serial Port B: Earth Referenced RS-232 Port #2
 - TxDB: Transmit Data
 - RxDB: Receive Data
 - CTSB- (IP1): Clear to Send
 - RTSB- (OP1): Request to Send

Supports programmable baud rates, data width, stop bits, parity, and interrupts on buffer conditions, with three-deep FIFO on both transmit and receive.

For DTIO2, register addressing and descriptions are provided in Table 3-11. Specific functions are:

- o DTIO2, Serial Port A: Programmers Keyboard
RxDA: Programmers Keyboard Data

The baud rate is 1200 baud. The keyboard has a separate reset line, which is connected to OP7 of DTIO #2.

- o DTIO2, Serial Port B: System Referenced RS-232 Port #1
TxDB: Transmit Data
RxDB: Receive Data
CTSB- (IP1): Clear to Send
RTSB- (OP1): Request to Send

Supports programmable baud rates, data width, stop bits, parity, and interrupts on buffer conditions, with three-deep FIFO on both transmit and receive.

- o Second Programmable Timer Interrupt
OP3: Timer output, Divide by 16
INT-: Interrupt Request to microprocessor
- o Floppy Disk Change Detection
IP2: Drive 1 Disk Change (can generate interrupt)
IP3: Drive 2 Disk Change (can generate interrupt)
- o Floppy Disk Interrupt Monitor
IP4: Read Floppy Drive Data Interrupt Bit
IP5: Read Floppy Drive Interrupt Bit
- o Programmers Keyboard Reset
OP7: KBRST- Keyboard Reset
- o I/O Module Power Supply Control
OP5: I/O Module Reset
OP6: I/O Module Low Current
IP6: Input from I/O or Probe Board (spare)
- o Other
OP2: RUN UUT LED Drive
OP4: Disk Access LED Drive

Table 3-10. DTIO #1 (Channels A, B)
Register Addressing and Description

MSA	\$90001	* mode register channel A (R/W)
SRA	\$90003	* status register channel A (R)
CSRA	\$90003	* clock select register A (W)
CRA	\$90005	* command register A (W)
ADATA	\$90007	* data holding registers A (R/W)
IPCR	\$90009	* input port change register (R)
ACR	\$90009	* aux control register (W)
ISR	\$9000B	* interrupt status register (R)
IMR	\$9000B	* interrupt mask register (W)
CTU	\$9000D	* counter/timer upper data (R)
CTL	\$9000F	* counter/timer lower data (R)
CTUR	\$9000D	* counter/timer upper register (W)
CTLR	\$9000F	* counter/timer lower register (W)
MRB	\$90011	* mode register channel B (R/W)
SRB	\$90013	* status register channel B (R)
CSRB	\$90013	* clock select register B (W)
CRB	\$90015	* command register B (W)
BDATA	\$90017	* data holding registers B (R/W)
INP	\$9001B	* input port (R)
OPCR	\$9001B	* output port configuration register (W)
SCC	\$9001D	* start counter command (R)
SOPB	\$9001D	* set output port bits command (W)
STC	\$9001F	* stop counter command (R)
ROPB	\$9001F	* reset output port bits command (W)

**Table 3-11. DTIO #2 (Channels C, D)
Register Addressing and Description**

MRC	\$90000	* mode register channel C (R/W)
SRC	\$90002	* status register channel C (R)
CSRC	\$90002	* clock select register C (W)
CRC	\$90004	* command register C (W)
CDATA	\$90006	* data holding registers C (R/W)
IPCR	\$90008	* input port change register (R)
ACR	\$90008	* aux control register (W)
ISR	\$9000A	* interrupt status register (R)
IMR	\$9000A	* interrupt mask register (W)
CTU	\$9000C	* counter/timer upper data (R)
CTL	\$9000E	* counter/timer lower data (R)
CTUR	\$9000C	* counter/timer upper register (W)
CTLR	\$9000E	* counter/timer lower register (W)
MRD	\$90010	* mode register channel D (R/W)
SRD	\$90012	* status register channel D (R)
CSRD	\$90012	* clock select register D (W)
CRD	\$90014	* command register D (W)
DDATA	\$90016	* data holding registers D (R/W)
INP	\$9001A	* input port (R)
OPCR	\$9001A	* output port configuration register (W)
SCC	\$9001C	* start counter command (R)
SOPB	\$9001C	* set output port bits command (W)
STC	\$9001E	* stop counter command (R)
ROPB	\$9001E	* reset output port bits command (W)

MICROFLOPPY DISK SYSTEM

Disk Drive

The 9100A uses one OEM 3.5-inch, double-sided, double-density microfloppy disk drive. On the 9105A, two of these drives are used. Each disk uses 80 tracks per side (0 to 4F hex), formatted as 16 sectors of 256 bytes per track, for a formatted capacity of 640K bytes. Each drive is accessed and formatted through the Floppy Controller.

Floppy Drive Controller

An FD1797 floppy controller (U43) and an FDC9229 Floppy Disk Interface Circuit (FDIC) are used for floppy drive control. The floppy controller does not format the floppy disk; this function is performed through software. The controller does perform the following functions:

- o It searches for the correct track and sector.
- o It calculates CRC values and inserts all required CRC's during a write.
- o It serializes data on a write and decodes data on a read.

3/Theory of Operation

The FDIC circuit (U44) performs digital data separation and track-selectable write pre-compensation.

Addresses for U43 Floppy Controller registers are shown in Table 3-12.

Table 3-12. Floppy Controller Addressing

NAME	ADDRESS	DESCRIPTION
DCOMND	\$80001	* Disk Command Register (write)
DSTAT	\$80001	* Disk Status Register (read)
DTRACK	\$80003	* Disk Track Register (read/write)
DSECTOR	\$80005	* Disk Sector Register (read/write)
DDATA	\$80007	* Disk Data Register (read/write)

Output latch U60 (address 80000) controls drive selects and other features. Table 3-13 describes U60 outputs.

Table 3-13. Floppy Drive Control Latch Outputs

NAME	DESCRIPTION															
DS0, DS1	Drive Selects (turn on motor and enable communications with floppy controller for one drive at a time.)															
SPARE	(not used)															
MINI	Controls Floppy Controller clock to select data rate for mini (5 1/4- or 3 1/2-inch, logic low) or standard (8-inch, logic high) drive.															
DENS	Selects between single density (logic low) and standard double density (logic high).															
P0, P1	Selects the write pre-compensation time, as shown below.															
	<table><thead><tr><th>P1</th><th>P0</th><th>TIME</th></tr></thead><tbody><tr><td>0</td><td>0</td><td>0 ns</td></tr><tr><td>0</td><td>1</td><td>125 ns</td></tr><tr><td>1</td><td>0</td><td>250 ns</td></tr><tr><td>1</td><td>1</td><td>375 ns</td></tr></tbody></table>	P1	P0	TIME	0	0	0 ns	0	1	125 ns	1	0	250 ns	1	1	375 ns
P1	P0	TIME														
0	0	0 ns														
0	1	125 ns														
1	0	250 ns														
1	1	375 ns														
EN-INT:	Enables the floppy data interrupt.															

Interrupts

The Floppy Data Interrupt is generated by the floppy controller when it needs the next byte of data while doing a write or when the next byte of data is available in read mode. The Floppy Data Interrupt is automatically cleared when the byte is received or read.

The Floppy Controller Interrupt is generated by the floppy controller in response to a variety of conditions. The chip's interrupt status register must first be read to determine the cause. This interrupt can be polled at DTIO #2 Input Port, bit 5.

HARD DISK SYSTEM

On the 9100A, a standard-feature, O.E.M.-supplied hard disk occupies the space otherwise used in the 9105A for a second floppy disk drive. System software that is resident on this 20M byte, 3.5-inch hard disk is backed up with floppy disks.

The hard disk controller, also an O.E.M. product, attaches to the Internal SCSI Connector (J2) on the Multi-Function Interface (MFI) PCA, which is plugged into J6 on the Main PCA.

POWER SUPPLY

An OEM switching power supply is used to operate from a line voltage of 90 to 132V ac (47-440 Hz) or 180 to 264V ac (47-63 Hz). Single outputs of +5.1V dc and -5V dc and two outputs of +12V dc are provided. The 9100A power supply is rated at 150W (maximum). Pin designations for the power supply are presented in Table 3-14.

Table 3-14. Power Supply Pinout

DC OUT				AC IN	
TB1-1	+12V	4.0 Amps +/-	5%	TB2-1	AC Hot
-2	+12V	2.0 Amps +/-	10%	-2	AC Neutral
-3	-5V	1.0 Amp +/-	5%		
-4,5,6	Power supply common			-3	AC Earth ground
-7,8	+5.1V	15.0 Amps +/-	4%		

OPERATOR'S DISPLAY

Vacuum-Fluorescent Display (VFD)

The vacuum-fluorescent display uses a 254 by 26 pixel layout. Each character comprises a six wide by eight deep group of pixels, allowing for a total width of 42 characters per line (numbered 0 through 41). A pseudo-character at position 42 allows for a backspace to effect character 41. The cursor cannot be positioned prior to character 0 or after character 42. The display contains up to four lines (numbered 0 through 3).

3/Theory of Operation

A total depth of 26 pixels allows for display of either three lines separated with a blank row (character mode), or three full lines and a partial fourth line (graphics mode). The character mode is the default at startup.

The vacuum fluorescent display is in essence a tube, with the filaments forming a heated cathode. A switcher circuit supplies 12V to one side of the filament and about 4V to the other side. These voltages are switched at the end of each scan cycle (after all grids have been scanned). The switching is synchronized to the scan rate to prevent flicker.

Each switching cycle is controlled by U14 and its associated output drivers. Two discrete actions occur at the start of each cycle. The filament drive is first switched off briefly. Next, the filament is driven (through Q2/Q6 or Q3/Q5) in the direction opposite to that used in the last cycle. Transistors Q2 and Q6 are used during one cycle direction, and Q3 and Q5 are used during the other cycle direction. U31 supports the filament drive switch off function.

The vacuum fluorescent tube grids are driven in pairs. Grid input (GI) is held high for two clock periods at the beginning of the refresh cycle. The grid drivers are shift registers that are clocked to the next set of grids with each refresh scan. The grids are driven in pairs, G1 and G2, followed by G2 and G3, and so on. This scheme is illustrated in Figure 3-4.

Anodes comprise rows A1 through D24, which are also driven in pairs. Rows A and B (or C and D) are enabled together. If dots associated with only one row are on, both rows in the pair are still enabled.

The Z8 display processor, U1, both receives inputs, data, and commands from the main microprocessor and sends data out through a TTL-level RS-232 interface. Divider U4 uses the Y1 reference clock signal (fed through U1) to derive timing signals for the circuit. U1 uses multiplexed address timing for data output; U2 latches the address for use with RAM and shift registers.

U1 receives the code for the character to be displayed, converts the code to the appropriate pixel pattern, and then writes the converted code to the appropriate row and column of the display RAM. However, U1's main function is to refresh the display tube. U1 uses pointers to the grid counters, reads data from display RAM, and, by holding A11 high, simultaneously writes data to serial shift registers U23 and U24. The state machines U14B and U15B shift the data out of the U23/U24 parallel-serial converters into the correct row drivers. This process is repeated four times for each refresh, at which time the data is latched into the row drivers.

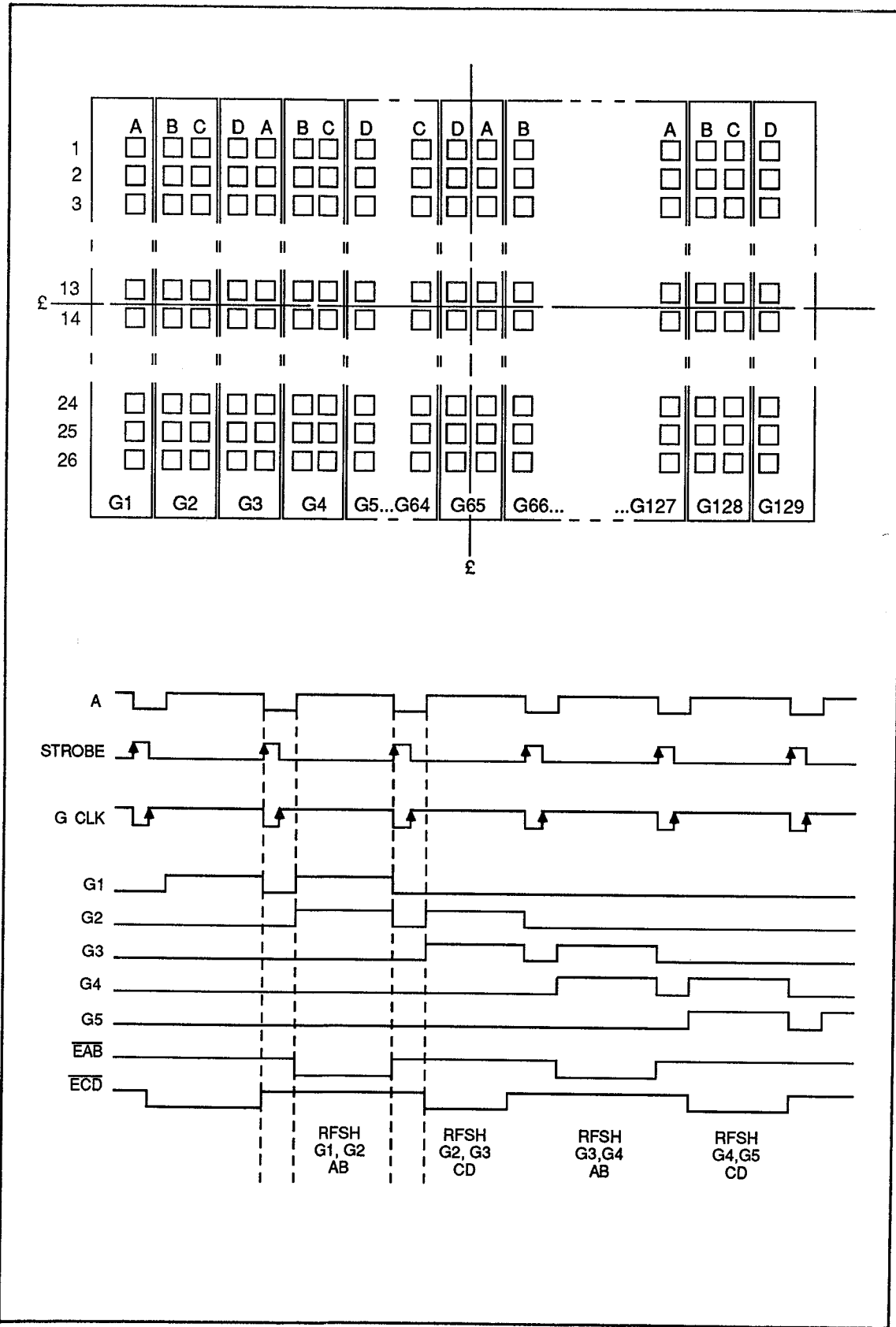

Figure 3-4. Vacuum Fluorescent Display

3/Theory of Operation

The SET- pulse from U1 provides the master timing signal for this refresh process. When SET- is true, grid input (GI) is also true. U13 and U14 provide the 1/4-3/4 duty cycle signal A, which is the master timing signal. One A cycle corresponds to one grid pair refresh. STROBE is used to strobe data into the row drivers. GCLK (the inverse of STROBE) is used to clock the grid drivers to the next position (G1/G2 to G2/G3, etc.). Row driver enable is provided by EAB- (for rows A and B) and by EAD- (for rows C and D). Outputs to display grid and row drivers incorporate pull-up resistors to provide valid MOS voltage levels. All grid and row drivers are disabled at reset or power-up by DSPYE (display enable) from U25.

Both grid and row currents flow through the filaments. Therefore, after a reset, the processor, U1, clears all grids and rows before a new enable is output. This action prevents filament destruction due to excess current.

Auxiliary circuitry includes the LED drivers. The RUN UUT and DISK ACCESS LEDs are driven by the Main PCA; all other LEDs are controlled by U1 (with latch U30) on the Display Interface PCA.

At the end of each display refresh, the processor scans the keypad by writing to U26, a 4-to-1 decoder. U26 drives one of the column lines low. The processor then reads the ROWBUSS to determine if any row line has been pulled low, signifying a keypress. Only one key press at a time is recognized by the processor. That key press must be withdrawn before another can be recognized. Multiple key presses are not recognized.

U28 is a shift counter whose output is used for character or graphics mode. In the character mode, nine bits are shifted out (the ninth bit designates a blank between text lines). This cycle is repeated three times, and five bits are shifted out on the fourth cycle to yield the 32 bits. In the graphics mode, an eight-bit load/shift-out cycle is repeated four times to derive 32 bits.

U29 provides a free-running oscillator for the beeper. The processor can enable either or both of two tones.

Resets are handled by U18 and U31, which reset the processor, clear all latched LEDs through U30, and clear all outputs of U25.

A 20-wire ribbon cable connects the Operator Display and Keypad to a Main PCA serial port. Data is exchanged at 19.2K baud. Ribbon cable connections are described in Table 3-15.

Displayable Characters

The characters shown in Table 3-16 (hex values 20 through FF) are displayable. Some of the display characters are not available through TL/1 programs, but can be accessed by the Main PCA processor using the hex values listed. The character codes shown in Table 3-17 are control codes of the display. These codes, which do not represent displayable characters, perform certain control functions.

Table 3-15. Ribbon Cable Connections

LINE	USE	TYPE	DESCRIPTION
10, 12, 14, 20	Ground		
16, 18	12 Volts	Power	Power for filament and for bell
6, 8	5 Volts	Power	Power for logic
4	70 Volts	Power	Power for vacuum fluorescent display
1, 5	Earth		Green Ground
19	Key		Key for alignment
17	RESET	Input	Active high resets the processor
15	TRANSMIT	Output	Transmits data to Main PCA at 19.2K baud
13	RECEIVE	Input	Receives data from Main PCA at 19.2K baud
11	CTS-	Output	Active low holds off Main PCA transmit
9	ROW7	Input	Last row of the keypad scan
7	COLUMN9	Output	Last column of the keypad scan
3	RUN-LED	Input	Controls "RUN UUT" LED
2	DISK-LED	Input	Controls "DISK ACCESS" LED

Table 3-16. Display Characters

20 = ' '	30 = '0'	40 = '@'	50 = 'P'	60 = ' '`	70 = 'p'
21 = '!'	31 = '1'	41 = 'A'	51 = 'Q'	61 = 'a'	71 = 'q'
22 = '"'	32 = '2'	42 = 'B'	52 = 'R'	62 = 'b'	72 = 'r'
23 = '#'	33 = '3'	43 = 'C'	53 = 'S'	63 = 'c'	73 = 's'
24 = '\$'	34 = '4'	44 = 'D'	54 = 'T'	64 = 'd'	74 = 't'
25 = '%'	35 = '5'	45 = 'E'	55 = 'U'	65 = 'e'	75 = 'u'
26 = '&'	36 = '6'	46 = 'F'	56 = 'V'	66 = 'f'	76 = 'v'
27 = '''	37 = '7'	47 = 'G'	57 = 'W'	67 = 'g'	77 = 'w'
28 = '('	38 = '8'	48 = 'H'	58 = 'X'	68 = 'h'	78 = 'x'
29 = ')'	39 = '9'	49 = 'I'	59 = 'Y'	69 = 'i'	79 = 'y'
2A = '*'	3A = ':'	4A = 'J'	5A = 'Z'	6A = 'j'	7A = 'z'
2B = '+'	3B = ';'	4B = 'K'	5B = '['	6B = 'k'	7B = '{'
2C = ','	3C = '<'	4C = 'L'	5C = '\'	6C = 'l'	7C = ' '
2D = '-'	3D = '='	4D = 'M'	5D = ']'	6D = 'm'	7D = '}'
2E = '.'	3E = '>'	4E = 'N'	5E = '^'	6E = 'n'	7E = '~'
2F = '/'	3F = '?'	4F = 'O'	5F = '_'	6F = 'o'	7F = Full Block
80 = reduced '0' (upper left)		88 = reduced '8' (upper left)			
81 = reduced '1' (upper left)		89 = reduced '9' (upper left)			
82 = reduced '2' (upper left)		8A = bracket (lower right)			
83 = reduced '3' (upper left)		8B = bi-directional pin			
84 = reduced '4' (upper left)		8C = large pin above chip			
85 = reduced '5' (upper left)		8D = I.C. pin above chip			
86 = reduced '6' (upper left)		8E = up arrow			
87 = reduced '7' (upper left)		8F = down arrow			
90 = reduced '0' (lower right)		98 = reduced '8' (lower right)			
91 = reduced '1' (lower right)		99 = reduced '9' (lower right)			
92 = reduced '2' (lower right)		9A = bracket (upper left)			
93 = reduced '3' (lower right)		9B = omega			
94 = reduced '4' (lower right)		9C = large pin below chip			
95 = reduced '5' (lower right)		9D = I.C. pin below chip			
96 = reduced '6' (lower right)		9E = left arrow			
97 = reduced '7' (lower right)		9F = right arrow			

Table 3-16. Display Characters (cont)

A0 = reduced '0' (center)	A8 = reduced '8' (center)
A1 = reduced '1' (center)	A9 = reduced '9' (center)
A2 = reduced '2' (center)	AA = divide sign
A3 = reduced '3' (center)	AB = +/-
A4 = reduced '4' (center)	AC = micro
A5 = reduced '5' (center)	AD = inverted '-'
A6 = reduced '6' (center)	AE = pi
A7 = reduced '7' (center)	AF = pound sign
B0 = reduced inverted '0' (center)	B8 = reduced inverted '8' (center)
B1 = reduced inverted '1' (center)	B9 = reduced inverted '9' (center)
B2 = reduced inverted '2' (center)	BA = I.C. head
B3 = reduced inverted '3' (center)	BB = I.C. body segment (full splat)
B4 = reduced inverted '4' (center)	BC = reduced splat (center)
B5 = reduced inverted '5' (center)	BD = box
B6 = reduced inverted '6' (center)	BE = double box
B7 = reduced inverted '7' (center)	BF = super-reduced splat
C0 = boxed super-reduced splat	C8 = reduced inverted 'H'
C1 = reduced inverted 'A'	C9 = reduced inverted 'I'
C2 = reduced inverted 'B'	CA = reduced inverted 'J'
C3 = reduced inverted 'C'	CB = reduced inverted 'K'
C4 = reduced inverted 'D'	CC = reduced inverted 'L'
C5 = reduced inverted 'E'	CD = reduced inverted 'M'
C6 = reduced inverted 'F'	CE = reduced inverted 'N'
C7 = reduced inverted 'G'	CF = reduced inverted 'O'
D0 = reduced inverted 'P'	D8 = reduced inverted 'X'
D1 = reduced inverted 'Q'	D9 = reduced inverted 'Y'
D2 = reduced inverted 'R'	DA = reduced inverted 'Z'
D3 = reduced inverted 'S'	DB = logic 1 level
D4 = reduced inverted 'T'	DC = logic x level
D5 = reduced inverted 'U'	DD = logic 0 level
D6 = reduced inverted 'V'	DE = 0 -> 1 edge
D7 = reduced inverted 'W'	DF = 0 -> x edge
E0 = x -> 1 edge	E8 = reduced inverted *
E1 = 1 -> 0 edge	E9 = reduced inverted up arrow
E2 = 1 -> x edge	EA = reduced inverted down arrow
E3 = x -> 0 edge	EB = not yet defined
E4 = left inverse line	EC = not yet defined
E5 = left line	ED = not yet defined
E6 = right inverse line	EE = not yet defined
E7 = right line	EF = not yet defined
F0 through FF = not yet defined	

Two control modes are available. The first, display mode, specifies display of the two bit maps (page 1 or page 2) as follows:

- o Display Mode 0 Alternately displays Page 1 and Page 2 at a fixed rate of approximately 1 Hz. Display mode 0 is the default at startup.
- o Display Mode 1 Displays Page 1 only
- o Display Mode 2 Displays Page 2 only

The second, write mode, controls placement of the character as follows:

- o Write Mode 0 Places the character in both Page 1 and Page 2. Write mode 0 is the default.
- o Write Mode 1 Places the character in Page 1 only.
- o Write Mode 2 Places the character in Page 2 only.

Table 3-17. Control Characters

HEX	FUNCTION	DESCRIPTION
00	Load bell	Load bell value
01	Time out	Set time out value
02	no op	(not used)
03	Blink	Blank location in page 2, advance cursor, and set write mode 0.
04	Flash	Put the complement of the character at the page 1 cursor into page 2, advance cursor, and set write mode 0.
05	Character mode	Place extra blank dot between lines
06	Graphics mode	No extra blank dot between lines
07	Bell	Ring bell
08	Cursor left	Move cursor one character left
09	Cursor right	Move cursor one character right
0A	Cursor down	Move cursor one line down
0B	Cursor up	Move cursor one line up
0C	Clear	Place in display mode 0, place in write mode 0, clear entire display, and home cursor
0D	<cr>	Carriage return
0E	Test	Perform tests on hardware
0F	Move cursor	Move cursor to a new location
10	<bs>	Backspace and delete
11	Annunciators	Turn annunciators on or off
12	Blink mask	Make annunciators solid or blink
13	XOR next char	XOR with display the next character and advance cursor
14	Clear to eol	Clear to end of line
15	Clear line	Clear entire line and place cursor at zero character
16	Invert next char	Invert the video of the character and advance cursor

Table 3-17. Control Characters (cont.)

17	Underline	Underline character at the cursor and advance cursor
18	Display mode 0	Set display mode 0
19	Display mode 1	Set display mode 1
1A	Display mode 2	Set display mode 2
1B	Graphics	Next 6 bytes define the graphics to be placed in the display
1C	XOR graphics	Next 6 bytes define the graphics to be XORed with the old display value
1D	Write mode 0	Set write mode 0
1E	Write mode 1	Set write mode 1
1F	Write mode 2	Set write mode 2

Annunciators

Seven LED annunciators are used with the display: BUSY, STOPPED, RUN UUT, STORING SEQ, DISK ACCESS, MORE SOFTKEYS, MORE INFORMATION. The RUN UUT and DISK ACCESS LEDs are controlled by the Main PCA; the other LEDs are controlled by the Display PCA.

OPERATOR'S KEYPAD

The 55-key keypad consists of 50 hard-labeled keys and five soft-labeled keys. An LED annunciator, located on the keypad, lights when the alpha mode is activated. Functionally, the keypad is a 9-column by 8-row matrix. Pressing a key completes a connection between a particular column output and row input.

The keypad is scanned by the Display PCA after every display refresh. If a new key closure is detected at this time, the appropriate byte is sent via the serial output to the Main PCA. Values returned for each key are shown in Table 3-18.

A tenth column output (COLUMN9) is not used on the keypad. COLUMN9 is routed (along with the ROW7 input signal) across the Main PCA to the Probe I/O PCA. This arrangement allows for scanning the external footswitch input. A closure of the footswitch connection is detected and the appropriate byte sent to the Main PCA in the same fashion as with a key closure on the keypad.

PROBE I/O MODULE INTERFACE

Overview

The Probe I/O Interface provides the interface from the mainframe to the single-point Probe, Clock Module, and the I/O Connector PCA. The Interface PCA is mounted flush to the Main PCA inside the mainframe. The Probe I/O Interface block diagram, Figure 3-5, contains the following functional block groups:

- o Address Decoding
- o Probe Interface
- o Clock Module Interface
- o Custom Delay Probe Chip
- o Custom Probe Logic Chip
- o Stop Counter
- o I/O Module Interface
- o Miscellaneous Functional Blocks

Table 3-18. Key Values

KEY	VALUE	ASCII	KEY	VALUE	ASCII
SOFTKEYS	58	X	B (1011)	42	B
F1	59	Y	SETUP MENU (P)	24	\$
F2	5A	Z	SEQ (Q)	25	%
F3	5B	[POD (R)	2C	,
F4	5C	\	ROM (S)	2D	-
F5	5D]	STIM (T)	34	4
RESET	5E	^	4 (0100)	35	5
ALPHA	20	space	5 (0101)	3C	<
EXEC (G)	21	!	6 (0110)	3D	=
PROBE (H)	28	(7 (0111)	44	D
BUS (I)	29)	(up arrow)	4C	L
READ (J)	30	0	REPEAT (-)	54	T
C (1100)	31	1	STOP	55	U
D (1101)	38	8	OPTION (U)	26	&
E (1110)	39	9	(V)	27	'
F (1111)	40	@	SYNC (W)	2E	.
ENTER YES	41	A	(X)	2F	/
CLEAR NO	48	H	RUN UUT (Y)	36	6
EDIT (.)	50	P	0 (0000)	37	7
HELP	51	Q	1 (0001)	3E	>
MAIN MENU (K)	22	"	2 (0010)	3F	?
GFI (L)	23	#	3 (0011)	46	F
IO MOD (M)	2A	*	←	47	G
RAM (N)	2B	+	(down arrow)	4E	N
WRITE (O)	32	2	→	4F	O
8 (1000)	33	3	LOOP (Z)	56	V
9 (1001)	3A	:	CONT (SPACE)	57	W
A (1010)	3B	;	footswitch	6F	o

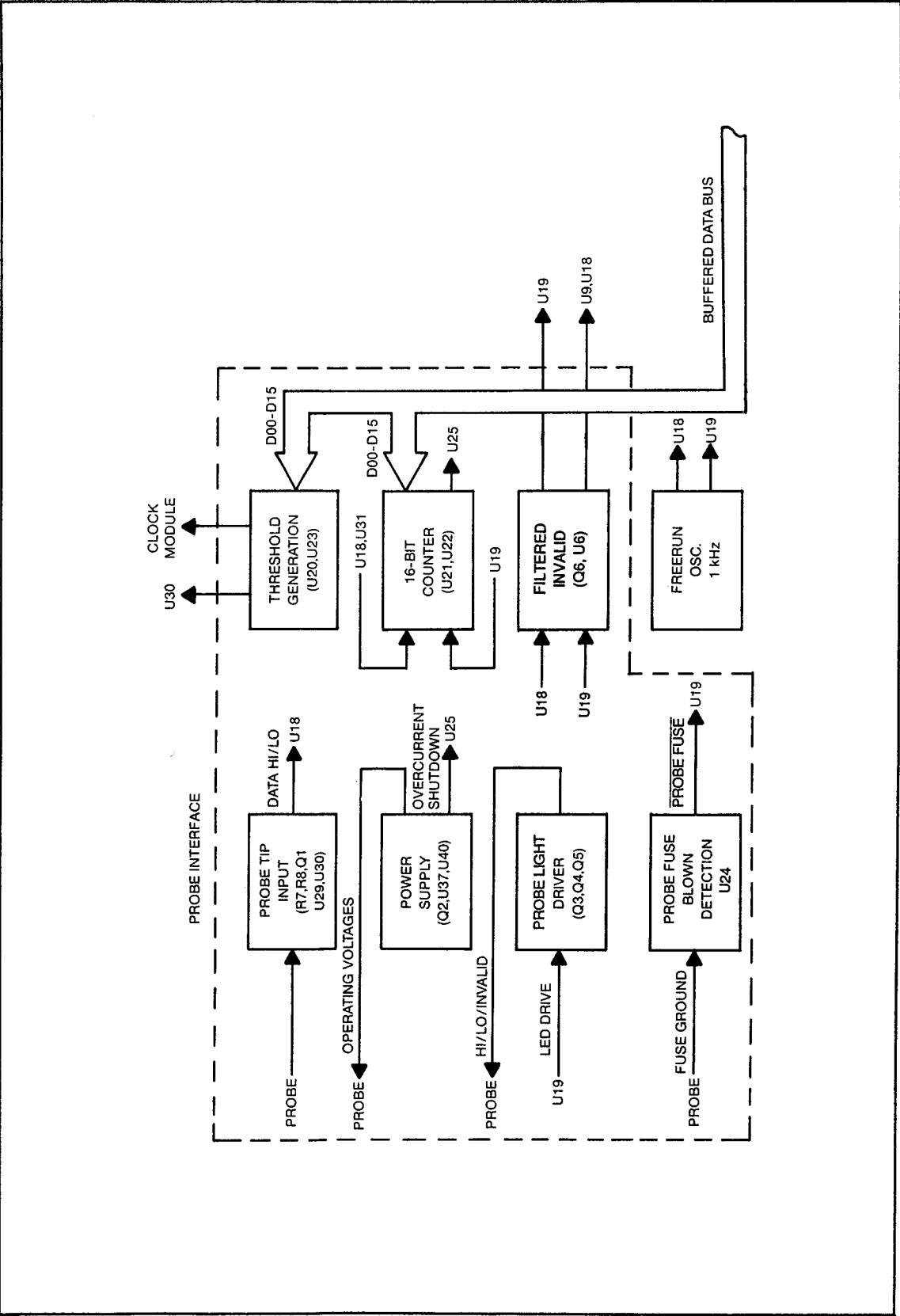

Figure 3-5. Probe I/O Interface Block Diagram (cont)

3/Theory of Operation

Probe I/O Module Interface Addressing

The 9100A/9105A allocates two 64K blocks of address space for the Probe and I/O Module system. The address space for the Probe, 0C0000 through 0CFFFF, is selected by PS4- (Peripheral Select 4). The four strobe signals PS4-, UDS- (Upper Data Strobe), LDS- (Lower Data Strobe), and NDS- (New Data Strobe) are gated by NAND gates (U7) to produce an active low enable input for each of the two 1-of-4 Decoder/Demultiplexers (U8). Address bits A11 and A12 are used as the address inputs to U8 to produce Upper and Lower Probe Bank chip select signals. The Upper Probe Bank contains address locations for U18 internal registers, high threshold D/A converter (U23), Stop Counter data and the Pulse Counter (U21, U22). The Lower Probe Bank contains address locations for the Probe Custom Logic chip internal registers, low threshold D/A converter (U20), control register (U17), and the status register (U25). The address map for the Probe I/O Module Interface is located in Table 3-19.

Table 3-19. Probe I/O Module Interface Address Map

ADDRESS	WIDTH	COMPONENT	R/W-
C000x-	(even bytes) (0 through 6)	Probe Delay Chip	(Read/Write)
C000x	(odd bytes) (1 through F)	Probe Logic Chip	(Read/Write)
C0800	(byte)	High Threshold D/A Converter	(Write)
C0801	(byte)	Low Threshold D/A	(Write)
C1000	(word)	External Stop Counter	(Write)
C1001	(byte)	Status Register	(Read)
C1800	(word)	16-bit External Counter	(Read)
C1800	(byte)	Clear External Counter and Delay	(Write)
C1801	(byte)	Chip Latched Registers Control Register	(Write)

Probe Interface

The Probe Interface group block in Figure 3-5 contains smaller specific blocks that contain circuitry for the following:

- o Controlling data input by the Probe.
- o Generating voltages used by the Probe.
- o Controlling and driving the Probe lights.
- o Detecting blown probe fuse.
- o Counting frequency, transitions, or periods with bit counters.

PROBE DATA INPUT

The signal from the Probe tip passes through a resistor divider network on the single-point Probe PCA and the Probe I/O Module PCA. A FET (Q1) buffers the signal before high-speed dual comparator U30 samples the signal. The comparator thresholds are set by programmable digital-to-analog converters (DACs) U20 and U23. The low DAC (U20) generates the low threshold by receiving input data on D00 through D07 from the buffered data bus; the high DAC (U23) generates the high threshold from D08 through D15 of the same bus. The probe data input threshold voltages can be set in 10 millivolt increments by the DACs. The outputs of U30 are converted from ECL (Emitter-Couple Logic) levels to TTL levels before entering the Custom Gate Array Delay Chip (U18).

If the Probe I/O PCA is repaired or replaced, a probe offset calibration is required. This calibration value is stored in an EEPROM on the Main PCA. Any offsets in the FET (Q1) are corrected by adding the calibration value to the U20 and U23 voltage.

THRESHOLD VOLTAGE CALCULATION

The following paragraphs describe how voltages on the Probe I/O PCA and Probe PCA determine the input voltages to U30 and output voltages of U20 and U23. The calculated results aid the technician in determining if the pca components are operating properly. The example below determines U30 output and U20 and U23 input voltages.

STEP 1: Calculation of U20 and U23 multiplier.

A. Attenuation from probe input to U30.

$$a = R8/(R8 + R_{SERIES}) = 15K/(15K + 100370) = .130$$

R_{SERIES} = probe series resistance

B. Attenuation from U20 and U23 to U30

$$b = R51/(R51 + R50) = 511/(511 + 1150) = .307$$

C. $a/b = .130/.307 = .42$

STEP 2: Calculation of U20 and U23 output voltage. (TTL level)

LOGIC LEVEL	REAL THRESHOLD VOLTAGE		U20 AND U23 OUTPUT VOLTAGE
Hi	2.4V	* .42 =	1.00V
Lo	2.8V	* .42 =	0.33V

STEP 3: Calculation of U30 input voltage.

LOGIC LEVEL	U20 AND U23 OUTPUT VOLTAGE		U30 INPUT VOLTAGE
Hi	1.00V	* .307 =	.307V
Lo	.33V	* .307 =	.101V

3/Theory of Operation

Three choices of probe input threshold are available to the user: TTL, CMOS, and RS-232. To generate a negative threshold from U20 in RS-232 applications, the software sets a bit in the probe custom logic chip (U19) to set the RS-232- signal active. This signal is used to force a negative 3.2 volt threshold on U20. Various voltage threshold levels are presented in Table 3-20.

Table 3-20. Voltage Threshold Levels

TARGET VOLTAGES	REAL THRESHOLD VOLTAGE	DAC OUTPUT VOLTAGE	U30 INPUT VOLTAGE
TTL			
5.0V ----- Guaranteed HIGH			
2.6V ----- high or invalid	2.4 volts	1.0 volt	.31 volt
2.2V ----- Guaranteed INVALID			
1.0V ----- low or invalid	0.8 volt	0.33 volt	.10 volt
0.6V ----- Guaranteed LOW			
0.0V -----			
CMOS			
5.0V ----- Guaranteed HIGH			
3.7V ----- high or invalid	3.5 volts	1.47 volts	.45 volt
3.3V ----- Guaranteed INVALID			
1.2V ----- low or invalid	1.0 volt	0.42 volt	.13 volt
0.8V ----- Guaranteed LOW			
0.0V -----			
RS-232			
30V ----- Guaranteed HIGH			
3.2V ----- high or invalid	3.0 volts	1.26 volts	0.39 volt
2.8V ----- Guaranteed INVALID			
-2.8V ----- low or invalid	-3.0 volts	0	-0.39 volt*
-3.2V ----- Guaranteed LOW			
-30V -----			

* Pulled negative by Q8 and R60.

PROBE OPERATION VOLTAGES

Two voltage levels (regulated +5 volts and -1.2 volts) are produced on the Probe I/O Interface PCA. The +5 volts is used for the Pulse High probe signal and as power for U1. The +12VN (nonregulated) voltage is converted to +5 volts by a +5 volt regulator (U40). Voltage comparator U37 acts as an overcurrent shutdown sensor for the +5 volt supply. A -1.2 volt power supply (Q2) converts -5 volts to -1.2 volts used to produce Pulse Low for the Probe.

FUSE BLOWN DETECTION

Fuse blown detection circuitry for the Probe is located between the probe connector and the Probe Custom Chip. The probe ground fuse (F1), located on the Probe I/O Interface, protects circuitry in case the user incorrectly connects the ground clip to a power supply. Detection for blown fuses is generated by two LM339 voltage comparators (U24) that generate the output Fuse-P.

PROBE LIGHT DRIVE AND CONTROL

The Probe Light Control block contains a 2:1 Line Multiplexer (U9), and a 4-bit Data Latch (U31). The 2:1 Line Multiplexer selects latched/unlatched data. Invalid asynchronous data is filtered by the Filtered Invalid block, which requires that the invalid signal persist for 100 ns before being detected. Synchronous data invalid levels are taken as is on the clock edge. The output of the Filter block is multiplexed with the invalid signal from U31 to become INVALID IN at U19-58 along with the High and Low outputs of U9. The HI IN, INV IN, and LO IN pulses are stretched 50 ms internally within U19 to become the light drive inputs to Q3, Q4, and Q5.

The three transistors Q3, Q4, and Q5 drive the three logic level indicator lights on the Probe. Each transistor drives one light:

- o Q3 for the (green) low logic level light.
- o Q4 for the (yellow) invalid logic level light.
- o Q5 for the (red) high logic level light.

The input signals to the transistors originate from U19-28, U19-29, and U19-30.

EXTERNAL 16-BIT COUNTER

Two 8-bit binary counters (U21, U22) are cascaded together to form a 16-bit external counter. The 16-bit counter together with a 8-bit internal counter of U19 combine into a 24-bit counter. The 24-bit counter counts transition changes, clock frequency counts, and period counts from data collected by the probe tip.

3/Theory of Operation

Clock Module Interface

The Clock Module Interface on the Probe I/O Module Interface PCA contains a Quad ECL-TTL Translator (U28), a Dual 4:1 Line Multiplexer (U16), and a fuse blown detection circuit. The START/START-, STOP/STOP-, ENABLE/ENABLE-, and EXT CLK/EXT CLK- signal lines are ECL (Emitter-Coupled Logic) level outputs of the Clock Module. These outputs are converted to TTL level signals before being introduced to U19. Before entering U19, the ENABLE/ENABLE-, SYNC, EN1, and ENO signals are combined to form a multiplexed input line to U19-24 via U16 for the purpose of selecting an External Enable. A blown Clock Module fuse detection circuit signals to the mainframe that a Clock Module fuse is blown. Two voltage comparators (U24) detect the blown fuse and generate the blown fuse signal (FUSE-C) to U19.

Custom Delay Chip

The Custom Delay Chip (U18) is one of two Probe Control chips on the Probe I/O Module Interface PCA. The functional block located on Figure 3-5 contains internal components dealing with Probe Input Signal Delay. The function of U18 is to produce high, low, and invalid data signals including CRC data and CRC clock generation. These signals are sent to support chips and to the Custom Probe Logic Chip (U19).

The Delay Chip contains a data multiplexer that can select either the Probe threshold or a presently unused current input U18-5. A FREERUN signal (a 1-kHz continuous square wave) and a input clock is used for internal calibration. The CURRENT input is for future expansion purposes. Once data is past the multiplexer, two separate data paths form the DATA HIGH, the DATA LOW, and INVALID OUT outputs. The Enable Clock U18-19 has a 60 ns delay switchable in or out (0 delay or 60 ns delay). A history and CRC data latch contained in U18 provides valid data (high or low) or the last valid data input for the CRC register in U19.

Functions of U18 include:

- o Delaying data high and low from the probe tip input for U31 and U9 to interpret.
- o Latching synchronous/asynchronous Hi, Lo, and Invalid Probe Data.
- o Generating CRC clock and CRC data signals used by U19 from Enable Clock input.
- o Generating INVOUT signal output at U18-34.
- o Qualifying CRC Clock Data, either present data or last valid data.

An Invalid signal, which amounts to a lack of valid high or valid low, is generated by the custom delay chip as the INVOUT signal. This is routed through a filter (U6 and associated resistor/diode arrays); the resulting output is termed Filtered Invalid. In asynchronous mode, the invalid pulse must exceed 100 ns in width. This is accomplished by using

an RC network to delay the trip point of U6, pin 1 by 100 ns. An invalid input exceeding 100 ns trips this circuit, producing the filtered invalid output. In asynchronous mode, this output is used by both the internal latches and the probe light circuitry. For the RS-232 threshold, Q6 is used to switch in C34, increasing the RC timing and producing a longer filter time of about 2000 ns for the invalid signal. The RS-232- signal from U19 is also used to pull the U20 logic level negative through level shifters Q7 and Q8.

Synchronous invalid constitutes an absence of a valid low or valid high at the clock time.

For accurate probe operation, the delays in the probe system must be calibrated. Before delay calibration can be performed, the software must determine the amount of delay per tap on the delay line internal to the custom delay chip (U18). At power-up or reset, an external 32 MHz clock signal is routed through both the high and low data paths. By choosing differing amounts of delay and counting clock edges, the software is able to compute the amount of delay per internal delay line tap. This data is saved for use in delay calibration.

The clock delay (60 ns) is switched in for negative delays, and the data delay is switched in for positive delays. Calibration is accomplished by adding delays and reading the pca's history latches. Note that any change in the external lights during this process results from pulses being fed through related circuits and has no other significance.

The delay calibration value is computed by the probe calibration procedure. Both the Clock Module and the Probe are used during the procedure, with the Probe tip being pulsed to generate the calibrating clock signal. Delays are adjusted until both the clock (probe tip pulse) and the data arrive at the history latch at the same time. The delay value derived is saved in memory and can then be stored on disk for subsequent use.

Custom Logic Chip

The second of two custom chips on the Probe I/O Module, the Probe Custom Chip, is located on the functional block diagram Figure 3-5. Internal structure and the functions of U19 deal with Probe Data signals, Probe Light drive, counting events, and clock selection. The Custom Logic chip contains the following internal structures:

- o Digital Pulse stretcher circuitry for Probe Lights.
- o A counter configurable for frequency, period, or transition.
- o Pulser control logic.
- o A CRC register circuit.
- o Start_stop_enable logic for the clock.
- o A multiplexer to select the clock.

3/Theory of Operation

The Custom Logic Chip supports functions from both the Probe and the Clock Module with different clock-type selection (Pod SYNC, FREERUN, and EXT CLK) determined within U19. CRC data is also calculated by U19.

Predetermined synchronous or asynchronous data selected by the 2:1 Line Multiplexer (U9) on the Hi in, Invalid in, and Lo in signal lines are stretched by U19 to at least 50 ms. The stretched signals become the three light drives for Q3, Q4, Q5.

An 8-bit internal counter (U19) and a 16-bit external counter (U21, U22) perform three counting modes: transition, frequency, and period. These functions count either data high transitions or 8 MHz clock transitions and are controlled as described below:

- o Transition Mode: The counter counts data transitions with a software controlled start/stop.
- o Frequency Mode: The counter counts the data transitions for a 50-ms period. The software converts this count to frequency by multiplying the count by 20.
- o Period Mode: The counter counts the 8-MHz clock from one data high transition to another. The software uses this mode to measure low frequencies, converting the count from period to frequency for display.

CRC data is gathered at the internal CRC register (part of U19). The CRC uses the delayed data and clock signals from U18.

PULSE HI and LO signals for the Probe are generated by U19 to stimulate signal lines in the UUT. To produce pulser signals, a logic low from an internal clock logic register plus a Hi, Lo, or software-generated clock enter a pulse logic register. The two outputs of the pulse logic register are the PHI and PLO signals on U19, pins 10 and 26, respectively.

The Probe Logic Chip contains an internal selection system to provide the enabled clock for U18 and the 16-bit Stop Counter, and to provide a SYNC Pulse to an externally-connected oscilloscope via a BNC connector located on the mainframe back panel. EXT START and EXT STOP from the Clock Module, and STOPCNT- are combined to enable the internal clock signal input to the internal Clock Logic Register of U19. The selected enable, SYNC-, FREERUN, and EXT CLOCK from the Clock Module combine to enable the internal Clock Logic Register, which generates the enabled clock outputs CCLK and CCLK-.

When the probe/pulser is active, the internal clock logic requires the opposite edge of the pulse to start the clock; in a non-pulsing condition, the clock starts on the first selected edge to provide an edge (before the clock edge) to start the probe output pulse. The clock is inverted internally in U19 when the pulser is active. The CSEL output is high when the clock has been inverted internally, forcing pins 3 and 6 of U2 to invert the clock outputs again to provide the correct signals to U18 and the sync output.

Stop Counter

The Stop Counter is a series of four presettable 4-bit binary up/down counters (U26, U32, U33, U34). Each counter has four parallel data inputs to count the total 16 data bus lines. STOPCTCK (Stop Count Clock) from U2-6 is the clock pulse for the counter chips. The STOPCTLD- (Stop Count Load) input to U26 (U32-, U33-, and U34-generated from U13-11) overrides counting and loads the data present on the parallel data lines into the counter. Each counter chip has a maximum count output that is gated by U38. When all of the counters reach maximum count, the output from U38 puts an active low on the data input of a dual D-type flip-flop (U10). U10 then provides the STOPCNT- input for U19-20 on the next clock pulse. RDMISC- (Read Miscellaneous) from U11-8 enables the U25-10 output, which is bit 1 of the Status Register, to read the status of the Stop Counter. The Stop Counter is programmable for 1 to 64K counts and is used to control SYNC history latches and CRC registers.

I/O Module Interface Connector

The I/O Module Interface Block located on the Probe I/O Module Interface PCA, shown in Figure 3-5 of the functional block diagram, contains three parts.

- o The connector and related components for the I/O Connector PCA connector.
- o The -VDRV Regulator for the I/O Module Pattern Drive.
- o The Overcurrent Detection Circuitry for the I/O Module Pattern Drive.

The I/O Connector PCA Connector interfaces data lines D00 through D15, address lines A01 through A12, and control lines between the I/O Module and the mainframe.

The 16 data lines from the I/O Connector PCA to the Probe I/O Module Interface PCA connect to the uP Data Bus with the low eight data bits direction controlled by an Octal Bus Transceiver (U39). The transceiver's data flow direction is controlled by an RDSL (Read Select) signal generated from PS5-, LDS-, and READ-. The upper eight data bits are unused. The address lines and four control lines (R/W- (Read/Write), FGATE (Frequency Gate), ODRESET (Over Drive Reset), and SEL- (Select)) are buffered by line drivers to maintain signal levels for communication with the I/O Modules and the I/O Connector PCA. The STROBE signal is generated for the I/O Modules by gating NDS- (New Data Strobe) with PS5- (Peripheral Select 5). The STROBE signal is sent to the I/O Connector PCA for further processing before reaching the I/O Module. Outputs from the I/O Module include the two interrupts DCE and IOGEN. The sense + and sense - signals are sourced from the +VDRV voltage regulator on the I/O Connector PCA.

3/Theory of Operation

I/O MODULE -VDRV VOLTAGE REGULATOR

This regulator provides a -0.85V output with a high short term current sinking ability (greater than 2A) and a long term current sinking capability of 250 mA . Overload detection is also provided. Figure 3-6 presents a simplified schematic of the -VDRV Voltage Regulator.

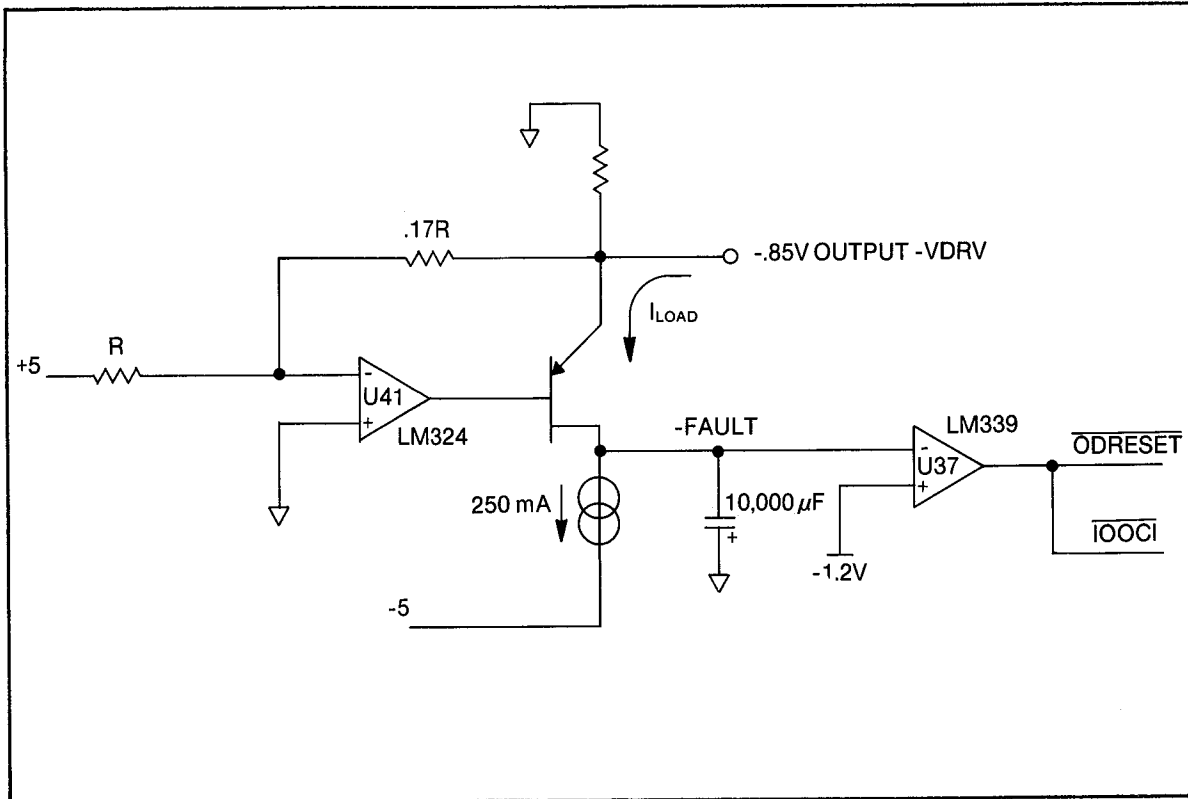

Figure 3-6. -VDRV Voltage Regulator Simplified Schematic

The regulator uses an inverting op amp circuit. With a gain of -0.17 , the op amp provides -0.85V output from the 5V input. The PNP power transistor (implemented as PNP/NPN compound Q9/Q10) is configured as an emitter follower and is used to provide increased current sinking capability. The collector supply is a 250 mA constant current sink. Dual Diode CR10 is used to return feedback to U41 and to clamp U41's output during low current situations.

When the current demand is low (less than 250 mA), the current sink saturates, and the -FAULT signal is at about -4.5V . If a high current transient appears, the current sink (Q11 and part of op amp U41) turns on, and 250 mA flows into the -5V supply. The rest of the current flows into the $10,000\text{ }\mu\text{F}$ capacitor, slowly charging it up. Because this capacitor is in the collector circuit of the power transistor, the regulator's output remains unaffected while this voltage is rising. If the current demand is high enough or long enough, the capacitor charges to above -1.2V . At this level, the LM339 comparator trips, generating an

IOOCI- interrupt and forcing the control line ODRESET- low. This in turn shuts off the I/O module overdrivers, limiting the current. The time constants of the circuit are set so that 2A can be sunk for 10 ms without affecting the regulated -VDRV output or generating an overcurrent fault.

I/O MODULE OVERCURRENT DETECTION

I/O Module overcurrent conditions are detected from either of two sources: the +VDRV supply or the -VDRV supply. The +VDRV regulator is situated on the I/O Connector PCB. Current sense from that supply is provided via the sense+ and sense- signals, which are differentially amplified by a section of U41 and compared by a section of comparator U37 to a reference. This reference is switchable, via the LO-CURRENT- line, to one of two settings. The low setting, commanded when LO-CURRENT- is low, sets a reference of about .4V, which in turn sets an effective current limit of about 200mA. The high setting sets the reference to about 4V, which sets the current limit to about 2A. This high current setting is guaranteed by software to never be active for more than 10 ms, (with a max duty cycle of 1%). R73, C18, and CR12 slow down the output of the differential amplifier so that it does not trip on transients.

A -VDRV overcurrent condition is detected by another section of the U37 comparator. These two comparators are "wire ORed" together. If either one detects a fault, both of their outputs goes low. This fault causes the ODRESET- line to go low, which turns off the I/O Module overdrivers, thus removing the overcurrent fault. At the same time, flip-flop U27 is clocked, making IOOCI- go active and generating an interrupt. This interrupt can be cleared by writing line IOCLRINT- low; (WRITE @ C1801: bit 1 = 1 says clear interrupt; bit 1 = 0 says release interrupt).

Miscellaneous Functional Blocks

The Probe I/O Module Interface PCA has two functional blocks for the specific purpose of interfacing with external equipment: the SYNC Pulse Isolation block and the Footswitch Connector (J4). Two other functional blocks (Data Bus Buffers, Status Register, and Control Register) support operations for probe control.

SYNC PULSE ISOLATION

SYNC Pulse Isolation uses an optoisolator and an earth-referenced divider to provide an earth-referenced TTL level SYNC Pulse (isolated from the 9100A/9105A) to an oscilloscope. Inputs to this block include an earth referenced +5 volts and a clock pulse from U2-6. The resulting external trigger output is available at a BNC connector on the rear panel.

3/Theory of Operation

FOOTSWITCH CONNECTOR

The Footswitch Connector (J5) is a standard telephone jack that connects to a normally open switch. The switch is used as an external event recognizer. A test program can use such a switch to make a program depend on an external event, a manually generated signal, or a limit. Access to J5 is on the right side of the mainframe labeled (EXT SW). A switch closure is detected by the COLUMN9 and ROW7 signals; these signals are sourced from the keypad scanning circuitry on the Display PCA.

DATA BUS BUFFERS

Data Bus Buffers (U35, U36) permit data transfer from the microprocessor data bus to a buffered data bus. Instructions from the microprocessor to the ICs on the Probe I/O Module Interface PCA move along the microprocessor data bus through J6 to U35 and U36. The data moves through the Data Buffers onto the buffered data bus to the required ICs.

STATUS REGISTER

The Status Register (U25) monitors single data bits on the Buffered Data Bus to detect I/O Overcurrent Interrupts, Probe Power, Stop Counter Status, and Pulse-Transition Counter Carry-Bit Status. The Status Register is a quad 3-state buffer (U25) connected to the output of the circuit and the data bus. U25 is read only, and Figure 3-7 summarizes the status bits. The Status Register output to the data bus is enabled by the RDMISC- (Read Miscellaneous) signal from U11, pin 8.

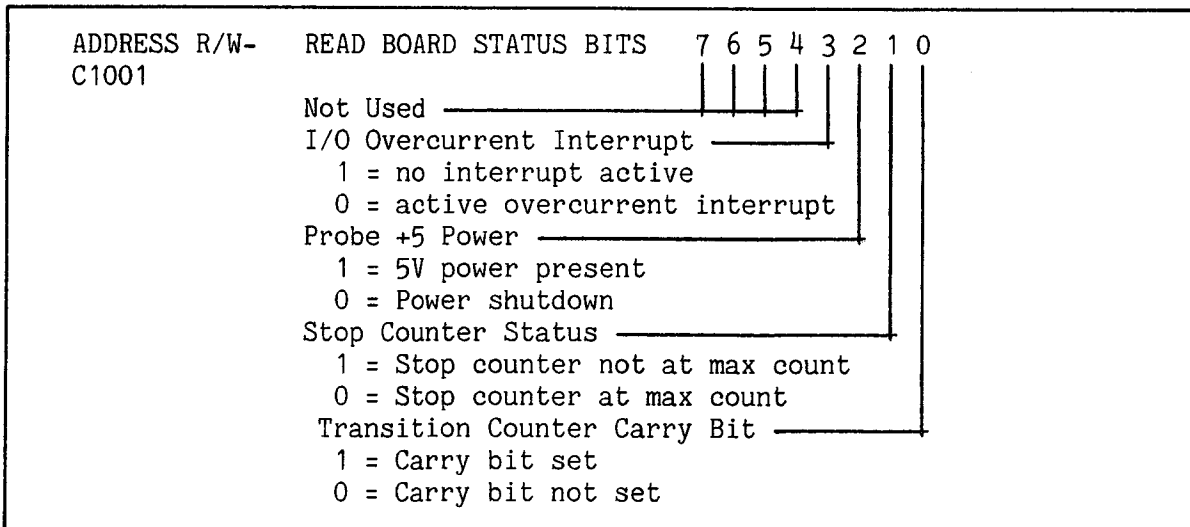

Figure 3-7. Status Register Bit Breakdown

CONTROL REGISTER

A 4-bit Write-Only Control Register (U17) generates the STOPCTENA- (Stop Counter Enable), IOCLRINT- (IO Clear Interrupt), EN0 (Enable 0), and EN1 (Enable 1). The Control Register decodes data bits 00 through 03 of the Buffered Data Bus to generate the output signals. Data bits 02 through 03 determine different ENABLE combinations. Data bit 01 either clears or allows an I/O Overcurrent Interrupt, and data bit 00 enables or disables the Stop Counter. Figure 3-8 represents the data bit breakdown for the Control Register.

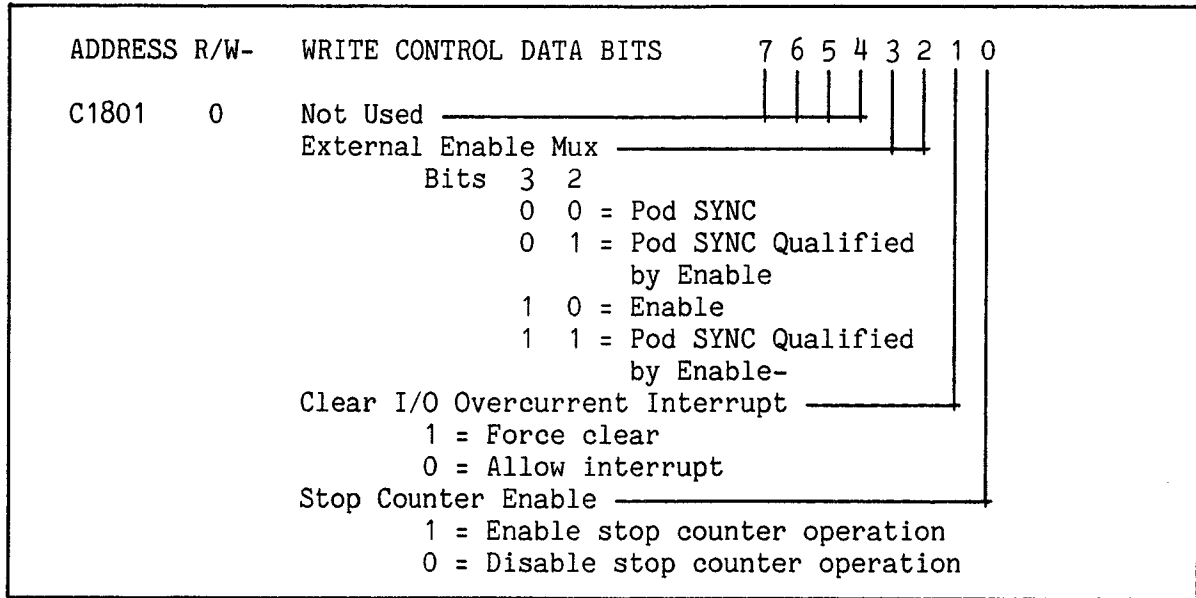

Figure 3-8. Control Register Bit Breakdown

I/O CONNECTOR INTERFACE

Overview

The I/O Module Connector PCA provides the interface for the I/O Module to the 9100A/9105A. The I/O Connector Interface shown in Figures 3-1 and 3-2 is a vertically-mounted PCA that plugs into the Probe I/O Module Interface PCA, which connects to the Main PCA. Up to four I/O Modules can be connected to the 9100A/9105A. The I/O Connector and the Probe I/O Interface PCAs buffer the 68000 microprocessor address and data bus to send data out to the modules. The PCAs also contain the I/O Module overdriver power supplies and circuitry to gather and distribute control, data, and address signals, event detection, and operational power for each I/O Module.

3/Theory of Operation

Power Supplies

There are two power supplies for the I/O Module, one at 5V, (called +VDRV), and one at -0.85V (called -VDRV.) The +VDRV power supply is a linear supply derived from the +12V supply. Current is sensed by measuring the voltage across the .47 ohm resistor. This voltage is measured on the Probe I/O PCA from the SENSE +/- lines.

Gross overcurrent protection is provided by an LM338 voltage regulator (U4). Normal overcurrent protection is provided via an overdriver shutdown line, (ODRESET-). This line instantly turns off the overdrivers, removing the overcurrent fault. An overcurrent fault is triggered if current exceeds two programmable levels: 200 mA, and 2A. The 200 mA level is the power-up default, and is only changed to the higher level during pattern drive. The 2A level is a short term (10 ms 1% duty cycle) maximum amount of current for all four I/O Modules. The overcurrent level is controlled by the (LO CURRENT) control line produced by DTIO #2 (U7) on the Main PCA. If the 200 mA and 2A thresholds are violated, an I/O Overcurrent Interrupt (IOOCI) is generated. Simultaneously, all of the overdrivers on all of the I/O Modules are shut off.

The 10,000 uF capacitor is part of the -VDRV regulator, which is covered in the Probe I/O Module Interface discussion.

I/O Module Connector PCA Contents

The I/O Connector PCA contains four DB-37 vertically-mounted connectors that are accessible on the rear panel of the mainframe. On the other side of the PCA is a voltage regulator (U4) with supporting capacitors (.01 uF, 1000 uF), and the 10,000 uF capacitor used in the -VDRV regulator. The connector to the Probe I/O PCA (J1) supplies all I/O Module power, event detection, address, data, and control signals to the I/O Module.

The address bus containing A01 through A11 and the data bus containing D00 through D07 distribute address and data lines to each connector with A08 through A11 used to determine the +/- STROBE for the selected I/O Module. When the STROBE signal is divided between each module connector, the signal has PS5 and "hot bits" decoded in the signal. The Pod +/- SYNC signal used for timing with the Probe and I/O Module is also distributed to the four I/O connectors by a quad ECL-TTL translator (U2).

The DCE- and IOGEN- interrupts from each module are input to a dual 4-input NAND gate (U3). The outputs of U3 are connected to J1 and sent to the mainframe for further processing. The MODSEL- line is connected through jumper J8 to IWAIT3-. This forces I/O Module bus communications to occur with three wait states, allowing for reliable bus operation over long cable lengths.

PROBE/PULSER

Overview

The Single-Point Probe/Pulser is a 9100A/9105A interface device used to measure portions of the UUT PCA not accessible to the I/O Module. The Probe/Pulser measures inputs up to 40 MHz and generates stimulus pulses at up to a 50 kHz rate. A 1-bit-wide data channel provides input measurement and output stimulus capabilities. Features available through use of the Probe/Pulser include: 16-bit cyclic redundancy checks (CRC), clocked and asynchronous level history, and frequency measurements. The Probe/Pulser instrument is divided into four functional blocks:

- o Sensing Block (Probe)
- o Pulsing Block (Pulser)
- o Level Indicator Block (Lights)
- o Switch Block (Switch)

Refer to Figure 3-9 for the functional block diagram of the Probe/Pulser.

Probe

The Probe measures signals from the UUT, with the Probe tip making a single-point connection on the UUT board. The UUT signal is routed through Probe circuitry and the Probe cable to the 15-pin Probe connector on the right side of the mainframe. The Probe functional block contains both the common ground and the one-bit data channel for the UUT.

PROBE TIP INPUT

Signals enter the Probe Tip, passing through R1 and R2. These two resistors in conjunction with R8 on the Probe I/O PCA form a resistor-divider compensation network to match the impedance of the Probe cable. R9 is a pull-up resistor to pull the Probe to a tri-state condition when no other inputs are connected. The input signals exit the Probe via J1-14 and enter the Probe I/O Module Interface PCA. The speed of the input signals must meet the criteria listed in Figure 3-10 to be captured by the Probe Data Channel.

3/Theory of Operation

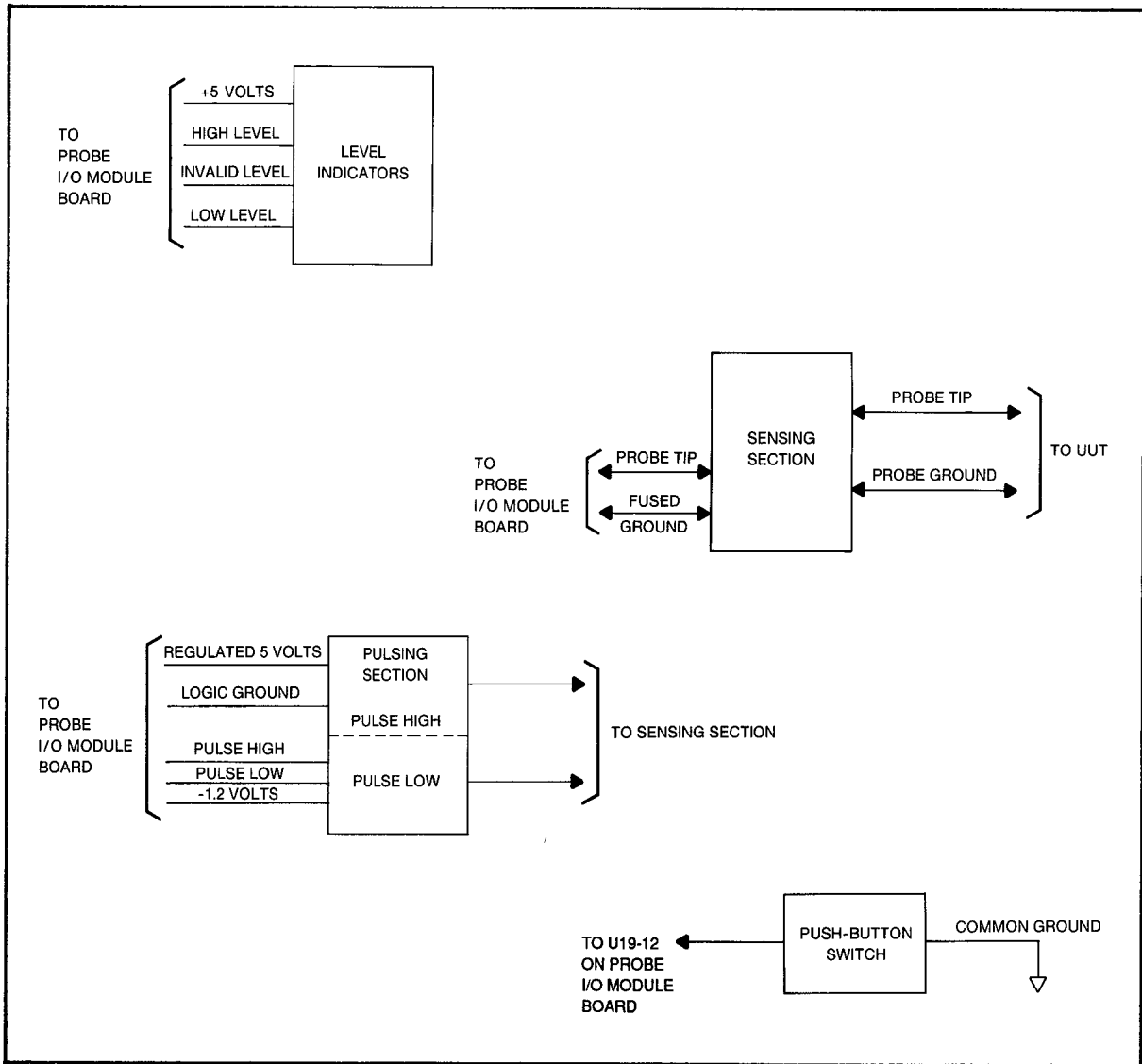

Figure 3-9. Probe/Pulser Functional Block Diagram

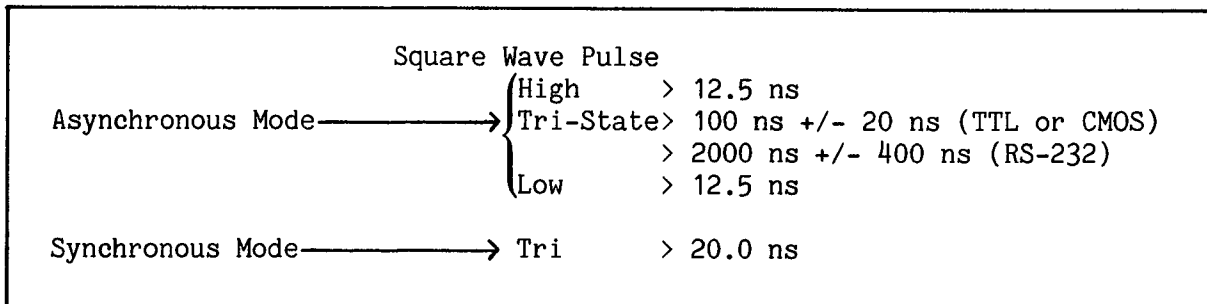

Figure 3-10. Probe Speed Specifications

COMMON GROUND CLIP

The Common Ground Clip connected to the Probe/Pulser clips to the UUT common ground. At the point where the ground connects to the Probe/Pulser, the common lead screws in to make connection. The ground line passes directly through the instrument to J1-9. If the user misconnects the Common Clip, a Probe Fuse located next to the Probe Connector on the mainframe provides protection from power supply shorts or other overcurrent conditions. The Ground Clip must be connected to the UUT to ensure a short return path for pulsing current.

Pulser

The Pulser stimulates input signals for checking output data on the UUT. The Pulser drives a short duration high current level either high or low at a node being tested. The output pulse can be toggled between High and Low or turned off completely (Tristate). During the low pulse, current is supplied by Q4. A high logic level on the PULSE LO signal line turns on Q4, driving the Probe tip low through CR4. C4 supplies instantaneous current for the low pulse. When the Pulse low signal line is off (logic low), Q3 conducts to turn off Q4 quickly. CR4 prevents the Probe tip from being pulled high at this time. The -1.2 input voltage from the Probe I/O Module (J1-13) is used to generate the low pulse.

On the PULSE HI signal line, the logic high into U1-5 inverts to a logic low to turn Q1 on, driving the probe tip high through CR1. C2 is a speed-up capacitor that drives Q1 into saturation, and C3 supplies instantaneous current for the high pulse. A logic low on the PULSE HI line turns Q1 off; Q2 is turned on, and CR1 prevents the Probe tip from being pulled low. The regulated +5-volt supply is used to generate the Pulse High signal and supplies power to U1. Both pulse levels drive the voltage at a specified current for the time shown in Table 3-21.

The Probe pulser exhibits a certain delay in reacting to the synchronous inputs. The maximum propagation timing from synchronous input to pulser action is listed in Figure 3-11.

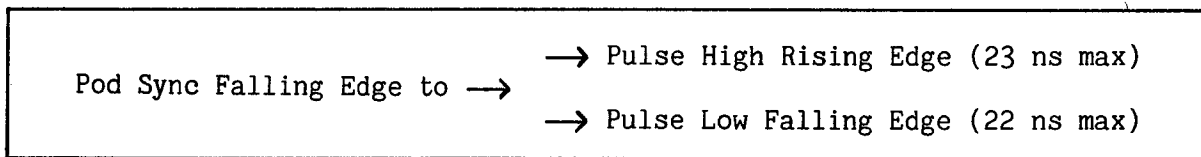

Figure. 3-11. Probe Response Timing Specifications

Table 3-21. Typical Probe Pulser Amplitude

LEVEL	VOLTAGE	CURRENT
High	> 3.5V	200 mA for less than 10 us (1% duty cycle)
	> 4.0V	5 mA continuously
Low	< .8V	200 mA for less than 10 us (1% duty cycle)
	< .4V	5 mA continuously

3/Theory of Operation

The minimum pulse widths of the Pulser are shown in Table 3-22.

Table 3-22. Pulser Pulse Width

MODE	WIDTH
Pod Sync	> 50 ns
Free Run	2 us @ 1 kHz pulse rate
External	> 50 ns

Level Indicators

There are three level indicators on the Probe. The level indicators are used to indicate what logic levels have been encountered. The indicators have the following meaning:

- o Red: A valid high signal was encountered.
- o Yellow: An invalid signal was encountered.
- o Green: A valid low signal was encountered.

The logic indicators are driven by a circuit on the Probe I/O PCA that stretches the pulses to a minimum length of 50 milliseconds.

LOGIC LEVEL MODES

The lamp logic can display either in a synchronous or asynchronous logic mode. A writable register in the Probe Custom Logic Chip on the Probe I/O PCA chooses either synchronous or asynchronous mode. The choice is hardware independent of the SYNC Mode of the CRC and other clocked latches. Asynchronous information is displayed when SYNC is set to FREERUN, and all other SYNC modes display the last synchronous data.

LEVEL INDICATOR OPERATION

The three level indicators are driven by three open-collector transistors (Q3, Q4, Q5) on the Probe I/O Module PCA. Three resistors (R11, R12, R13) are connected to the lights to maintain keep alive current flow in the off condition to increase bulb life.

Push Button Switch

A push button located on the Probe allows the user to indicate when the Probe is in place and ready to perform a "read probe". When the user presses the push button, an interrupt is generated by the Probe I/O PCA. The interrupt is shared by the fuse-monitoring circuits and thus requires that a status register in the Probe Custom Logic chip be polled to determine the origin of the interrupt.

CLOCK MODULE

Overview

The Clock Module is an external unit that is plugged into the right side of the mainframe. When used in conjunction with the Probe, the Clock Module samples external events (start, stop, clock, and enable) that are necessary in gathering signatures from the UUT to synchronize data input and output through the Probe.

Clock Module Operation

Four comparators (U1A, U1B, U2A, U2B) are used, with respective start, stop, clock, and enable input thresholds provided by the Probe I/O Module PCA. The inputs go through a divide-by-2 resistor-divider network to the comparators. The other input (0.8V) to the comparator is provided by the Probe I/O Module PCA, giving a threshold of 1.6 volts for external signals. The resulting balanced ECL signals are routed through J6 to the Probe I/O Module Interface. An external ground connection is also provided, with a user-accessible fuse (F1) protecting the circuit in case of inadvertent contact of the ground lead to the power source.

The balanced ECL signals from the Clock Module are converted to TTL level signals on the Probe I/O PCA before being introduced to the Custom Probe Logic chip (U19). A detection circuit is used to sense a blown fuse in the Clock Module. The outputs from the Clock Module are Start, Stop, Clock, and Enable. The Enable signal is multiplexed by the selection multiplexer (U16) signal lines; Pod SYNC, Enable ANDed with Pod SYNC, or inverted Enable ANDed with Pod SYNC produces the EXT ENABLE signal to U19-24.

Clock Module Speed

The clock module timing specifications listed below are valid for all signal lines into the pod.

- o Maximum Repetition Rate: 40 MHz square wave
- o Minimum Pulse Width: 12.5 ns

MULTI-FUNCTION INTERFACE

Overview

The Multi-Function Interface (MFI) PCA supports peripheral systems for use with the 9100A. A Small Computer System Interface (SCSI) and a Real Time Clock are supported as standard features for the 9100A. A version of this pca (Real Time Clock only) is optional in the 9105A.

3/Theory of Operation

Addresses

The MFI Card plugs into J6 (the MFI Card Connector) on the Main PCA. The card is allocated the address space OB0000 through OBFFFF. A PAL (U3) on the MFI Card divides the applicable address space among the installed peripheral systems. Line FC2 qualifies these addresses, allowing access only from System Mode.

Clock

The Real Time Clock consists of clock chip U9, 32.768 kHz crystal Y1, and a lithium-battery backup backup circuit centered on B1. A DTACK generator (U10) provides the extended read and write cycles required by the clock. Test point TP3 facilitates monitoring of crystal oscillator Y1. Clock U9 contains internal battery-sustained RAM. The clock is addressed through even bytes at addresses B1000 - B1020.

SCSI

The SCSI (Small Computer System Interface) is structured around a 5380 controller chip (U2 on the MFI PCA). Generally, U2 handles hardware and software interfacing between the 9100A and the SCSI bus. On the 9100A, the bus accommodates a hard disk and hard disk controller accessed through the internal SCSI connector (J2); the hard disk and SCSI circuits are not available with the 9105A. The external SCSI connector (J3) provides SCSI bus connection for additional devices. Controller chip U2 is mapped to the 16 odd addresses B1001 through B101F.

VIDEO

The separate Video Controller PCA supports the Monochrome Monitor or a color monitor. It is supplied with the 9100A Programmer's Station. The Video Controller PCA is available with the 9105A as an option. Note that the video system is character-mapped; in other words, a specific video RAM address maps into a physical location on the monitor screen.

Video Controller

The 9100A Video Controller PCA uses the 2674 Advanced Video Display Controller (AVDC), U1, along with the 2675 Color/Monochrome Attributes Controller (CMAC), U2. The 2674 (AVDC) generates the vertical and horizontal timing signals necessary for the display of data on a CRT monitor. The 2674 is programmed with terminal setup information, providing cursor, blanking, and clock signals to the CMAC. The AVDC is assigned address space OF0000 through OFFFFF. In time with horizontal (HSYNC) and vertical (VSYNC) signals, the AVDC addresses Video RAM (U3 and U4) and the Character PROM (U5) on lines DADD00 through DADD11. By using the ASCII codes supplied by the microprocessor (and stored in Video RAM) and the correct display character data stored in the Character PROM, this sequencing yields display characters.

Video RAM

U3 and U4 provide two kilobytes of static video RAM. When addressed over the main address bus (AA01 through AA10), Video RAM is used to store ASCII character codes supplied by the microprocessor over the main data bus (DB00 through DB15). Video RAM uses address space 0E0000 through 0EFFFF.

Video Control sequentially samples these addresses using lines DADD00 through DADD11 and generates display characters using the ASCII codes found at these addresses and the corresponding display character information found in the Character PROM (U5).

Video RAM is shared by both the mainframe processor and the video-generating circuitry. The ASCII codes for display characters are stored in memory at the same addresses used by the Monitor. This memory mapping allows for efficient updating of data on the CRT. Figure 3-12 demonstrates display address mapping.

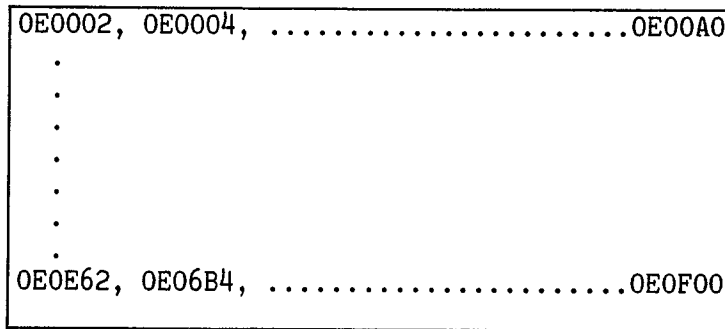

Figure 3-12. Video Display Address Mapping

The video RAM, which resides in a 4K-byte memory space, supplies 2K words for storing characters (1920 words are needed by the 24 lines by 80 characters per line). Both the microprocessor on the Main PCA and the AVDC on the Video Controller have access to video memory; the Main PCA is allowed only to write to video memory. Video control circuitry synchronizes Video and Main PCA requests for memory.

3/Theory of Operation

Each displayed character resides in one word of memory, divided into two bytes. Use of the high (or attribute) byte differs between color operation and monochrome operation. The low (or character) byte does not differ between operating modes. Figure 3-13 illustrates the overall data format.

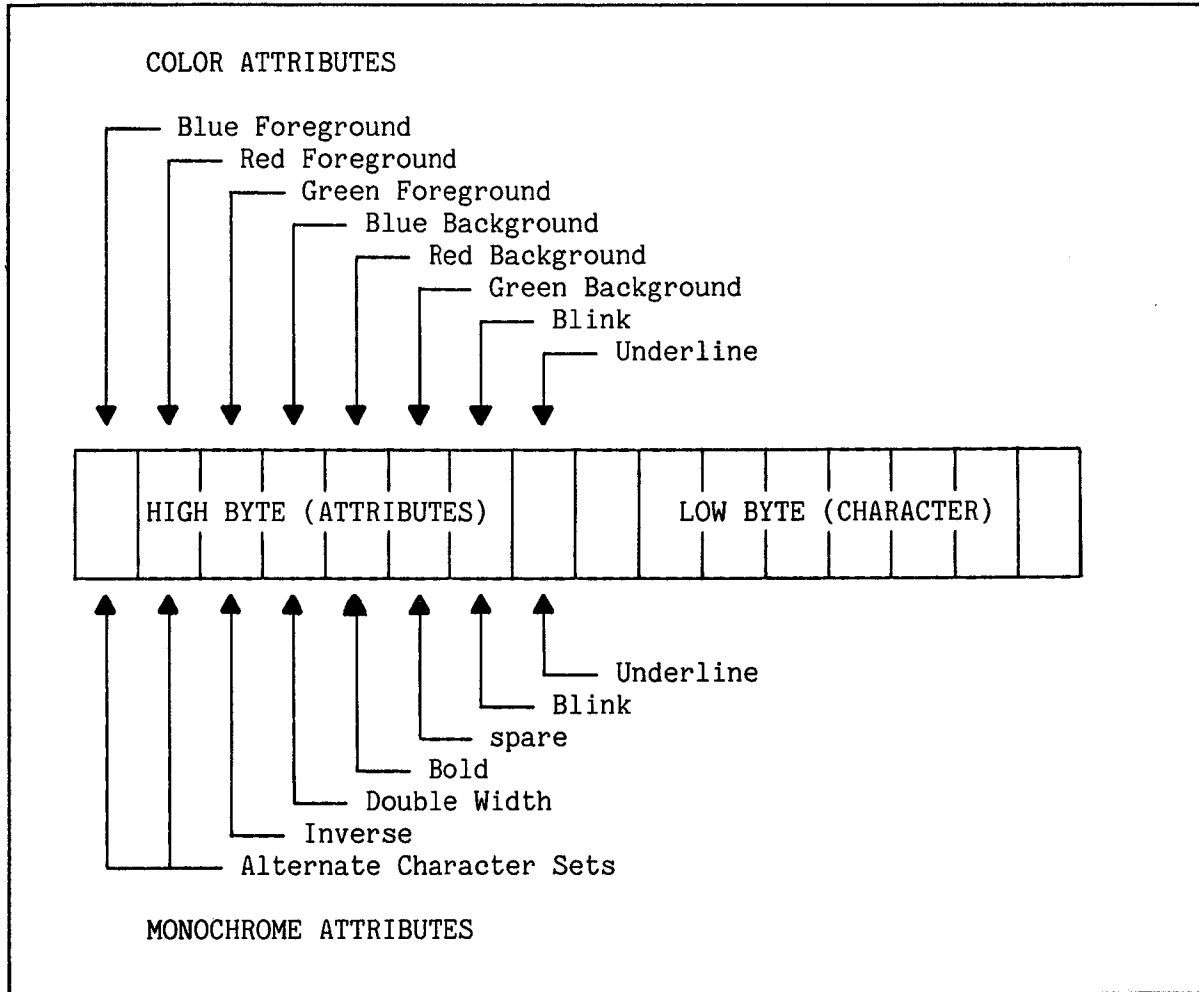

Figure 3-13. Video Character Data Format

The eight registers controlling the video display are selected by the processor using address lines A1, A2, and A3. In addition, line A4 can be high or low for register selection in color mode, but must be high for register selection in monochrome mode.

Outputs to the Monitor include horizontal and vertical sync signals (positive polarity, TTL levels) for both monochrome and color operation. Video data is output as positive white analog levels in monochrome operation or as RGB TTL levels in color operation.

The isolated output allows the mainframe to remain isolated from the earth-grounded monitor. All color and synchronization signals pass through high-speed opto-isolators (U28 - U31). For monochrome output, red and blue output channels are combined to provide high and low intensity signals. Buffer U27 sets the output voltage level, as determined by the red/blue signal intensity encoding. With a color monitor, +5V dc is provided by an earth-grounded power supply on the Main PCA. Otherwise, power from the monochrome monitor is used for enhanced noise immunity.

MONITOR

A separate Monitor can be used with the 9100A Video Controller. A 12-inch monochrome version is available from Fluke. This unit includes a power supply, a CRT, and CRT drive circuitry. Video timing functions are performed by the Video Controller and are not part of the Monitor.

The monitor power supply, which is not manufactured by Fluke, is a switch mode supply that operates from an unregulated 90 to 132V or 180 to 264V ac line voltage and generates the following regulated voltages:

- o +12V dc +/- 5%
- o -12V dc +/- 10%
- o +5.0V dc to +5.1V dc

A color monitor can also be used. See "Color Monitor Specifications" in Section 2 for either the Fluke monochrome monitor or color monitor specifications.

PROGRAMMER'S KEYBOARD

The Programmer's Keyboard is a full ASCII keyboard with additional cursor control and special function keys. Key press codes are sent at 1200 baud in a standard asynchronous format of one start bit, eight data bits (LSB to MSB), and two stop bits. The keyboard buffers up to 31 key codes, at which time the buffer will be filled and subsequent key presses are lost.

The Programmer's Keyboard attaches to the ASCII Keyboard Connector (J10) on the Main PCA. A DUART-Timer-I/O (DTIO#2), U7, provides the Main PCA interface for keyboard signals. The ASCII characters are received as the RxDA input at U7-35.

3/Theory of Operation

I/O MODULE

I/O Module Overview

The I/O Module is a device that adds multiple lines of input/output capability to the 9100A/9105A mainframe. The I/O Module has the capability to take CRCs, measure frequency or take event counts, and record logic levels. These measurements can be done simultaneously on up to 40 lines per I/O Module. It is also possible to synchronize the data gathering to the 9100A/9105A uP Pod or to external events using the I/O Module external clock, enable, start, and stop lines. In addition, the I/O Module has the ability to "overdrive" dynamic patterns or static levels onto any of its lines for use in testing devices that cannot be stimulated by the uP Pod. The I/O Module is capable of reading or writing a 40-bit word, and it provides breakpoint capability by generating an interrupt when the data on the inputs equals a programmed value. Input thresholds for each module are selectable between "TTL" and "CMOS" levels. Up to four I/O Modules may be connected to the 9100A/9105A mainframe. The I/O Module consists of seven functional blocks. See Figure 3-14 for a functional block diagram of the I/O Module.

Each of these blocks is described in more detail in the paragraphs that follow:

- o Bus Interface Functional Block
- o Custom Chip Functional Block
- o Clock and Enable Mux Functional Block
- o General Control Latch Functional Block
- o Connector Code Functional Block
- o Input Protection/FET Output Block
- o I/O Module Top PCA Functional Block

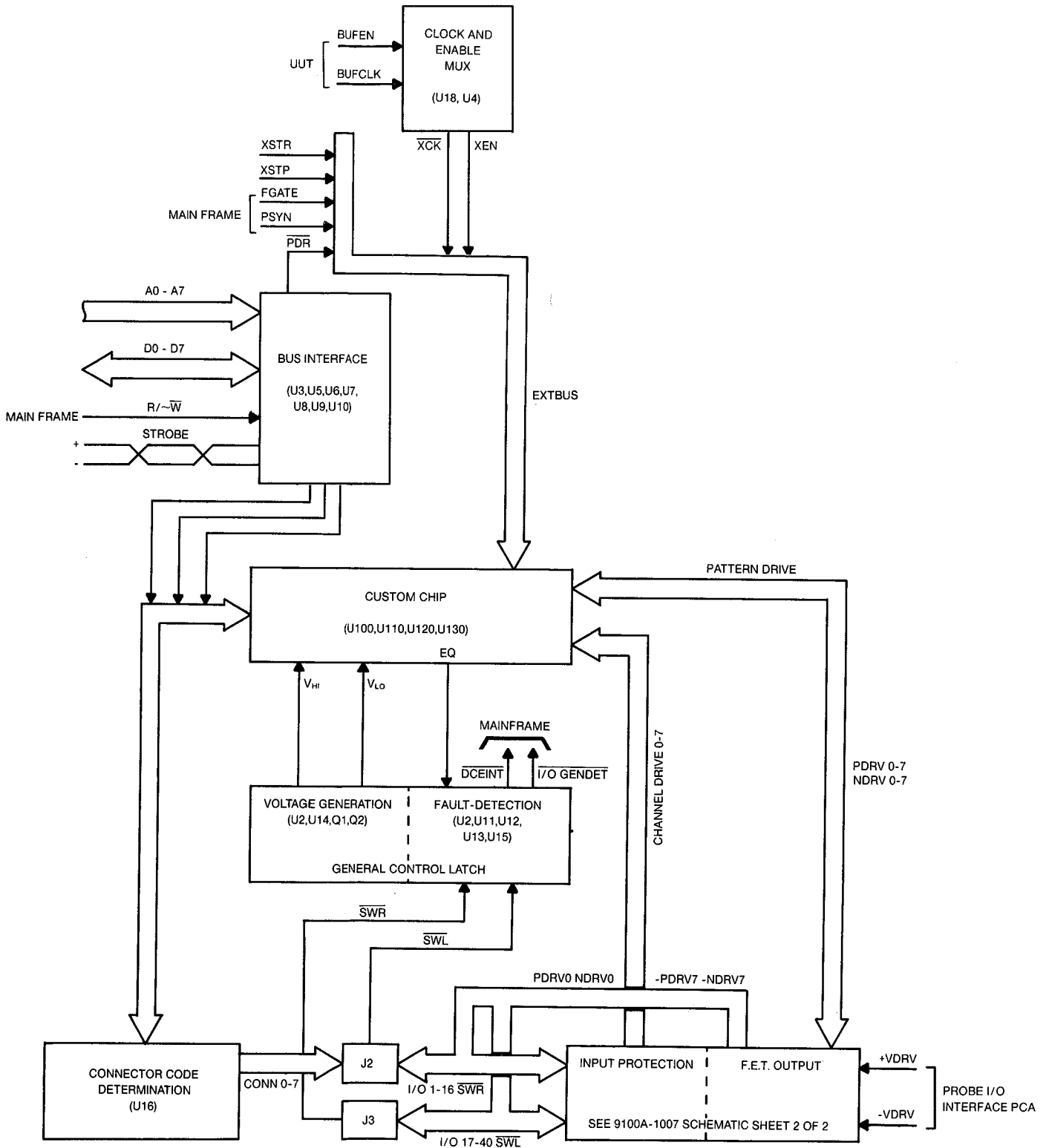

Figure 3-14. I/O Module Functional Block Diagram

3/Theory of Operation

Bus Interface Functional Block

OVERVIEW

The bus interface block connects the 9100A/9105A microprocessor bus to the I/O Module. The I/O Module is a memory-mapped device, with all control performed by writes to the I/O Module memory space. A control bus enters the I/O Module on connector J1 and consists of the following lines:

- o Seven address lines: A01 through A07
- o Eight data lines: D00 through D07
- o Two differential strobe lines: STROBE+, STROBE-
- o One control line: R/W-

The two strobe signals, which are sent up the cable on a twisted-pair as differential ECL signals, are the key to the clean bus interface. They are translated by U9 into the STROBE- signal. As sent by the mainframe, the STROBE- signal already has some amount of address decoding done in it; STROBE- for any particular module will only be active on accesses to addresses DXXXX, with A0 = 1, and with the proper "hot bit" identifying the module. (See the paragraphs on addresses for more information on hot-bit decoding). STROBE- is the key signal used to qualify all of the bus activities and is used by U7 to latch the addresses and R/W- and to enable the data bus buffer. The STROBE- signal, in conjunction with the latched version of R/W- generates the read strobe (RD-) and the write strobe (WR-). The STROBE- signal and the decoder U6 generate the chip select signals: CS0 through CS4, ADD-, and ADE-.

The following paragraphs explain how the I/O Module address is broken down and what the hex digits signify. I/O Module selection is described with a figure showing which I/O Module(s) are selected. A timing diagram shows typical waveforms during a read and write cycle. The process of enabling the I/O Module custom chip(s) is also described.

ADDRESSING

Memory reserved for I/O Module control occupies addresses D0000 through DFFFF. Out of this 64K-byte block, four I/O Modules can be addressed. Lower Data Strobe, (LDS-), is used to qualify all I/O Module addresses; thus A00 is effectively a 1. Addresses within this space using Upper Data Strobe (UDS-) are unused. Figure 3-15 shows a summary of I/O Module address decoding. Figure 3-16 provides an addressing example.

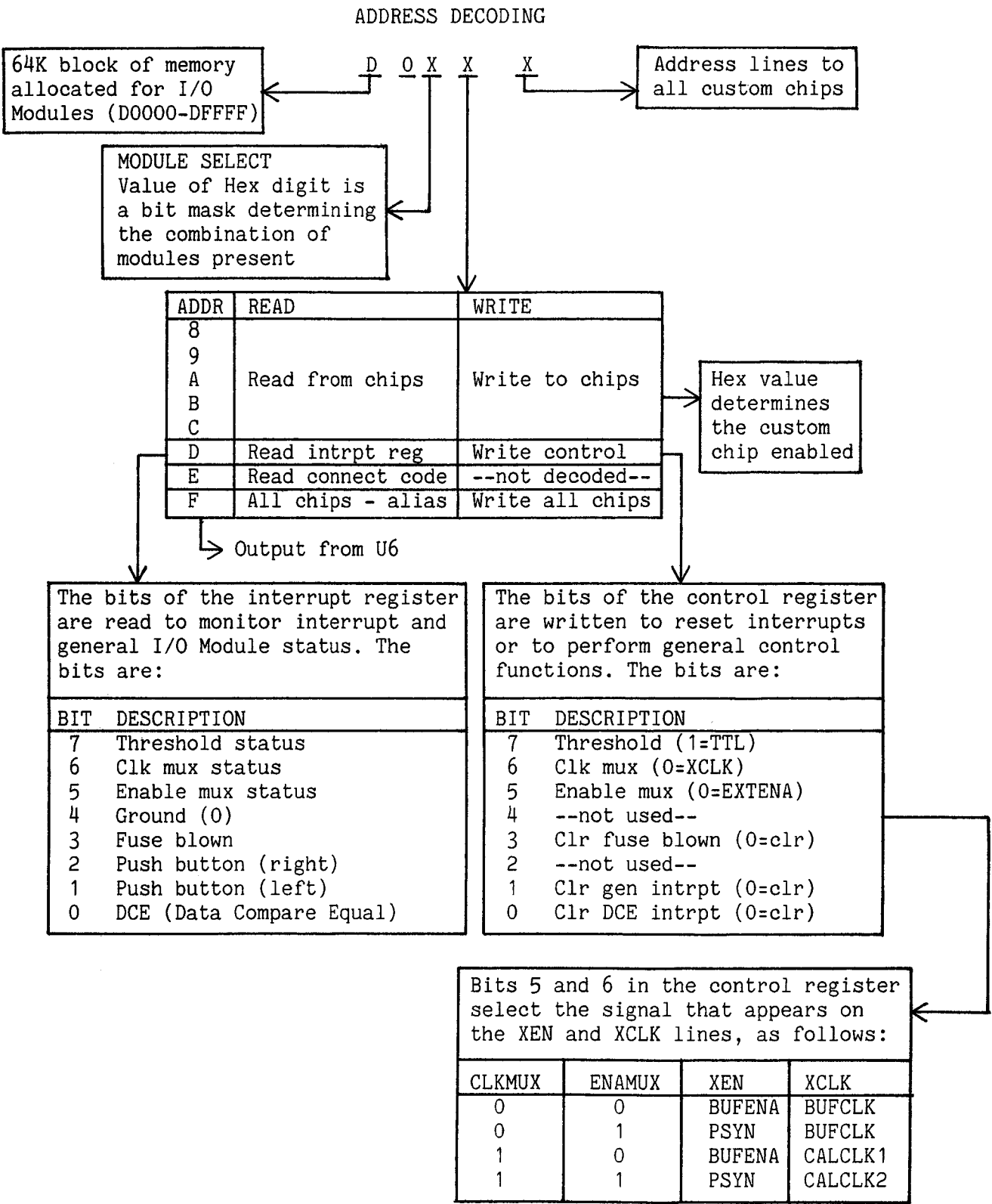

Figure 3-15. I/O Module Address Decoding Summary

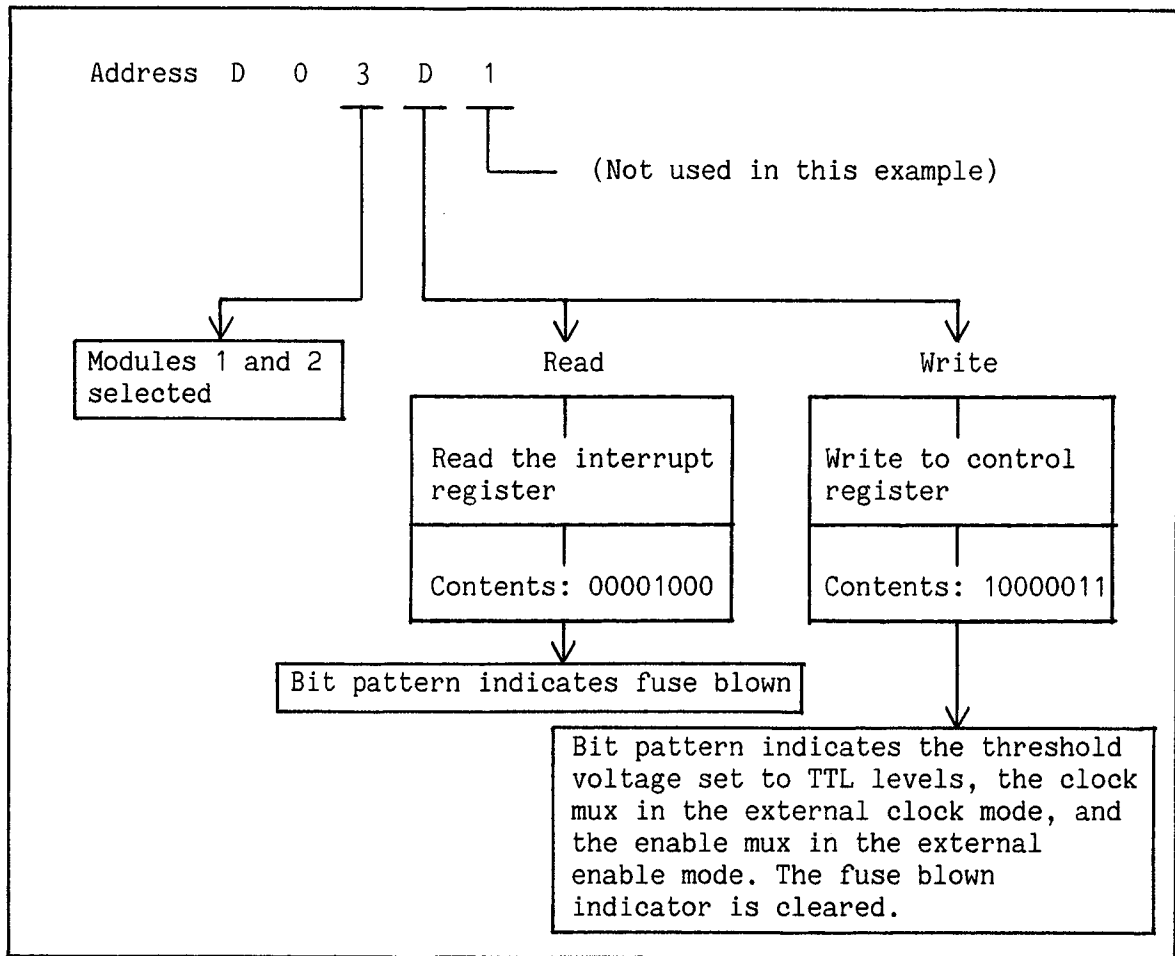

Figure 3-16. Address Decoding Example

Each of the four I/O Modules is controlled via "hot-bit decoding" of address lines A8 through A11. This method of decoding allows any combination of modules to be addressed simultaneously. A brief explanation of "hot-bit decoding" requires examination of the 5-digit hex I/O Module address. The third LSD of the address is broken down into binary form. The position of the set bit(s) determines the module(s) to be addressed. See Figure 3-17 for examples.

The timing diagram, Figure 3-18, shows the signals contained in the bus interface block during a read and write cycle. Each transition point is further explained.

- o A: Address appears on bus, and R/W- goes high signifying a read cycle.
- o B: RD- and CS- go active. Data bus transceiver U8 turns on, pointing toward the mainframe. Addresses and R/W- are latched by U7 and are guaranteed valid.
- o C: Valid read data appears on data bus.

Address	D 0 1 X X	I/O Module 1
	D 0 2 X X	I/O Module 2
	D 0 4 X X	I/O Module 3
	D 0 8 X X	I/O Module 4
	D 0 9 X X	I/O Modules 1, 4
	D 0 F X X	I/O Modules 1, 2, 3, 4
Binary Breakdown	0 0 0 1	I/O Module 1
	0 0 1 0	I/O Module 2
	0 1 0 0	I/O Module 3
	1 0 0 0	I/O Module 4
	1 0 0 1	I/O Modules 1, 4
	1 1 1 1	I/O Modules 1, 2, 3, 4

Figure 3-17. Hot-Bit Decoding Examples

- o D: STROBE-, RD-, and CS- return high. Read data guaranteed valid here.
- o E: End of read cycle.
- o F: Address appears on bus and R/W- goes low signifying a write cycle.
- o G: WR- and CS- go active. Data bus transceiver U8 turns on, pointing toward the I/O Module. Addresses and R/W- are guaranteed valid.
- o H: STROBE-, WR-, and CS- return high. Write data latched into I/O Module registers.
- o I: End of write cycle.

CUSTOM CHIP SELECTION

One use of the Bus Interface is to decode address lines A01 through A07 from the mainframe to determine which custom chips are enabled. As the address signals enter the Main I/O Module PCA through J1, the address lines are latched by U7 (the latch signal is STROBE-). Address lines A07 through A04 are used as address inputs for the decoder (U6). The outputs of U6 are gated to determine which custom chip is enabled. Any one of the five custom chips, or all five may be addressed simultaneously. Particular combinations of the custom chips are not addressed within a module.

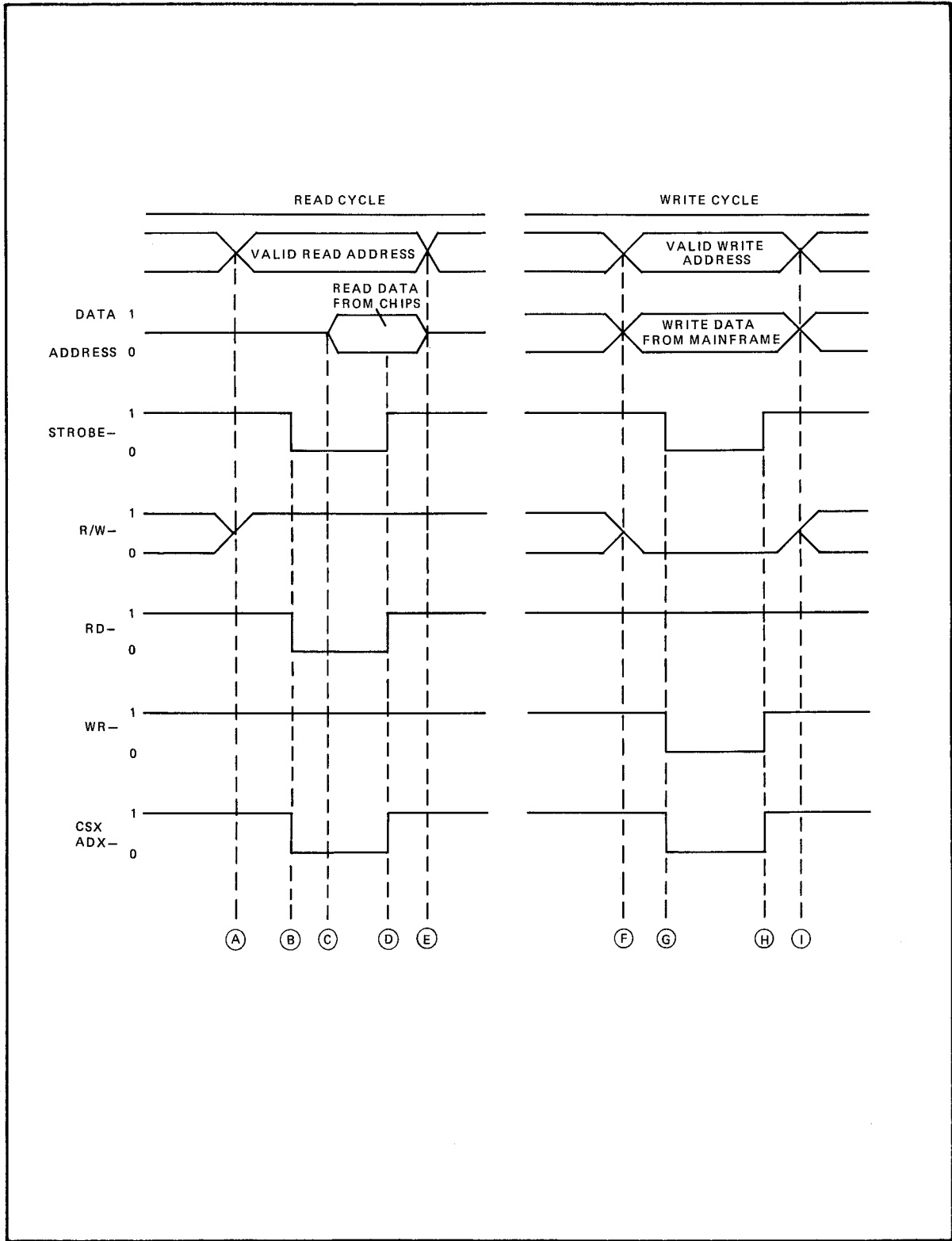

Figure 3-18. Bus Interface Timing Diagram

For example, to select "custom chip U100", the input at U7-13 (A07) from the address bus of the mainframe is at logic low, and U7-18 (A04), U7-17 (A05), and U7-14 (A06) are at logic high. At the occurrence of a strobe signal, U7 latches the logic levels on these pins. At the output signals of U7, LAT-A7 is logic high, and LAT-A4, LAT-A5, and LAT-A6 are logic low. U6 decodes the latched address lines and sets output line AD8- low. The logic low on AD8- is gated and sets up a logic low on CS0-, thereby enabling "custom chip U100". If this were to occur on I/O Module 3, address D0481 would be written.

A custom chip may be addressed individually, or all custom chips may be addressed simultaneously. Address bits A04 through A07 are used to determine custom chip selection. To address all chips, an address in the form DXXFX must be used. This address causes the ALLCHIP signal (U6-7) to go active, making all five chip selects active.

Custom Chip Functional Block

The custom chips each contain eight channels of data acquisition. Each channel performs 16-bit Cyclic Redundancy Checking (CRC), 23-bit (with overflow) transition counting, 3 bits of asynchronous level history recording, 3 bits of synchronous level history recording, and 1 bit of data comparison. The custom chips are used for I/O Module control, and they connect to the data bus via U8. Eleven internal registers control the custom chip. These registers are controlled by Address lines A01 through A03, and the R/W- line.

The pin-out of the custom chip is shown in Table 3-23.

Clock and Enable Mux Functional Block

The Clock and Enable Mux block is located on the I/O Module Main PCA and is shown in the I/O Module Functional Block Diagram, Figure 3-14. Two ICs make up this block: the 74HCT153 (U18) Dual 4:1 Select Multiplexer and the 74HCT04 (U4) Hex Inverter. This block selects one of three sources for the XCK- signal, and one of two sources for the XEN signal.

CLOCK AND ENABLE MUX OPERATION

Inputs

The Clock and Enable block receives inputs from the BUFENA (Buffer Enable) and the BUFCLK (Buffer Clock) signal lines. These signal lines originate from the XCLK (External Clock) and XENA (External Enable) lines. The PSYN (Pod Sync) signal obtained from the EXT-BUS (External Bus) is an alternative clock signal to the external clock and is used for data gathering by the custom chip(s). U18 inputs: POD SYNC, CALCLK1 (Calibration Clock 1), and CALCLK2 (Calibration Clock2) are all clock signals used by the Clock and Enable Mux Block. The POD SYNC signal, which enters the I/O Module as differential ECL, is converted by U9 into TTL levels. This signal enters the EXT-BUS to be used in conjunction with CALCLK1, CALCLK2, ENMUX, and CLKMUX.

Table 3-23. Custom Chip Pin Description

PIN	TYPE	FUNCTION
AO-A2	Input	Address lines
POR-	Input	Power-on reset
SRCK	Input	1 MHz Serial-to-Parallel conversion clock
PDRVO-PDRV7	Output	Pattern Drive PMOS gate drive
NDRVO-NDRV7	Output	Pattern Drive NMOS gate drive
VDD1	Input	Positive voltage supply
VDD2	Input	Positive voltage supply
GND1	Input	Logic common
GND2	Input	Logic common
XDO-XD7	Input/Output	Microprocessor data bus
EQ	Output	Equal (data comparison match) output
TC	Output	Test clock output
WR-	Input	Write enable
RD-	Input	Read enable
CS-	Input	Chip select
VPAT	Input	Negative supply for DRV outputs
TEN	Input	Test mode enable
XSTP	Input	External stop
GATE	Input	Frequency gate input
XSTR	Input	External start
XEN	Input	External enable
XCK	Input	External clock
PSYN	Input	Pod sync clock
VLO	Input	Low voltage threshold select for CDO-CD7
VHI	Input	Hi voltage threshold select for CDO-CD7
CDO-CD7	Input *	Channel inputs
TLI	Input	Test channel comparator input
TLO	Output	Test channel comparator output

* CDn inputs have an internal resistor network to control the voltage at which they will float (the "invalid" voltage). This voltage is approximately 1.6V, through an effective resistance of >50 kilohms.

The CALCLK2 signal enters the Main I/O PCA through the Connector Code Determination Block. CALCLK 1 is not used. Channels 1 through 39 are tied together and to CALCLK 2 when the Calibration Module is plugged in. CALCLK2 is an input to U18-13. The ENMUX and CLKMUX signals are generated by the Control Register (U14-15 and U14-16, respectively) and are control inputs to U18. U18 generates outputs XEN and XCK. Table 3-24 shows which signals appear on the outputs of the multiplexer for all four states of the control inputs.

Table 3-24. U18 Truth Table

Control In		Outputs	
CLKMUX	ENAMUX	XEN	XCK
0	0	BUFENA	BUFCLK
0	1	PSYN	BUFCLK
1	0	BUFENA	CALCLK 1
1	1	PSYN	CALCLK 2

Outputs

The Clock and Enable MUX block outputs XEN and XCK- signals to the EXT-BUS. These two control signals are sent to each custom chip. Three parallel inverters invert the XCK signal from U18-9, and are necessary to ensure a fast rise time into the relatively high capacitance XCK-line.

General Control Latch Functional Block

OVERVIEW

The General Control Latch block, located on the I/O Module Main PCA, is used to vary input thresholds, clear fault conditions, and control the Clock and Enable Multiplexer. Refer to Figure 3-14 for the block's functional relationship on the block diagram. The ICs in this block include: a 74LS273 (U14) 8-bit latch, an LM324 (U2) quad op-amp, two 2N3906 (Q1, Q2) PNP transistors, a 74LS08 (U3) quad 2-input AND gate, a 74LS30 (U15) 8-input NAND gate, and two 74LS112 (U11, U12) dual JK negative-edge-triggered flip-flops.

CONTROL REGISTER

Data lines from the A-D-BUS to U14 produce DCECLR- (Data Compare Equal Clear), GENCLR- (General Clear), FUSCLR- (Fuse Clear), ENMUX (Enable Multiplex), CLKMUX (Clock Multiplex), and THRSH (Threshold) signals. U14 is accessed by a write to DXXDX, where the ADD- and WR- latch data into U14. The Control Register (U14) is cleared by a PWRUP (Power Up) signal held low by C44 to ensure a proper reset.

The J2 and J3 connectors provide the input to the General Control Latch block for detection of Clip and Calibration Modules. J2-25 and J3-6 are the input pins to a detection circuit that provides the SWRDET (the right-hand or B Switch Detect) and SWLDET (the left-hand or A Switch Detect) signals to generate an interrupt. The mainframe reads the interrupt register to determine the reason for an interrupt.

3/Theory of Operation

DATA COMPARISON INPUTS

All 40 lines of the I/O Module are compared to a programmable 40-bit data register and qualified by a programmable 40-bit "don't care" register. This comparison is done inside the custom chip(s), eight lines per chip. The EQ outputs (pin 55 of the custom chip), are gated together, and, when they are all high (i.e., a comparison has been detected), an interrupt is generated.

FUSE DETECTION

The FUSEDET (Fuse Detect) is a part of the Multi-Detection area, General Control Latch Block. A 1A slow-blow ground fuse located on the I/O Module Main PCA is used to protect the ground line. The FUSEDET signal becomes an input to the interrupt register (U13-8), along with the other detection signals.

DATA COMPARISON and GENERAL INTERRUPTS

The General Control Latch block outputs detection and interrupt signals for any problems or special operations of the I/O Module. Also, an external DCE pin allows the user to examine the state of the I/O Module hardware.

The following two interrupts are produced by the General Control Latch block:

- o DCEINT- (Data Compare Equal Interrupt)
- o IOGENINT- (I/O General Interrupt)

The Data Compare Equal Interrupt

The DCEINT- is generated by the I/O Module when the programmed data compare register matches the input data. The DCEINT- signal originates from the EQ pin of each custom chip. The EQ signals are gated to form a DCE- signal. The DCE- signal triggers a J-K flip-flop to produce the DCEDET and DCEINT- signals.

The I/O General Interrupt

The IOGENINT- is an interrupt generated by the I/O Module when either pushbutton on a clip module is pressed. The interrupt status register on the I/O Module must be read to determine the cause. In the case of a button push, two J-K flip-flops output the SWLDET (A side) and SWRDET (B side) signals. These signals are gated to produce the IOGENINT- signal.

Data Compare Equal Output Pin

DCE output pin P1-6 can be used to trigger a logic analyzer or oscilloscope. Buffers and protection circuitry safeguard the DCE signal output.

OPERATION OF GENERAL CONTROL LATCH BLOCK

The General Control Latch Block is divided into three areas. These areas produce voltages for I/O Module operation and contain circuitry that generates detection for a blown fuse. The functional block contains the following areas:

- o Threshold Voltage Generation
- o Multi-Detection and Interrupt
- o Fuse Blown Detection

Threshold Voltage Generation

Threshold Voltage Generation produces the threshold voltages necessary for control of data input to the custom chips. Data Bit 7 of the command register (U14) determines the level of threshold, with a 1 selecting TTL, and a 0 for CMOS. See Figure 3-19 for the command register bit positions.

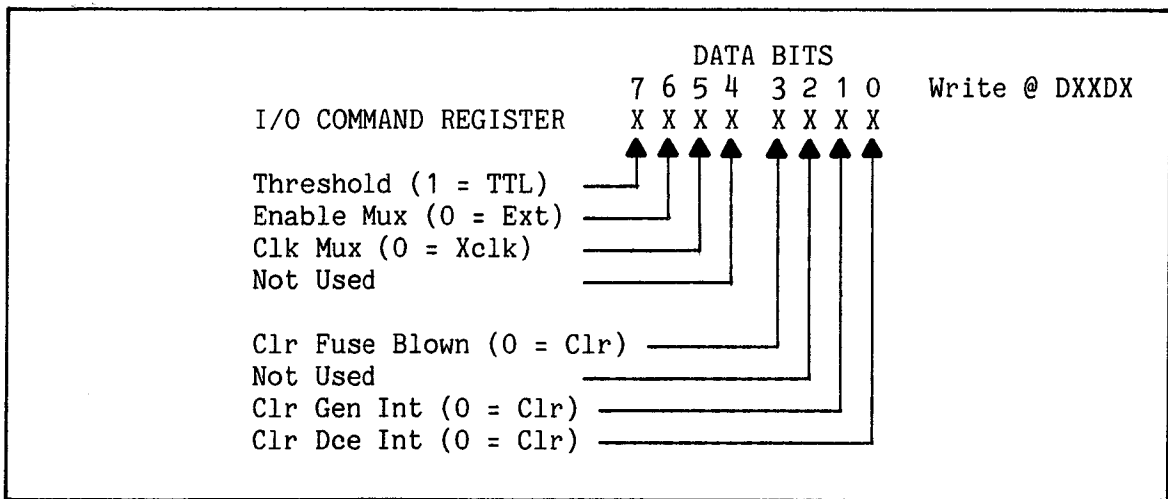

Figure 3-19. I/O Module Command Register

The threshold (THRSH) signal output of U14-19 passes through circuitry that produces a low voltage level (VLO), and a high voltage level (VHI). These voltage levels are used by the custom chips pins 39 and 45 to define the logic low, invalid, and logic high voltage ranges. A logic high out U14-19 designates a TTL logic level and a logic low for CMOS. The THRSH signal controls resistor dividers that are used to create the VHI and VHO signals. Two parts of op amp U2 and transistors Q1 and Q2 are used together to provide a regulated output with high current sinking capability. Typical current seen by these regulators can vary from 10 to 40 mA. Approximate VHI and VLO levels generated are listed in Table 3-25.

3/Theory of Operation

Table 3-25. VHI and VLO for TTL and CMOS Logic Levels

DESC	THRSH	VHI	VLO
TTL	1	-1.0V	-2.4V
CMOS	0	-0.25V	-2.2V

Within the custom chip, a voltage level-detection system uses data inputs, VHI, and VLO voltage levels to detect a high voltage input, a low voltage input, or a tristate situation. See Figure 3-20 for an illustration of detection circuitry within the custom chip.

NOTE

The actual input thresholds for the high and low comparators are computed from the formulas shown in Figure 3-20.

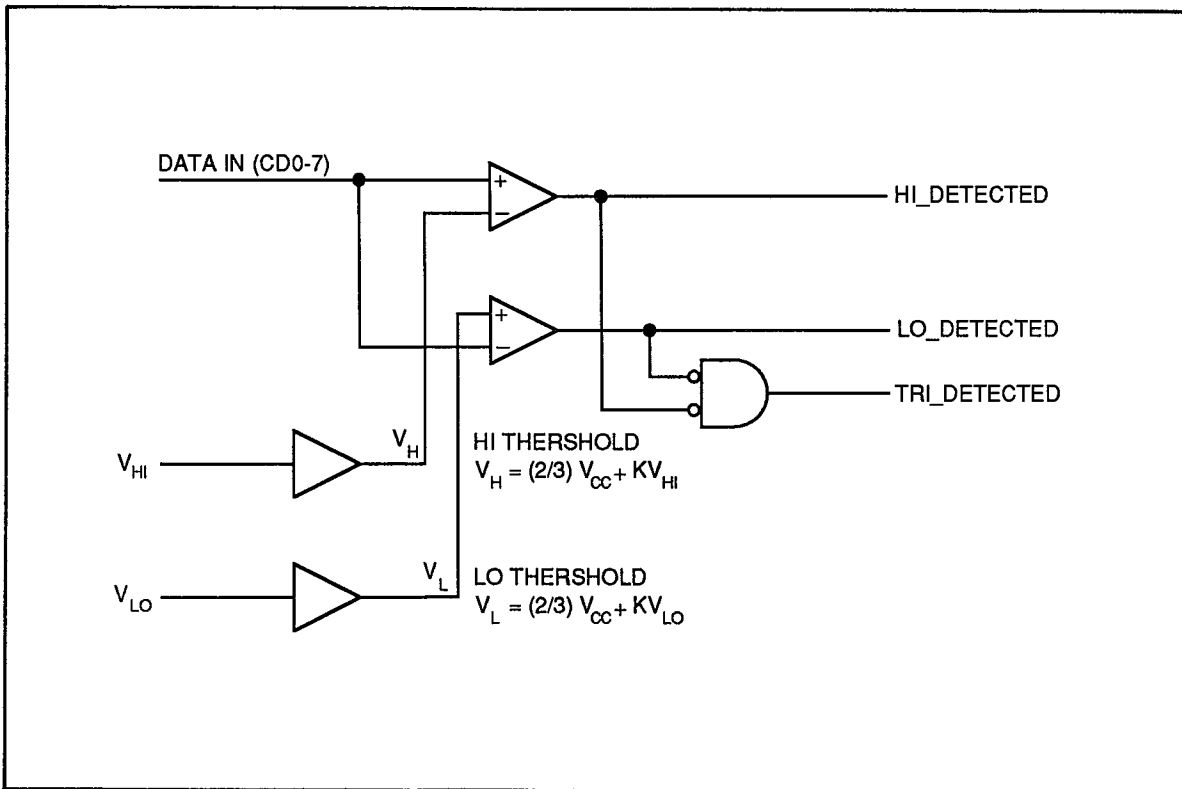

Figure 3-20. Custom Chip Voltage Level Detection

Multi-Detection and Interrupt

The I/O Module accepts different sizes of clip modules. A detection system within the I/O Module is necessary for the mainframe to know the size of the clip that has been installed on the I/O Module. Clip Modules are available in a half-size module and a full-size module. The half-size module plugs into one connector (either J2 or J3), and the full-size module plugs into both connectors (both J2 and J3). Together, clips plugged into both J2 and J3 generate an 8-bit code that can be decoded by the mainframe identify the plugged-in clips.

Fuse Blown Detection

Detection of blown fuses is performed by two LM324 (U2) op-amps and one part of U3 configured as a window detector. If the XGND signal exceeds a +/- 100 millivolt window, U3-6 will go low, forcing the FUSEDET line to go high. This means that when the Interrupt Register is read (READ @ DXXDX), a 1 in bit 3 indicates the fuse is blown. This blown fuse indication is cleared by writing to the I/O Command Register (WRITE @ DXXDX) with a data value having bit 3 = 0.

Connector Code Functional Block

The components associated with the Connector Code block are the 74HCT244 (U16) Octal buffer/line driver and part of J2 and J3 connectors. This block is located on the I/O Module Main PCA as indicated on function block diagram Figure 3-14.

The mainframe determines which Clip Module the user has installed by reading and decoding connector codes embedded in each Clip Module. To read the code, the mainframe performs a read @ DXXE1. This operation generates the ADE- signal, which in turn enables U16, placing the code on the data bus. Of the eight bits read, the lower four bits refer to the "A side", and the upper four bits refer to the "B side". Thus, differentiation is possible for 16 different conditions on each side of the module. Clips that use up an entire module use an 8-bit code. The most significant nibble of these codes is 1110. For a list of the codes, see Table 3-26.

3/Theory of Operation

Table 3-26. Dip-Clip and Calibration Module Configuration Codes

4 BIT CODE	MEANING
0000	14-Pin Clip
0001	16-Pin Clip
0010	18-Pin Clip
0011	20-Pin Clip
0100	24-Pin Clip
0101	(reserved)
0110	Used as most significant byte of calibration header
0111	(reserved)
1000	(reserved)
1001	(reserved)
1010	(reserved)
1100	(reserved)
1101	20-Pin Flying Lead Set
1110	Full width connector, use other 4 bits for ID
1111	No Clip Installed

8 BIT CODE	MEANING
7654 3210	
1110 0000	28-Pin Clip
1110 0001	40-Pin Clip
1110 0010	Calibration Header
0110 0010	Calibration Header
1110 0011	(reserved)
1110 0100	(reserved)
1110 0101	(reserved)
1110 0110	(reserved)
1110 0111	(reserved)
1110 1000	(reserved)
1110 1001	(reserved)
1110 1010	(reserved)
1110 1011	(reserved)
1110 1100	(reserved)
1110 1101	(reserved)
1110 1111	(reserved)
1111 1111	No Clips Installed

CONNECTOR CODE EXAMPLES

If the connector codes are to be determined on I/O Module 3, a Read @ D04E1 would be performed. Table 3-27 presents some examples of codes and their interpretation.

Table 3-27. Connector Codes

DATA READ	MEANING
F3	No clip on B side, 20 pin clip on A side
4F	24 pin clip on B side, no clip on A side
E1	40 pin clip installed
14	16 pin clip on B side, 24 pin clip on A side
FF	no clips installed

Input Protection/FET Output Block

OVERVIEW

The Input Protection/FET Output Block combines the functions of input channel protection for each custom chip and output for the I/O Module. Input protection clamps overvoltage, undervoltage, and static conditions before they reach the custom chip.

The output circuitry uses complementary N and P channel DMOS FETs. These FETs can be commanded to drive the I/O line high or low or leave it undriven (off). The custom chip drives these FETs through a 74HC244 buffer. Figure 3-21 shows a simplified circuit of a single channel. All 40 channels are functionally identical to each other.

This output circuit uses power supplies +VDRV and -VDRV. These voltages are generated, regulated, and current limited on the Probe I/O and I/O Connector PCAs. The nominal voltages for these supplies are 5 volts and -0.85 volt, respectively.

INPUT PROTECTION SECTION OPERATION

Data from the I/O lines travels through its respective connector into the protection circuit. Diodes connected to +5 volts and ground protect the custom chip from undervoltage and overvoltage.

FET OUTPUT SECTION OPERATION

The output block can assume three states: high, low, and off. The output block, in conjunction with the input block, allows for measurement of signals at the inputs. The truth table shown in Table 3-28 lists the logic levels of NDRV and PDRV.

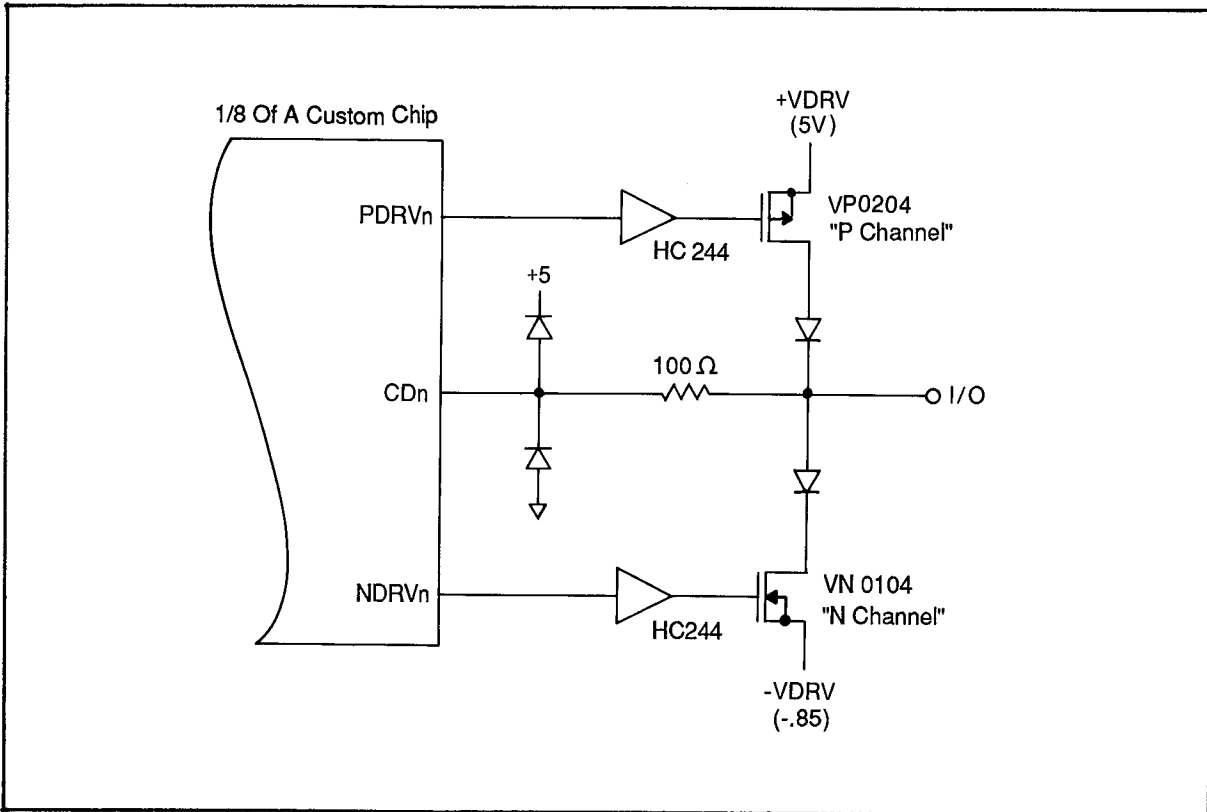

Figure 3-21. Chip Channel Input/Pattern Drive Output Simplified Schematic

Table 3-28. Logic Levels of NDRV and PDRV

OUTPUT	NDRV	PDRV
HI	0	0
LO	1	1
OFF	0	1
(illegal)	1	0

I/O Module Top PCA Functional Block

The top PCA of the I/O Module is a four-layer board consisting of connectors J2 and J3, banana plugs P1-P4, headers J1 and J4, and four 4700 uF capacitors. The top board connectors (J2, J3) provide the input for the 40 I/O lines from the Clip or Calibration Module. The four capacitors together form an effective 4700-uF bipolar capacitor. This is placed across the ground fuse to lower the fuse impedance. P1-P4 represent reference plug-in points between the plug-in module and the I/O Module for external ground and signal ground. The top I/O Module PCA allows for plug-in of a half or full Clip Module or a Calibration Module. These modules plug into J2 and/or J3 of the top PCA and transfer I/O lines to J2 and J3 of the I/O Module Main PCA. P1 and P3 are the signal ground connection points between the I/O Module and the Clip Module. P2 and P4 are the external ground connection points. These connection points improve grounding by providing multiple paths between the clip modules and the I/O Module.

DIP CLIP AND CALIBRATION MODULE FUNCTIONAL BLOCK

The Clip Module is a 9100A/9105A system accessory that offers the user a selection of configurations to test UUT I/O lines. There are two different sizes, a half width and a full width. The number of pins each size can handle is explained in the following paragraphs. The Calibration Module is another unit that the user installs onto the top of the I/O Module for calibration of clock signals.

Overview of the Clip and Calibration Modules

The Half-Width Clip Module is used for connecting the I/O Module to an IC. Five modules are available, in 14-, 16-, 18-, 20-, and 24-pin configurations. If one of these IC clip modules cannot be used, a 20-pin flying lead set is available.

The Full-Width Clip Module connects the I/O Module to 28- and 40-pin IC configurations. The Full Width Module contains two connectors to provide access for up to 40 I/O lines and a ribbon cable attached to either a 28- or a 40-pin IC clip.

The Calibration Module helps perform I/O Module calibration by assuring that simultaneous level transitions occur at both the clock and data inputs of the I/O Module. The clock and data inputs are recorded simultaneously by the latches in the I/O Module. The Calibration Module attaches to the two I/O Module connectors (J2, J3).

3/Theory of Operation

Clip and Calibration Module Operation

HALF WIDTH CLIP MODULE

The user plugs the Clip Module into the top of the I/O Module, then attaches the clip connected to a ribbon cable to the UUT. The Half Width Module can be connected to J2 (A side) or J3 (B side) of the I/O Module.

NOTE

Check the schematic for the I/O signals lines used in each case.

An SPST four-position dip switch contained in the Half-Width Module determines the code for the module. This code tells the mainframe the type of pin configuration used during the current I/O test. The connector code is factory set, and should not be changed. For a list of connector codes, see Table 3-27. A black ID button located on the front of the module housing can be used to signal the mainframe.

FULL-WIDTH CLIP MODULE

The Full-Width Module connects to IC chips under test (28- and 40-pin configurations). The Full-Width Module uses the same procedures and tests as the Half-Width Module. The Full-Width Module uses both I/O Module connectors for the additional I/O signal lines.

To identify the connection code of the Full-Width Module, the Module contains an SPST eight-position DIP switch. The Full-Width Module requires an 8-bit connection code so that the mainframe can determine the size of the clip the user has plugged into the I/O Module. A black ID button located on the front of the Full-Width Module is used to signal the mainframe.

CALIBRATION MODULE

The Calibration Module is used in calibrating both the delay between the data input and the external clock output and the delay between the data input and the pod synchronous clock. The Calibration Module ties channels 1 through 39 and CALCLK2 together. Channel 40 is connected to a "Flying Lead" and is used for calibration to the pod. With the Clock Multiplexer (U18) signal properly programmed, CALCLK2 appears on the XCK lines and clocks all of the custom chips. The Calibration Module connection code is hard-wired as Hex E2. The Calibration Module has an ID button located externally for detection by the mainframe.



static awareness



A Message From
John Fluke Mfg. Co., Inc.

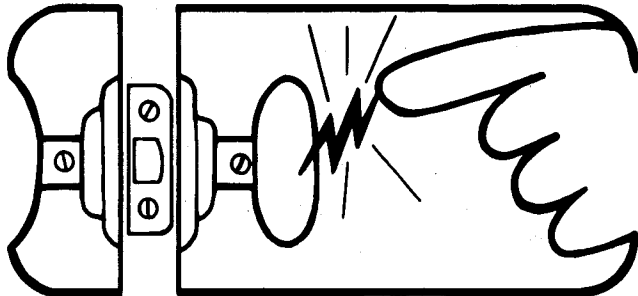

Some semiconductors and custom IC's can be damaged by electrostatic discharge during handling. This notice explains how you can minimize the chances of destroying such devices by:

1. Knowing that there is a problem.
2. Learning the guidelines for handling them.
3. Using the procedures, and packaging and bench techniques that are recommended.

The Static Sensitive (S.S.) devices are identified in the Fluke technical manual parts list with the symbol "⚡"

The following practices should be followed to minimize damage to S.S. devices:

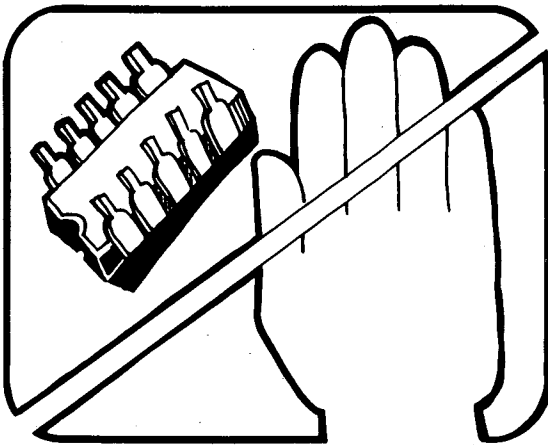

1. MINIMIZE HANDLING

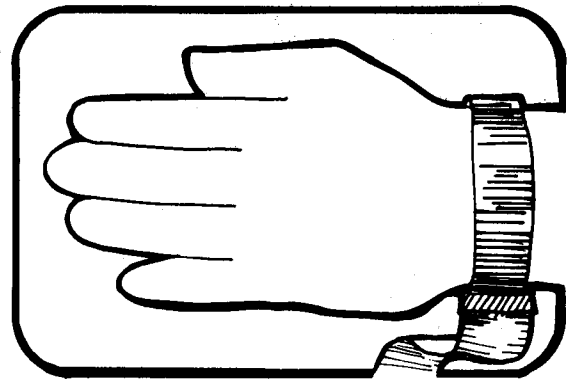

3. DISCHARGE PERSONAL STATIC BEFORE HANDLING DEVICES. USE A HIGH RESISTANCE GROUNDING WRIST STRAP.

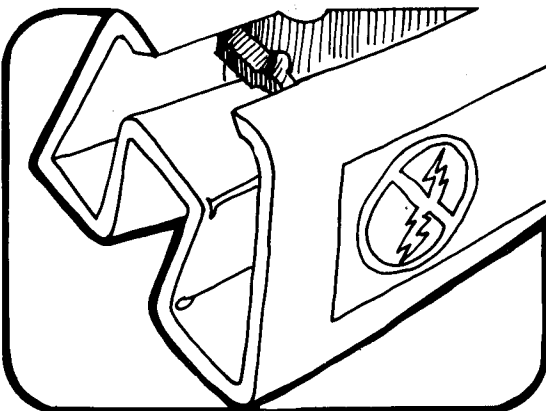

2. KEEP PARTS IN ORIGINAL CONTAINERS UNTIL READY FOR USE.

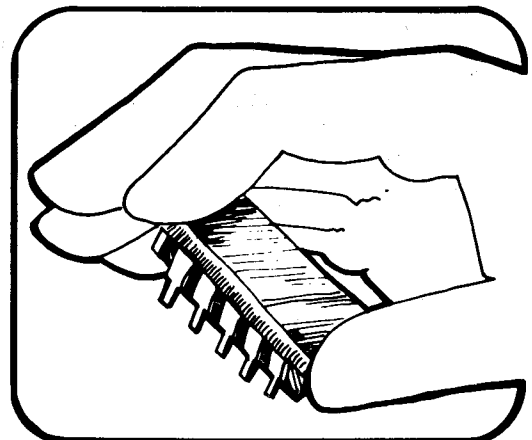

4. HANDLE S.S. DEVICES BY THE BODY

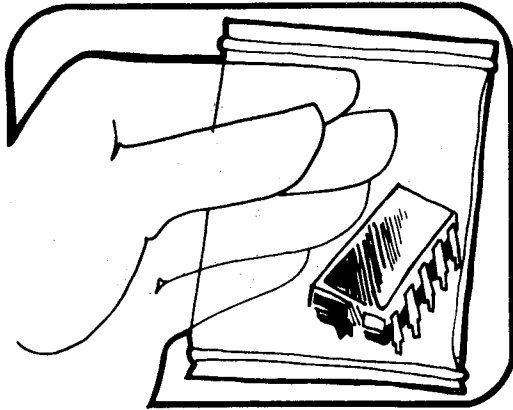

5. USE STATIC SHIELDING CONTAINERS FOR HANDLING AND TRANSPORT

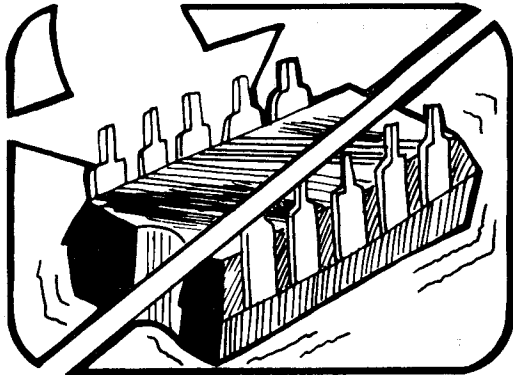

6. DO NOT SLIDE S.S. DEVICES OVER ANY SURFACE

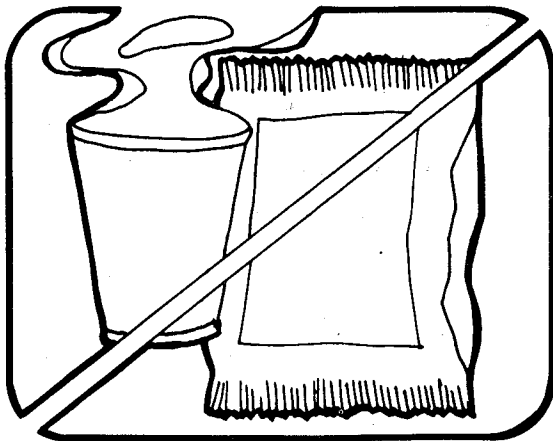

7. AVOID PLASTIC, VINYL AND STYROFOAM® IN WORK AREA

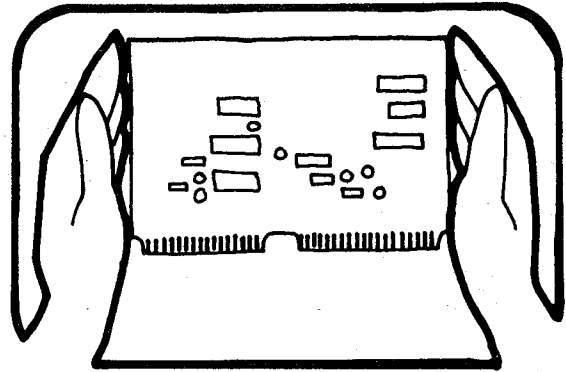

8. WHEN REMOVING PLUG-IN ASSEMBLIES, HANDLE ONLY BY NON-CONDUCTIVE EDGES AND NEVER TOUCH OPEN EDGE CONNECTOR EXCEPT AT STATIC-FREE WORK STATION. PLACING SHORTING STRIPS ON EDGE CONNECTOR HELPS TO PROTECT INSTALLED SS DEVICES.

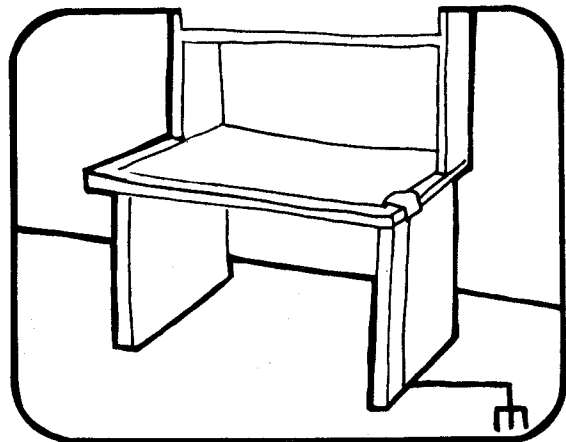

9. HANDLE S.S. DEVICES ONLY AT A STATIC-FREE WORK STATION

10. ONLY ANTI-STATIC TYPE SOLDER-SUCKERS SHOULD BE USED.

11. ONLY GROUNDED TIP SOLDERING IRONS SHOULD BE USED.

A complete line of static shielding bags and accessories is available from Fluke Parts Department, Telephone 800-526-4731 or write to:

JOHN FLUKE MFG. CO., INC.
PARTS DEPT. M/S 86
9028 EVERGREEN WAY
EVERETT, WA 98204

PORTIONS REPRINTED
WITH PERMISSION FROM TEKTRONIX, INC.
AND GENERAL DYNAMICS, POMONA DIV.

CONTENTS

Introduction	4-3
Selecting Line Voltage	4-3
Selecting Mainframe Line Voltage	4-3
Selecting Monitor Line Voltage	4-6
Changing Fuses	4-7
Changing the Mainframe Fuse	4-7
Changing the Probe Fuse	4-7
Changing the Clock Module Fuse	4-7
Changing the I/O Module Fuse	4-8
Cleaning	4-8
General	4-8
Fan Filter	4-9
Floppy Disk Drive	4-9
Mainframe Access, Removal, and Installation Techniques	4-9
System Connections	4-9
Mainframe Access	4-9
Operator Keypad/Display	4-12
Removing the Assembly	4-12
Separating the Subassembly	4-12
Disassembling the Keypad	4-12
Disassembling the Disk System	4-14
Removing the Hard Disk Controller	4-14
Removing the Disk Drive Assemblies	4-14
Installing the Disk Drive Assemblies	4-14
Removing the Power Supply	4-14
Removing the MFI and Video Controller PCAs	4-16
Removing the I/O Connector Interface PCA	4-16
Removing the Probe I/O Module Interface PCA	4-16
Removing the Main PCA	4-16
Programmer Keyboard Access Procedure	4-17
Screen Overlay	4-18
Recommended Use	4-18
Removing the Overlay	4-18
Installing the Overlay	4-18
Monitor Access, Removal, Installation Techniques	4-19
Removing the Monitor Cover	4-19
Accessing the Monitor Chassis	4-19
Removing the Front Bezel	4-19
Monitor Power Supply	4-21
Removing the Monitor Power Supply	4-21
Installing the Monitor Power Supply	4-22

Monitor Display PCA	4-24
Removing the Display PCA	4-24
Installing the Display PCA	4-26
CRT and Yoke	4-28
Removing the CRT and Yoke	4-28
Installing the CRT and Yoke	4-30
Monitor Adjustment	4-32
Deciding on CRT Replacement	4-37
Self Test Routines	4-38
Power-Up Self Test	4-38
Probe Self Test	4-38
Pod Self Test	4-41
I/O Module Self Test	4-42
Display Self Test	4-42
Calibration	4-45
Probe Offset Correction	4-46
Probe Compensation	4-46
Software Calibration	4-48
Probe to External (Clock Module)	4-48
Probe to Pod	4-49
I/O Module to External	4-50
I/O Module to Pod	4-50
Saving and Restoring Calibration Data	4-51
Invalid Calibration Data	4-52
Saving Calibration Data	4-52
Restoring Calibration Data	4-53
Troubleshooting	4-54
Repair	4-54
General Repair	4-54
Static Awareness	4-54
Components	4-54
Surface Mount Repair	4-54
Surface Mount Technology	4-54
Repair Techniques	4-60
Tools and Supplies	4-64
Repair Information	4-66
General	4-66
Main PCA	4-66
Display and Keypad	4-66
Probe I/O	4-67
I/O Connector	4-67
Clock Module	4-67
Single-Point Probe	4-67
RAM Modules	4-68
Power Supply	4-68
Floppy Disk Drive	4-69
Hard Disk and Controller	4-69
Multi-Function Interface	4-70
Video Controller	4-70
Monochrome Monitor	4-71
I/O Module	4-71
Clip and Flying Lead Modules	4-71

WARNING

SERVICING DESCRIBED IN THIS SECTION IS TO BE PERFORMED BY QUALIFIED SERVICE PERSONNEL ONLY. TO AVOID ELECTRICAL SHOCK, DO NOT PERFORM ANY SERVICING UNLESS YOU ARE QUALIFIED TO DO SO.

INTRODUCTION

This section describes maintenance procedures for the 9100A/9105A. Some of these procedures do not require access to the instrument and can be performed by the operator. Troubleshooting procedures, which are covered in detail in the 9100A/9105A Service Kit, may require reference to the disassembly and reassembly instructions found in this section.

Refer to Table 4-1 for a list of tools and test equipment required during 9100A/9105A maintenance.

SELECTING LINE VOLTAGE

Selecting Mainframe Line Voltage

The mainframe line voltage selection switch is located on the 9100A/9105A rear panel. The switch setting (110V or 220V) must correspond to the local line voltage as follows:

Setting	Voltage/Frequency Range	Required Fuse (F1)
110V	90 to 132V ac, 47 to 440 Hz	2A SLOW BLOW
220V	180 to 264V ac, 47 to 63 Hz	1A SLOW BLOW

A correct setting can be verified visually at any time. Otherwise, to change the setting, use the following procedure:

1. Ensure that the 9100A/9105A is turned off and its line power cord is disconnected.
2. Rotate the rear panel switch to the desired setting (110V or 220V).
3. If necessary, replace the power fuse as described later in this section. See Table 4-2 for the fuse part number.
4. Connect the power cord to the correct line voltage, and turn the 9100A/9105A on.

Table 4-1. Required Tools and Test Equipment

EQUIPMENT REQUIRED FOR GENERAL SERVICING		
EQUIPMENT	RECOMMENDED MODEL	FUNCTION/COMMENTS
Digital Multimeter	Fluke Model 77	
Oscilloscope	Philips Model PM3065 (or equivalent)	
Adjustment Tool	P/N 800540	
Flat Blade Screwdriver		1/8-inch (3 mm) blade
Flat Blade Screwdriver		1/4-inch (6 mm) blade
Phillips Screwdriver		#2, blade 4 inches (10 cm) or longer
Hex Driver		3/16-inch (5 mm)
Hex Driver		5/16-inch (8 mm)
Wrench		3/16-inch (5 mm) or adjustable
REQUIRED EQUIPMENT FOR COMPONENT LEVEL REPAIR		
EQUIPMENT	RECOMMENDED MODEL	FUNCTION/COMMENTS
9100A Service Kit	P/N 818948	
Digital Test Station, with I/O Module	Fluke Model 9105A (or 9100A) with 9100A-003 option	Runs programs supplied with Service Kit
68000 Interface Pod	Fluke Model 9000A-68000	Used with Service Kit
Surface Mount Repair tools		See Table 4-6

Table 4-1. Required Tools and Test Equipment (cont.)

REQUIRED EQUIPMENT FOR MONOCHROME MONITOR MAINTENANCE		
EQUIPMENT	RECOMMENDED MODEL	FUNCTION/COMMENTS
Hex Adjustment Tool	P/N 572321	Horizontal Size/Linearity
Alignment Template	P/N 777144	Use with Monitor Pattern Program
Long-Nose Pliers		
Flat-Blade Screwdriver		1/4-inch (6 mm) blade, plastic handle with blade at least 5 inches (12.5 cm) long.
Phillips Screwdriver		#2, plastic handle with blade at least 3 inches (7.5 cm) long.
Phillips Screwdriver		#2, non-magnetic tip blade, plastic handle, with blade at least 12 inches (30 cm) long, for crt replacement.
Torque Hex Driver		3/16-inch (5 mm).
Soft Pad (foam or quilted)		Approximately 8 x 10 inches (20 x 25 cm).
1 megohm, 1W Resistor	P/N 109793	To discharge crt anode.
Clip Leads (2)		For connecting resistor to chassis and screwdriver shaft.
Safety Gloves		Mid-forearm length, soft leather.
Full Face Shield (preferred) or Safety Goggles		
Lab Smock with Zipper		Plastic zipper. Metal parts should not come in contact with crt.

Selecting Monitor Line Voltage

The line voltage selection switch for the Fluke Monochrome Monitor is located on the monitor rear panel. The mainframe voltage setting (110V or 220V) must be repeated with the Monitor. No fuse changes are required with monitor line voltage changes.

Setting	Voltage/Frequency Range
110V	90 to 132V ac, 47 to 440 Hz
220V	180 to 264V ac, 47 to 440 Hz

To change the setting, use the following procedure:

1. Set the rear panel power switch to off ("0").
2. Rotate the rear panel switch to the desired setting (110V or 220V).
3. Connect the power cord to the correct line voltage, and set the power switch to on ("1").

CHANGING FUSES

Changing the Mainframe Fuse

The mainframe fuse (labeled F1) is accessible from the rear panel. Prior to changing the fuse, set power to off and remove the line power cord. Then, press in and turn the fuse holder cap counterclockwise. Fuse sizes are:

110V	2A SLOW BLOW
220V	1A SLOW BLOW

See Table 4-2 for fuse part numbers.

Changing the Probe Fuse

An operator display message ("probe fuse blown") indicates that the probe fuse has opened. This problem can occur when the probe common lead is incorrectly connected to the UUT.

Prior to replacing the fuse, determine the incorrect common lead connection. Then disconnect probe leads and replace the fuse as follows:

1. Locate the fuse holder, labeled PROBE FUSE, on the mainframe right side.
2. Press the fuse holder cap in, then rotate it counterclockwise.
3. Pull the cap and fuse straight out. Separate the fuse cap and fuse.
4. Use a 0.25A, 250V fast-blow fuse. See Table 4-2 for the fuse part number.

Changing the Clock Module Fuse

An operator display message ("clock module fuse blown") indicates that the Clock Module fuse has opened. This problem can occur when the Clock Module COMMON lead is incorrectly connected to the UUT.

Prior to replacing the fuse, determine the incorrect COMMON lead connection. Then disconnect all Clock Module leads and replace the fuse as follows:

1. Locate the fuse holder on the Clock Module.
2. Press the fuse holder cap in, then rotate it counterclockwise.
3. Pull the cap and fuse straight out. Separate the cap and fuse.
4. Use a 0.25A, 250V fast-blow fuse. See Table 4-2 for the fuse part number.

Changing the I/O Module Fuse

An operator display message ("I/O module fuse blown") indicates that the I/O Module fuse has opened. This problem can occur when the I/O Module COMMON lead is incorrectly connected to the UUT.

Prior to replacing the fuse, determine the incorrect COMMON lead connection. Then disconnect all I/O Module leads and replace the fuse as follows:

1. Locate the fuse holder on the back of the I/O Module, near the cable.
2. Press the fuse holder cap in, then rotate it counterclockwise.
3. Pull the cap and fuse straight out. Separate the cap and fuse.
4. Use a 1A, 250V slow blow fuse. See Table 4-2 for the fuse part number.

Each 9100A or 9105A uses one of two different types of fuses. Instruments configured at the factory for 110V line voltage use 1/4 x 1-1/4 inch fuses with grey fuse holder caps. Instruments configured at the factory for 220V use 5 mm x 20 mm fuses with black fuse holder caps. First, check the color of the fuse cap (grey caps hold U.S. fuses; black caps hold metric fuses). Then select the fuse part number as shown in Table 4-2.

Table 4-2. Fuse Part Numbers

FUSE	US P/N	METRIC P/N
2A SLOW BLOW:	109181	na
1A SLOW BLOW:	109272	808055
0.25A FAST BLOW:	109314	543504

The fuse holder cap is part number 460238 for U.S (grey) usage and 461020 for metric (black) usage.

CLEANING

General

CAUTION

Do not use aromatic hydrocarbons (such as gasoline or other fuels) or chlorinated solvents for cleaning. They may damage plastic materials used in the instrument.

Avoid using excessive amounts of liquid, particularly around the keypad, keyboard, or disk drives.

Both the operator's display and the monitor screen should be cleaned with a soft cloth that has been lightly dampened with a cleaner. Commercially-available lens or crt cleaners or nonabrasive household cleaners are appropriate for this purpose.

Clean the instrument exterior and accessory cables with either a mild solution of detergent and water or a nonabrasive household cleaner.

The operator's keypad and keyboard should be cleaned gently with a cloth or towel that has been lightly dampened with either a nonabrasive household cleaner or a mild solution of detergent and water.

Fan Filter

The fan filter should be cleaned at least once every 90 days, or more often if necessary, to ensure the free flow of cooling air. The filter is positioned behind the louvered filter cover found on the mainframe right side.

To remove the filter, first pull on the cover at both sides of the upper disk drive. Once the latching pins have snapped out of the chassis, lift up on the cover until its bottom is free. Remove and clean the foam filter. Use warm water and detergent.

Floppy Disk Drive

Each floppy disk drive should be cleaned at least once a year. Cleaning involves running a commercially-available cleaning disk in the drive for five seconds.

MAINFRAME ACCESS, REMOVAL, AND INSTALLATION TECHNIQUES

System Connections

System connections are fully explained in the Getting Started guide. Here, in the Service Manual, Figures 4-1 and 4-2 also illustrate system component interconnections. If additional information about reconnecting the system is needed, refer to the Getting Started Guide.

Mainframe Access

WARNING

TO REDUCE THE RISK OF ELECTRIC SHOCK ALWAYS TURN OFF THE 9100A/9105A AND DISCONNECT THE POWER CORD FROM THE PANEL ON THE REAR OF THE CHASSIS BEFORE ACCESSING THE MAINFRAME.

1. With the instrument positioned bottom side up, remove the five screws securing the top. There are two screws on each of the side lips and one screw located at the bottom front.
2. Holding case top and bottom together, rotate the entire instrument to the top up position.
3. Working from the front of the instrument, remove the top cover by gently lifting at midpoint on both sides.

NOTE

Once the cover is free of the mainframe, notice the various cables attached between it and the mainframe. Protect these cables by proceeding cautiously with the following steps.

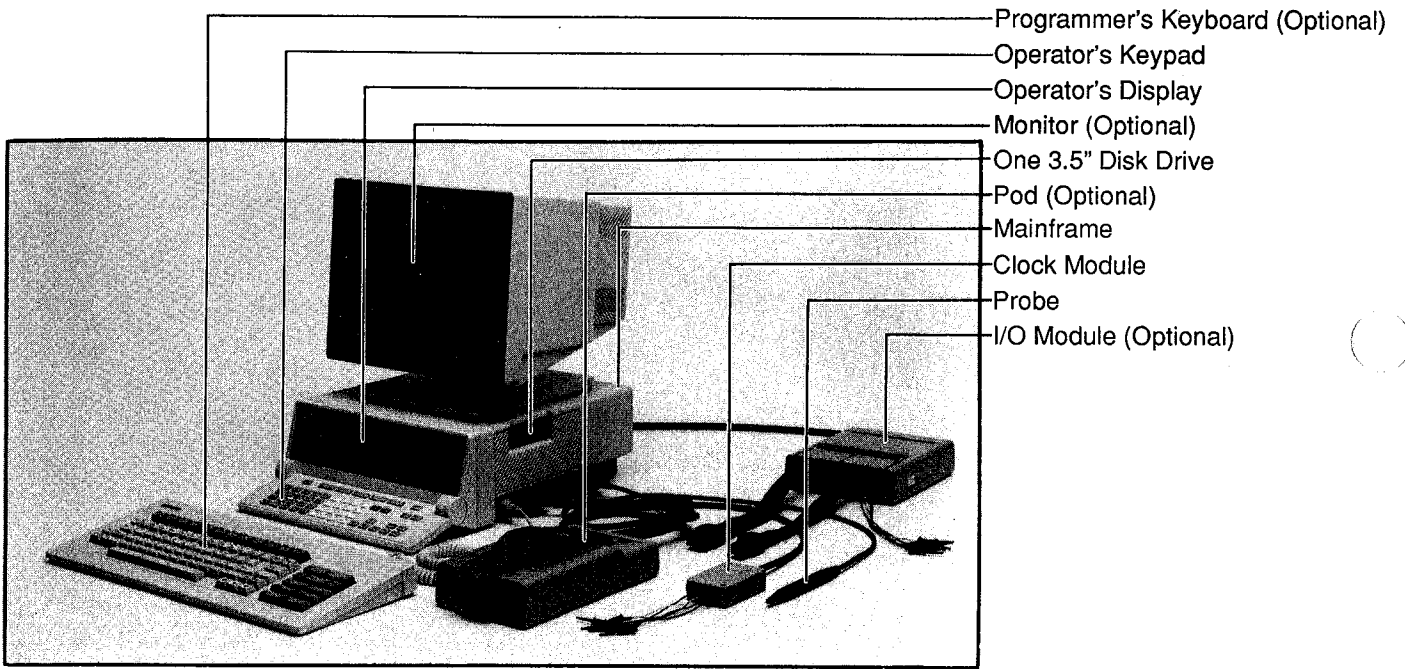

Figure 4-1. 9100A System

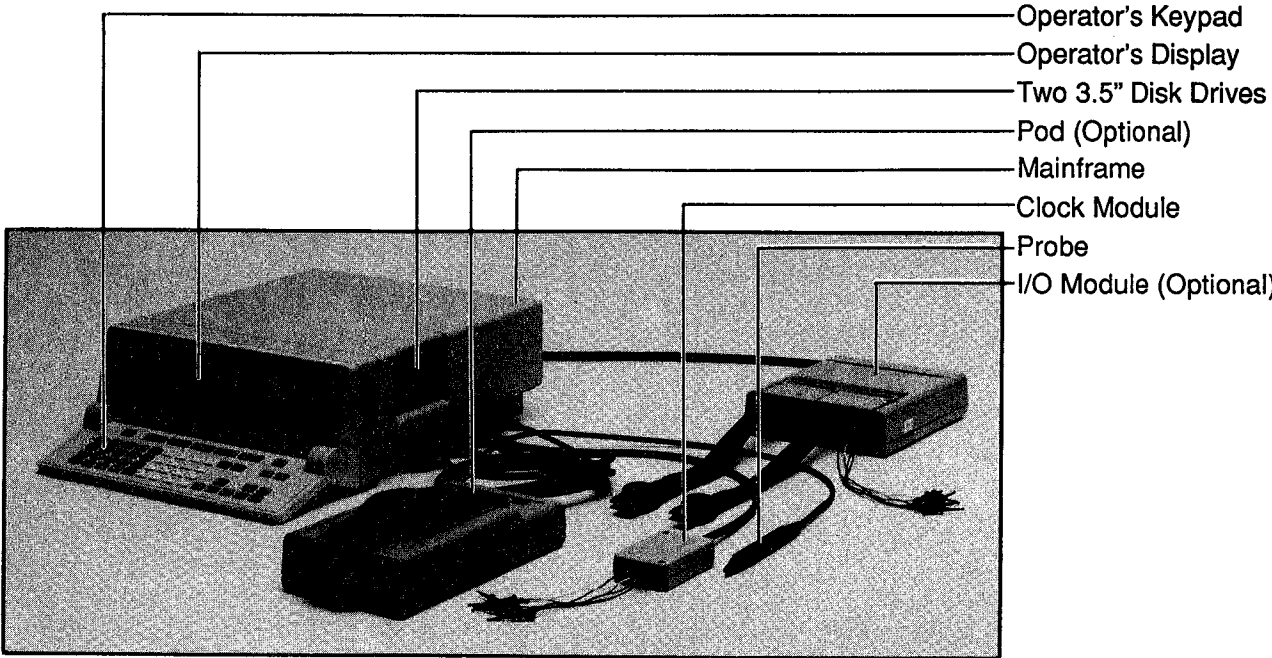

Figure 4-2. 9105A System

4/Maintenance

4. Rotate the cover 90 degrees clockwise.
5. Tilt the top cover 90 degrees to the left, placing it on a flat surface next to the mainframe. In this position, the floppy disk drive is on edge, facing forward.

CAUTION

The floppy disk drive must be positioned properly to function reliably. Do not position the removed cover so that the floppy disk drive is on top, facing up. Also, the hard disk drive (9100A only) may fail if operated in an incorrect position.

Any instrument assembly or subassembly can now be removed. Note that removal of some assemblies requires prior removal of other assemblies.

Operator Keypad/Display

REMOVING THE ASSEMBLY

The Keypad/Display is attached to the mainframe electrically with one ribbon cable and is physically attached with two screws. First, disconnect the cable at either end (J11 on the Main PCA, or J1 on the Display Interface PCA) by grasping the connector and pulling with a gentle end-to-end rocking action. Then remove the two screws (one at each pivot point), and pull the Keypad/Display free of the mainframe.

SEPARATING THE SUBASSEMBLY

The Keypad and Display can be separated by first disconnecting the ribbon cable connector at J2 (Display Interface PCA). Grasp the connector at both ends and pull with a gentle end-to-end rocking action. Then remove the two securing screws, one at each corner of the pca case. Finally, while guiding the ribbon cable and connector through the respective pca opening, pull the Keypad and Display subassemblies apart.

NOTE

On the Keypad, the two round rotator caps are no longer secured in place when the subassemblies are detached. These caps should be retained separately to avoid inadvertent loss.

When reconnecting the Keypad and Display subassemblies, route the ribbon cable/connector back through the pca opening, but avoid actual connection to the pca until the two securing screws are tightened. This sequence avoids undue stress on the cable and connector.

DISASSEMBLING THE KEYPAD

Although Keypad disassembly is seldom necessary, it can be accomplished quite easily. Before beginning disassembly, awareness of the two precautions is important.

- o Once the keypad halves are separated, the keys are no longer secured in place. Avoid key loss by separating the keypad and case only when the keypad is upside down (keys facing down).
- o Each rotator cap conceals a spring and plastic securing flange. Particularly note the flange orientation; a small "R" faces right, and a small "L" faces left. Each flange must be reinstalled in the same manner. Also, the springs are not secured in place once the keypad halves are separated and must be separately retained. When separating the keypad halves, note the location of the alignment holes used by the springs.

Use the following steps to separate the two keypad case halves:

1. Remove the screw found along the rear of the keypad.
2. Turn the keypad so that the keys face down, then pull off the securing flange revealed under each rotator cap. Note the orientation of the torsion springs (one at each end).
3. Now pry the two case halves apart, and remove the torsion springs. Leave the key half facing down until otherwise called for during reassembly.

Use the following procedure to reconnect the keypad case halves.

1. With the key half still facing down, install the torsion springs in their respective alignment holes.
2. Now, while holding each spring in place, lower the bottom half onto the key half.
3. Once the springs are properly aligned, install the two securing flanges in the same orientation as noted earlier.
4. Carefully rotate the two halves so that the keys face up. Then press and secure each of the three securing tabs along the front.
5. Install the securing screw.

Disassembling the Disk System

REMOVING THE HARD DISK CONTROLLER

On the front of the Hard Disk Controller card, apply pressure to the card edge, then carefully rock the 50-pin ribbon cable connector loose from J1.

On the rear of the card, remove the 20-pin ribbon cable connector from J2. Then disconnect P1 and J4, both found at the rear card edge.

Now physically disconnect the PCA by removing the screws and gently disengaging its standoff/retainers.

4/Maintenance

REMOVING THE DISK DRIVE ASSEMBLY

Refer to Figure 4-3. In sequence, remove the two card-edge connectors on the hard disk (9100A only), the 34-pin ribbon cable connector at J14 (Main PCA), and the seven screws securing the disk drive assembly. Grasp the assembly securely before removing the final screw.

The disk drives can now be removed from the disk drive assembly as described below.

- o Floppy Disk Drive: Remove the two screws from each side. Lift or slide the drive out. Then remove the power connector.
- o Hard Disk Drive: Remove the two screws from each side. Gently slide the drive out. Then disconnect the power connector.

CAUTION

The Hard Disk Drive is extremely fragile. Do not jar this assembly at any time during installation or removal.

INSTALLING THE DISK DRIVE ASSEMBLY

Generally, reassembling and installing the Disk Drive Assembly involves reversing the steps used above during removal. Make sure the 34-conductor ribbon cable and the 4-conductor discrete cable are not pinched between the disk drive assembly and the top cover.

Removing the Power Supply

The Power Supply Assembly uses electrical connections to the Main PCA, the rear panel fuse and power switch, and the disk drive assemblies (as applicable). Disconnect the related cables at the Main PCA and at the in-line connector leading to the rear panel fuse/power switch.

To remove the connections to the disk drives, remove the Disk Drive Assembly, and unplug the power connectors to the floppy disk drive(s), hard disk (9100A only), and hard disk controller (9100A). Disk drive disconnection can also be accomplished by removing the power supply wiring harness from the terminal blocks on the Power Supply Assembly.

Remove the five securing screws, and lift the Power Supply PCA free. Note that four shoulder screws (with nylon washers) are used in the corners. Make sure these items are used during reassembly.

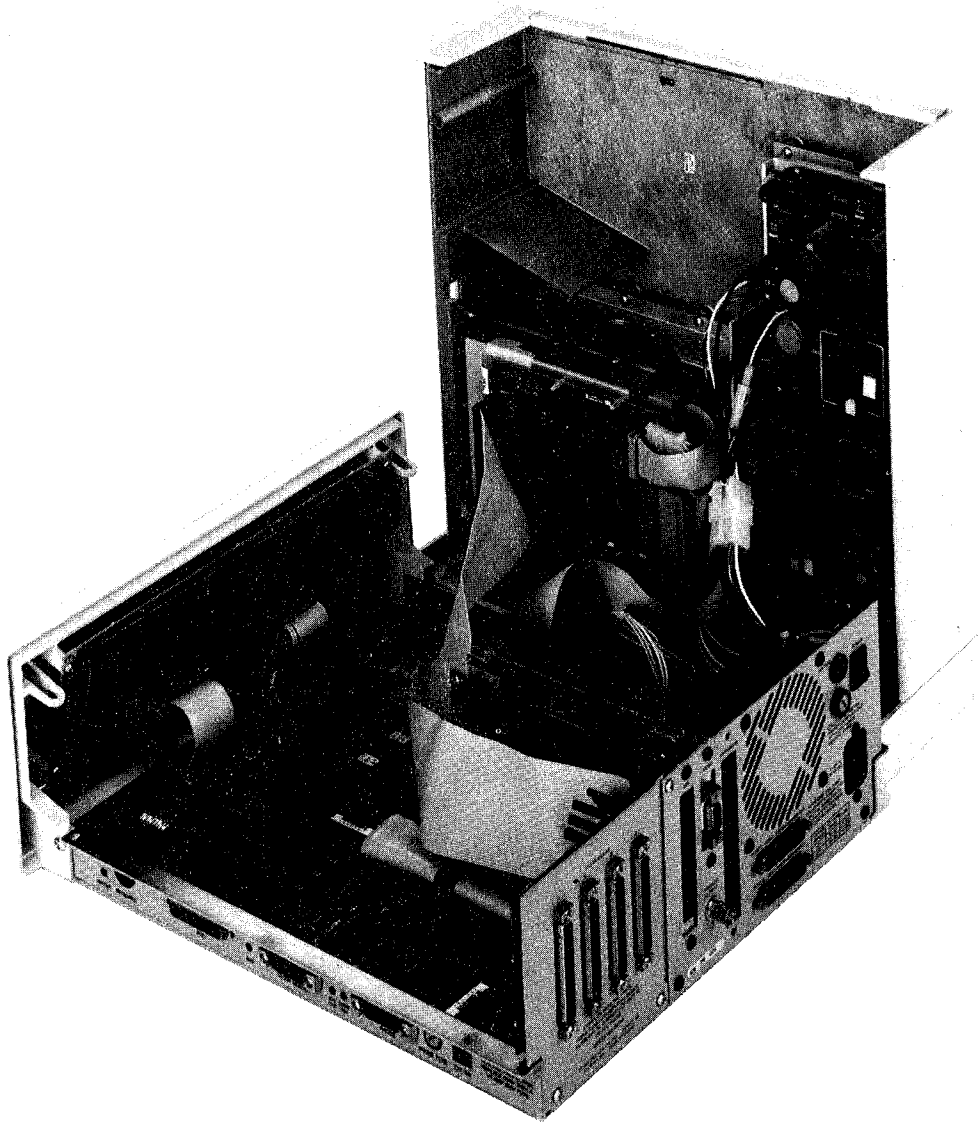

Note: Refer to system interconnect diagrams in Section 7 for electrical connection details.

Figure 4-3. Disassembly Details

4/Maintenance

If this Power Supply will not be reused in the same instrument, remove the back mounting plate. This plate adapts the Power Supply mounting requirements to those of the 9100A/9105A top cover.

Removing the MFI and Video Controller PCA

Remove the Multi-Function Interface (MFI) PCA, Video Controller PCA, or the Expansion PCA using the following procedure:

1. From the rear panel, remove the screws securing the pca.
2. To dislodge the pca from its connector, alternately lift first at the top-rear, then at the top-front.

Removing the I/O Connector Interface PCA

Remove the three screws securing the I/O Connector Interface mounting plate to the rear panel. Then pull the mounting plate and pca straight up. The pca can be detached from its mounting plate by removing the two screws securing each of the four I/O Module connectors.

Removing the Probe I/O Module Interface PCA

1. Remove the I/O Connector Interface PCA (see above).
2. Detach the ribbon cable connectors at J6 and J7. Grasp each connector at both ends and pull with a gentle end-to-end rocking action.
3. Detach the pca connector for the rear panel TRIGGER OUTPUT.
4. On the right side of the mainframe, remove two screws each for the CLOCK MODULE connector and the PROBE connector.
5. Now remove the four screws securing the pca in place.
6. Gently lift on the inside edge until the pca is detached from the remaining clip connection to the mainframe.

Removing the Main PCA

Use the following procedure for removing the Main PCA:

1. As appropriate, remove the MFI and Video Controller PCAs first.
2. Detach all connectors (8 to 10 places).
3. Remove the two connector locking posts from the pod connector on the right side of the mainframe.
4. Remove the five corner-retaining screws.
5. Gently work the Main PCA free of its mainframe retaining clips.

PROGRAMMER KEYBOARD ACCESS PROCEDURE

1. Place the keyboard on a soft pad to avoid scratching the keycaps.
2. Remove the six screws in the keyboard base plate using a Phillips screwdriver. Lift off the base plate.
3. Pull the keyboard cable connector (J3) off of the Encoder Printed Circuit Assembly (PCA).
4. Remove the ground connection, using a flat-blade screwdriver.
5. Gently pull out the three ribbon connectors from J1 and J2.
6. Remove the Encoder PCA attachment (four screws) from the keyswitch assembly using a flat-blade screwdriver.
7. Remove the keyswitch assembly from the keyboard case (four screws) using a flat-blade screwdriver.
8. To replace the keyboard components, reverse the above procedure. When replacing the three ribbon connectors, do not insert the clear acetate into the connectors.

Replace the keycaps by using the following procedure:

1. Use a flat-blade screwdriver to lift up the corner of the keycap, and lift the keycap off with your fingers.

Removing the keycap exposes a spring, a plunger, and a keyswitch base.
2. Keycaps slide on more easily if they are not pressed straight down.

To replace a keycap, position it over the plunger and press the bottom edge of the keycap down first, then press down the top edge.

NOTE

Some of the keycaps come completely off, leaving the plunger and spring on the keyswitch membrane. Other keycaps come off with the plunger still attached and the spring loose. To replace these keycaps, the plunger, spring and keycap must be properly aligned before they can be pressed down.

3. Replace the space bar using the following procedure:
 - a. Using a flat-blade screwdriver, lift off the space bar. This exposes a wire, plunger, spring, center post, and two corner posts.
 - b. If necessary, remove the wire, plunger and spring.

4/Maintenance

- c. Place the spring on the center post.
- d. Place the plunger on the spring. Press on the front edge and then the back edge of the plunger to work it into place on the center post.
- e. Slide the metal wire into the corner posts so that the wire rests over the center plunger and will depress the plunger when pressed.
- f. Turning the keyboard up to view it from an angle, snap the wire in place in the two depressions beneath the hooks on the underside of the bar. Use a screwdriver to assist you in snapping the wire into place.
- g. Press down on the space bar to lock it into place.

SCREEN OVERLAY

Recommended Use

The Contrast Enhancement Overlay enhances contrast and reduces reflection from external sources.

Removing the Overlay

To remove the overlay, spread the fingers of one hand and place your hand on the screen. Close your hand slightly, allowing the friction of your fingers to pull the overlay away from the screen.

Installing the Overlay

Use the following procedure to remove the Contrast Enhancement Overlay:

1. The overlay has adhesive on both tabs on the side opposite the matte surface. Remove the backing from the adhesive.
2. With the matte surface facing out, insert one overlay tab under the center of the lip at the top of the screen.
3. Insert the other overlay tab under the center of the lip at the bottom of the screen. Hold the overlay in place with your hand.
4. Slip the side of the overlay under the lip at the left side of the screen by simultaneously running your finger along the left edge of the overlay, and sliding the overlay under the screen lip.
5. Spread the fingers of your left hand to hold the left side, top, and bottom of the overlay in place. Use your right hand to insert the overlay right edge under the right edge of the screen lip.
6. Center the overlay. Press firmly directly over the tabs of the overlay to activate the adhesive.

MONITOR ACCESS, REMOVAL, INSTALLATION TECHNIQUES

The following instructions pertain to the Monochrome Monitor used with the 9100A Programmer's Station and Monochrome Video option.

Removing the Monitor Cover

1. Disconnect the line cord from the Monitor.
2. Use a Phillips screwdriver to remove the two screws along the bottom front and the single screw at the top rear.
3. Place the Monitor face down on a flat surface. To protect the screen from scratches, the surface must be covered with a soft cloth or pad.
4. Remove the four Phillips screws securing the tilt-base assembly to the Monitor. Rotate the assembly so that the hole found in the plastic foot successively allows access to each screw.
5. Pull the plastic Monitor case up and off.
6. Replace the Monitor case by reversing these steps.

Accessing the Monitor Chassis

1. Remove the five Phillips rear panel securing screws. Do not remove the power panel.
2. Place the Monitor screen face down on a flat surface that is protected by a soft cloth or pad.
3. Swing the bottom chassis cover open. The hinge will allow the chassis cover to open to 90 degrees.
4. To close the Monitor chassis, reverse the above procedure.

Removing the Front Bezel

1. Remove the monitor cover as described above.
2. Place the monitor chassis on a flat surface, with the front bezel extended over the edge of the work surface.
3. Locate the six front bezel connector holes. The connector holes are located on each side of the metal chassis, where the plastic snaps from the bezel are inserted in the chassis.
4. Insert a flat screwdriver into each of the connector holes, and push in to disengage the front bezel snaps. Maintain an outward force on the bezel to keep the snaps disengaged.
5. Lift the front bezel away from the chassis.

4/Maintenance

6. To reinstall the front bezel, position the bezel with the bezel snap fingers in line with the connector holes. Press in evenly on the bezel until all of the front bezel fingers snap into place.

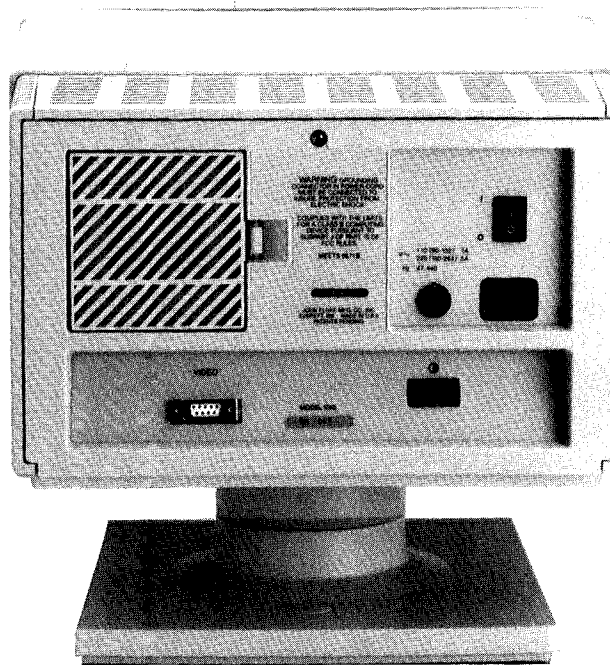

Figure 4-4. Monitor Rear Panel

Monitor Power Supply

REMOVING THE MONITOR POWER SUPPLY

WARNING

USE EXTREME CAUTION WHEN REMOVING THIS UNIT. THERE IS A DANGER OF ELECTRICAL SHOCK FROM HIGH VOLTAGE STORED IN CAPACITORS.

1. Lethal voltages may be present. Disconnect the power and wait 30 seconds before working with the power supply.
2. Open the chassis as described under the heading, "Accessing the Monitor Chassis".
3. Place the Monitor face down on a soft, level surface.
4. Disconnect the six wires that connect the power panel to the power supply. Refer to Figure 4-5 for wire locations.
5. Remove the power panel (two Phillips screws).
6. Remove the Phillips screw found in the rear corner of the Power Supply PCA.
7. Now work the Power Supply PCA loose from the three securing standoffs found in the remaining three corners.
8. Holding the Power Supply PCA in one hand, use the other hand to disconnect the power/video cable connector from the power supply. Be careful not to brush against the crt or yoke.
9. Remove the Power Supply PCA from the chassis.

NOTE

Do not discard the piece of foam that rests between the power supply and the chassis.

4/Maintenance

INSTALLING THE MONITOR POWER SUPPLY

The following installation procedure assumes that the existing Power Supply has already been removed:

1. Place the Monitor face down on a soft, level surface.
2. Install three new plastic standoffs into the square holes in the chassis top.

NOTE

Do not reuse plastic standoffs. Damage to standoffs may occur during removal without being clearly apparent. Fluke recommends that PCAs ALWAYS be equipped with new standoffs. All replacement modules are provided with new standoffs.

3. With the power/video cable connector directed toward the rear of the Monitor, connect the power/video cable to the power supply. The power/video cable connector may be fit over any two of the three sets of pins.
4. Reinsert the foam piece between the power supply and the chassis.
5. Place the power supply over the standoffs and press on the PCA to lock it in place. Install the Phillips screw in the rear corner of the pca.
6. Connect the power leads and ground. Refer to Figure 4-5 for wire connections.

NOTE

The mains wiring must not touch the secondary wiring (power/video cable). If wires touch, the unit will probably exceed conducted emissions limits. The power/video cable should be taut against the side of the chassis.

7. Replace the power panel.
8. Close the chassis cover.

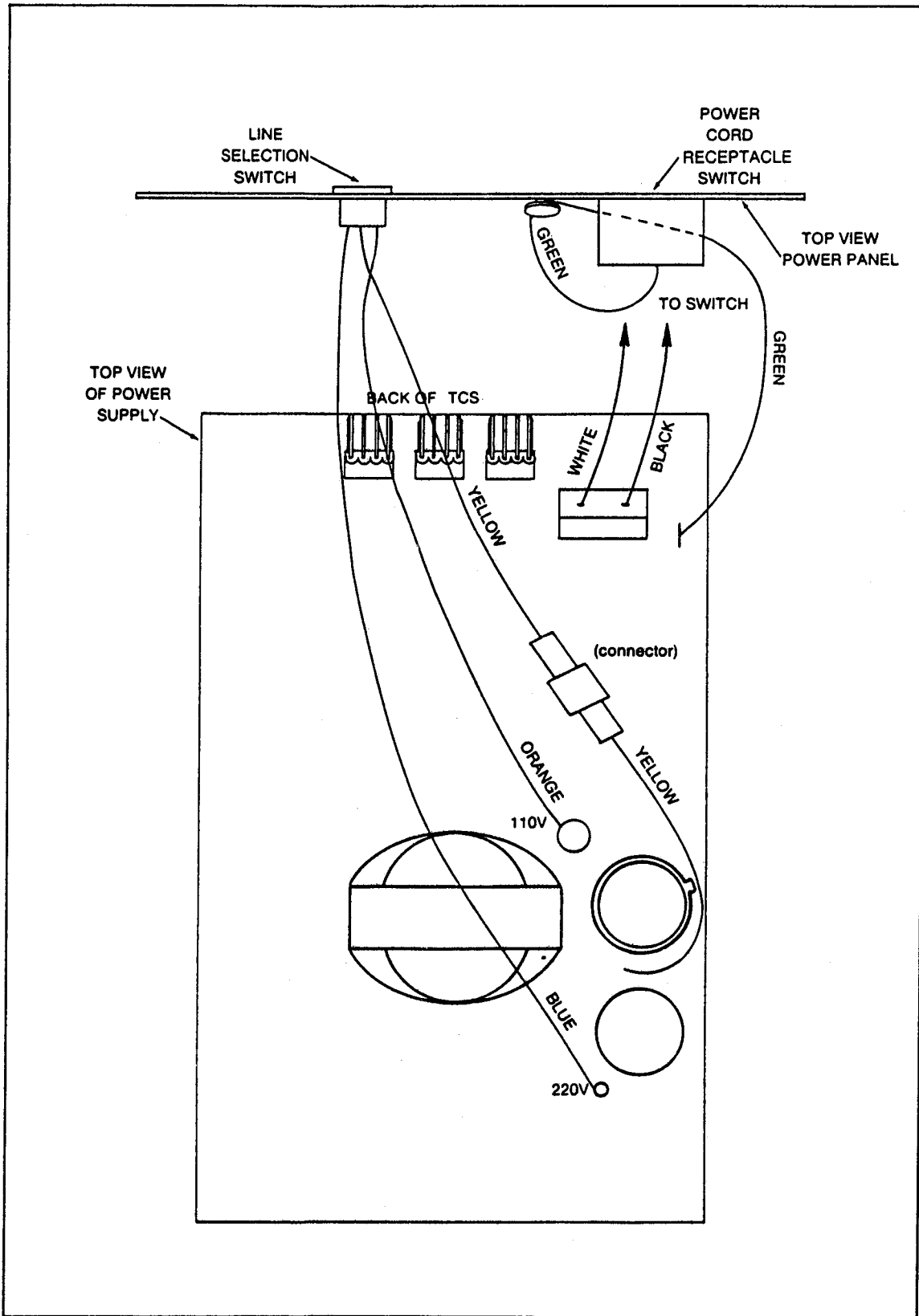

Figure 4-5. Power Supply Lead Connections

4/Maintenance

Monitor Display PCA

REMOVING THE DISPLAY PCA

NOTE

Fluke recommends replacing the crt when the Display PCA is replaced.

WARNING

TO REDUCE THE RISK OF ELECTRIC SHOCK ALWAYS TURN OFF THE TCS, DISCONNECT THE POWER CORD FROM THE PANEL ON THE REAR OF THE CHASSIS, AND WAIT ONE MINUTE BEFORE PROCEEDING WITH DISPLAY PCA REMOVAL.

WARNING

THE HIGH VOLTAGE SUPPLY MAY RETAIN A HIGH VOLTAGE CHARGE EVEN AFTER THE INSTRUMENT HAS BEEN TURNED OFF FOR SOME TIME. A CHARGE CAN BUILD UP ON THE CRT ANODE EVEN AFTER IT HAS BEEN DISCHARGED. THE CHARGE CAN DELIVER A SHOCK THAT COULD CAUSE THE CRT TO BE DROPPED, RESULTING IN AN IMPLOSION AND DANGEROUS FLYING GLASS.

1. Open the chassis as described under the heading, "Accessing the Monitor Chassis".

NOTE

Although the Display PCA uses a bleeder resistor, as a safety precaution assume that the resistor is nonfunctional.

2. Discharge the anode to the crt through a 1-megohm resistor as follows:
 - a. Connect one end of the resistor to the chassis with one clip lead.
 - b. Connect the other end of the resistor to the shaft of a 5-inch or longer screwdriver with a 1/4-inch tip, using another clip lead.
 - c. Hold the screwdriver by its plastic handle, and gently slip the tip under the edge of the anode connector on the crt end of the high-voltage lead; keep the blade flat against the glass envelope.
 - d. Slide the blade forward until the screwdriver blade touches the metallic clip at the end of the high-voltage lead. Be careful not to scratch the surface of the crt.

3. Remove the power/video cable connector from the Display PCA. Use both hands to pull the cable vertically away from the Display PCA.

Be careful not to bend the Display PCA. Refer to Figure 4-6 for the location of the power/video cable.

CAUTION

Bending the Display PCA can break solder joints and result in unreliable operation.

4. Working from the chassis exterior, remove the five standoff-securing screws for the Display PCA.
5. Locate the single black ground wire that attaches to the crt mounting bracket in the upper corner of the chassis. Pull the ground wire off the tab in the mounting bracket.
6. Gently pull the crt socket away from the end of the crt.
7. Disconnect the yoke wire connectors from the Display PCA.
8. Use a side-to-side motion to pry the anode on the crt loose from the anode connector. If necessary, use a non-conductive tool to help disengage the connector.
9. Remove the four PCA standoffs.
10. Remove the Display PCA with the anode and drive wires attached.

4/Maintenance

INSTALLING THE DISPLAY PCA

NOTE

Fluke recommends replacing the crt when the Display PCA is replaced.

WARNING

TO REDUCE THE RISK OF ELECTRIC SHOCK ALWAYS TURN OFF THE 9100A/9105A, DISCONNECT THE POWER CORD FROM THE PANEL ON THE REAR OF THE CHASSIS, AND WAIT ONE MINUTE BEFORE PROCEEDING WITH DISPLAY PCA INSTALLATION.

1. Open the chassis as described under the heading, "Accessing the Monitor Chassis".
2. Use a Phillips screwdriver to remove the two screws on the power panel. Disconnect the six wires that connect the power panel to the power supply. Refer to Figure 4-5 for wire locations. Remove the power panel.
3. Install the Display PCA using four standoffs. Be careful not to bend the Display PCA.

CAUTION

Do not bend the Display PCA. Doing so can break the solder joints and result in unreliable operation.

4. Replace the power/video cable connector in the Display PCA.
5. Snap the anode connector to the top of the crt.
6. Reattach the crt neck connector to the top of the neck of the crt. The connector is keyed to the pins.
7. Reconnect the yoke connectors.
8. Reattach the black ground wire to the tab on the crt mounting bracket beneath the X-ray warning on the chassis.
9. Reconnect the six wires that connect the power panel to the power supply. Refer to Figure 4-5 for wire locations. Replace the power panel.
10. Close the chassis cover as described under the heading, "Accessing the Monitor Chassis".

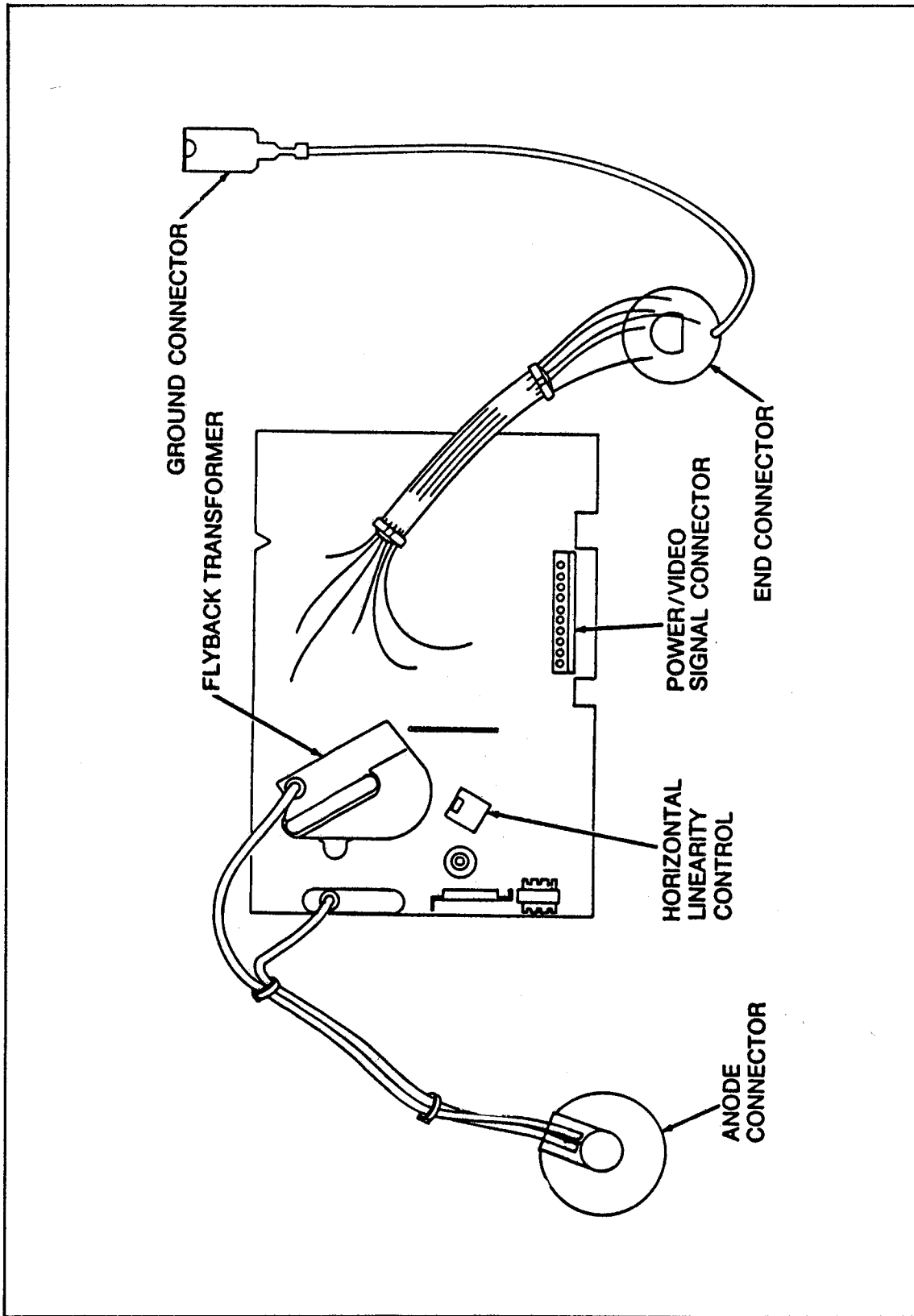

Figure 4-6. Display PCA

4/Maintenance

Crt and Yoke

REMOVING THE CRT AND YOKE

NOTE

Fluke recommends replacing the Display PCA when the crt is replaced.

WARNING

TO AVOID INJURY, USE CAUTION WHEN HANDLING THE CRT. WEAR PROTECTIVE CLOTHING AND SAFETY GLASSES OR A FULL FACE SHIELD. AVOID STRIKING THE CRT ON ANY OBJECT THAT MIGHT CAUSE IT TO CRACK OR IMplode. NEVER HANDLE THE CRT IN AN UNSAFE AREA, SUCH AS ONE WITH WET FLOORS OR HIGH ACTIVITY. NEVER HANDLE THE CRT AROUND OTHERS WHO MAY NOT BE PROPERLY PROTECTED. AVOID SCRATCHING THE TUBE OR CAUSING OTHER DAMAGE DURING INSTALLATION.

WARNING

TO REDUCE THE RISK OF ELECTRIC SHOCK ALWAYS TURN OFF THE 9100A/9105A, DISCONNECT THE POWER CORD FROM THE PANEL ON THE REAR OF THE CHASSIS, AND WAIT ONE MINUTE BEFORE PROCEEDING WITH CRT AND YOKE REMOVAL.

WARNING

THE HIGH VOLTAGE SUPPLY MAY RETAIN A HIGH VOLTAGE CHARGE EVEN AFTER THE INSTRUMENT HAS BEEN TURNED OFF FOR SOME TIME. A CHARGE CAN BUILD UP ON THE CRT ANODE EVEN AFTER BEING DISCHARGED. THE CHARGE CAN DELIVER A SHOCK THAT COULD CAUSE THE CRT TO BE DROPPED, RESULTING IN AN IMPLOSION AND DANGEROUS FLYING GLASS.

1. Discharge the anode to the crt through a 1-megohm resistor as follows:
 - a. Connect a resistor end to the chassis with clip lead.
 - b. Connect the other end of the resistor to the shaft of a 5-inch or longer screwdriver with a 1/4-inch tip, using another clip lead.
 - c. Hold the screwdriver by its plastic handle, and gently slip the tip under the edge of the anode connector on the crt end of the high-voltage lead; keep the blade flat against the glass envelope. Slide the blade forward until the screwdriver blade touches the metallic clip at the end of the high-voltage lead. Be careful not to scratch the surface of the crt.

2. Disconnect and remove the Display PCA as follows:
 - a. Gently pull the crt socket away from the end of the crt.
 - b. Disconnect the yoke wire connectors from the Display PCA.
 - c. Use a side-to-side motion to pry the anode on the crt loose from the anode connector. If necessary, use a non-conductive tool to help disengage the connector.
 - d. Remove the four pca standoffs.
 - e. Remove the Display PCA with the anode and drive wires attached.
3. Use a Phillips screwdriver to remove the two screws on the power panel.
4. Disconnect the six wires that connect the power panel to the power supply. Refer to Figure 4-5 for wire locations. Lift off the power panel.
5. Remove the front bezel (see "Removing the Front Bezel", earlier in this section.)
6. Use a Phillips screwdriver to remove the eight outside screws from the four crt mounting brackets. Remove the tab from the crt mounting bracket at the corner of the crt.
7. Remove the dust gasket.
8. With the crt face down (on a soft, level surface), lift the chassis off the crt. Be careful not to scratch any part of the crt!
9. Place the crt on a soft, level surface.

4/Maintenance

INSTALLING THE CRT AND YOKE

NOTE

Fluke recommends replacing the Display PCA when the crt is replaced.

WARNING

TO AVOID INJURY, USE CAUTION WHEN HANDLING THE CRT. WEAR PROTECTIVE CLOTHING AND SAFETY GLASSES OR A FULL FACE SHIELD. AVOID STRIKING THE CRT ON ANY OBJECT THAT MIGHT CAUSE IT TO CRACK OR IMplode. NEVER HANDLE THE CRT IN AN UNSAFE AREA, SUCH AS ONE WITH WET FLOORS, HIGH ACTIVITY, ETC. NEVER HANDLE THE CRT AROUND OTHERS WHO MAY NOT BE PROPERLY PROTECTED. AVOID SCRATCHING THE TUBE OR CAUSING OTHER DAMAGE DURING INSTALLATION.

WARNING

TO REDUCE THE RISK OF ELECTRIC SHOCK ALWAYS TURN OFF THE 9100A/9105A, DISCONNECT THE POWER CORD FROM THE PANEL ON THE REAR OF THE CHASSIS, AND WAIT ONE MINUTE BEFORE PROCEEDING WITH CRT AND YOKE INSTALLATION.

WARNING

THE HIGH VOLTAGE SUPPLY MAY RETAIN A HIGH VOLTAGE CHARGE EVEN AFTER THE INSTRUMENT HAS BEEN TURNED OFF FOR SOME TIME. THE CHARGE CAN DELIVER A SHOCK THAT COULD CAUSE THE CRT TO BE DROPPED, RESULTING IN AN IMPLOSION AND DANGEROUS FLYING GLASS.

The Display PCA and power panel must be removed prior to crt installation.

1. With the crt face down on a soft, level surface and the anode facing away from you, loosely install the four crt brackets to the four crt mounting ears and crt grounding clip (step 2).

CAUTION

Do not move the magnets on the crt yoke.

2. Insert the crt grounding clip under the screw on your right, closest to you. Insert the ground wire tab into the clip.
3. Carefully insert the chassis over the crt with the anode connection on the crt positioned toward the top of the unit.

4. Use a Phillips screwdriver to install and loosely tighten the eight exterior screws on the four crt mounting brackets.
5. Approximately center the crt. Use a long-bladed screwdriver to tighten the four screws that attach the crt to the crt mounting bracket.
6. Push the crt as far forward as possible into the chassis and tighten the exterior screws.
7. Clean the crt with alcohol or another suitable cleaner.
8. Reinstall the Display PCA as described above.
9. Reinstall the dust gasket.
10. Reinstall the front bezel.
11. Reconnect the six wires that connect the power panel to the power supply. Refer to Figure 4-5 for wire locations. Reinstall the power panel by replacing the two screws.
12. Perform the procedure under the heading "Monitor Adjustment."
13. Close the chassis cover.

MONITOR ADJUSTMENT

NOTE

Display tilt may be slightly affected by the orientation of the Monitor, especially in environments containing a high density of metal. Rotate the unit and try to find a position where the tilt is in the center between extreme clockwise tilt and extreme counterclockwise tilt. Perform alignment and adjustment in that position. If no difference is perceived between the two extremes, proceed in the most convenient orientation.

NOTE

Magnetic alignment is accomplished with alignment magnets. Magnets should not be removed or added to the crt yoke. The displays are prealigned. Due to handling, however, a magnet may be rotated off position. Rotate the magnets to improve alignment **ONLY IF ABSOLUTELY NECESSARY**. It should not be necessary to use the centering rings on the yoke to align the display.

CAUTION

Turning the Monitor on with line voltage higher than 132V ac when the line voltage selection switch is in the 110 position will damage the power supply. If the voltage is set for 180 to 264V and 90 to 132V is applied, the unit may not operate.

NOTE

Allow the Monitor to warm up for at least 10 minutes. During the first 5 minutes of operation, raster lines may be visible on the display. This is common to crt displays and is not a fault.

The display can be adjusted using a program-generated monitor alignment pattern. The pattern consists of four outlined boxes, two across and two down. Each box is 40 characters wide by 12 lines high. Table 4-3 contains the required monitor alignment program. An alignment pattern can also be generated by a program on the 9100A Service Utility disk, which is part of the 9100A Service Kit (see Troubleshooting).

This program is used with the Alignment Template, P/N 777144. When the display is properly adjusted, the four boxes displayed by the program fit evenly and symmetrically within the inner lines of the template.

Table 4-3. Monitor Alignment Program

```
program alignment
```

```
!*****
!* This program generates an alignment pattern on the monitor. The      *
!* pattern consists of four outlined boxes, two across and two down;    *
!* each box is 40 characters wide and 12 lines high.                    *
!*****

HL9 = "\8A"+" \8A"+" \8A"+" \8A"+" \8A"+" \8A"+" \8A"+" \8A"+" \8A" ! 9 horiz. lines
Top_s = "\86"+" \8A"+ HL9 + HL9 + HL9 + HL9 +" \8A"+" \8C" ! top of box string
Bot_s = "\83"+" \8A"+ HL9 + HL9 + HL9 + HL9 +" \8A"+" \89" ! bottom of box string
Ctr_s = "\85                                     \85" ! center of box string
EoS_s = "\1B[2;30H Monitor \1B[4C Alignment \1B[10B" ! End of Screen string
L12_s = ""                                         ! Line 12 string

open device "/term2", as "output"           ! open channel to print to monitor

print using "\1B[H\1B[J"                   ! cursor to top left, and clear monitor screen

loop for s = 0 to 1                         ! do top half and then bottom half of pattern
  print Top_s,Top_s                         ! print top line of left and right boxes
  loop for l = 2. to 11.
    print Ctr_s,Ctr_s                       ! fill in center of left and right boxes
  end loop
  if s > 0 then L12_s = EoS_s               ! if this is the End of the Screen, then
                                           ! need to print title and position cursor.
  print Bot_s,Bot_s,L12_s                  ! print bottom line of left and right boxes

end loop                                     ! if this was the top half, do the bottom

end program
```

4/Maintenance

Alternately, any monitor display pattern can be used when the programmed pattern is not available. This method involves display and adjustment of the monitor screen for a centered display of the correct size. The alternate pattern used must measure 80 columns wide by 24 rows high to allow for correct adjustment.

The monitor display is adjusted using the following seven controls:

- o Vertical Linearity
- o Vertical Size
- o Brightness
- o Focus
- o Horizontal Phase
- o Horizontal Size
- o Horizontal Linearity
- o Contrast

The first six of these controls can be adjusted externally through holes in the monitor chassis (shown in Figure 4-7). Adjusting horizontal size requires hex adjustment tool (P/N 572321). Contrast is an external operator adjustment. Adjusting all other controls requires the use of an adjustment tool (P/N 800540).

The monitor chassis must be opened to adjust the Horizontal Linearity control. Refer to "Accessing the Monitor Chassis". Adjusting the Horizontal Linearity control requires the use of the hex adjustment tool (P/N 572321).

As some adjustments may interact with others, repeating the procedure may be necessary. For either display method, use the following steps to adjust the display:

1. If necessary, remove the monitor cover. Then, locate the external display adjustment holes. See Figure 4-7.
2. Cover a flat surface with a soft cloth to protect the monitor screen. Place the Monitor face down.
3. Open the Monitor by using a Phillips screwdriver to remove the five screws on the rear panel. Swing the bottom chassis cover down. Do not remove the power panel.

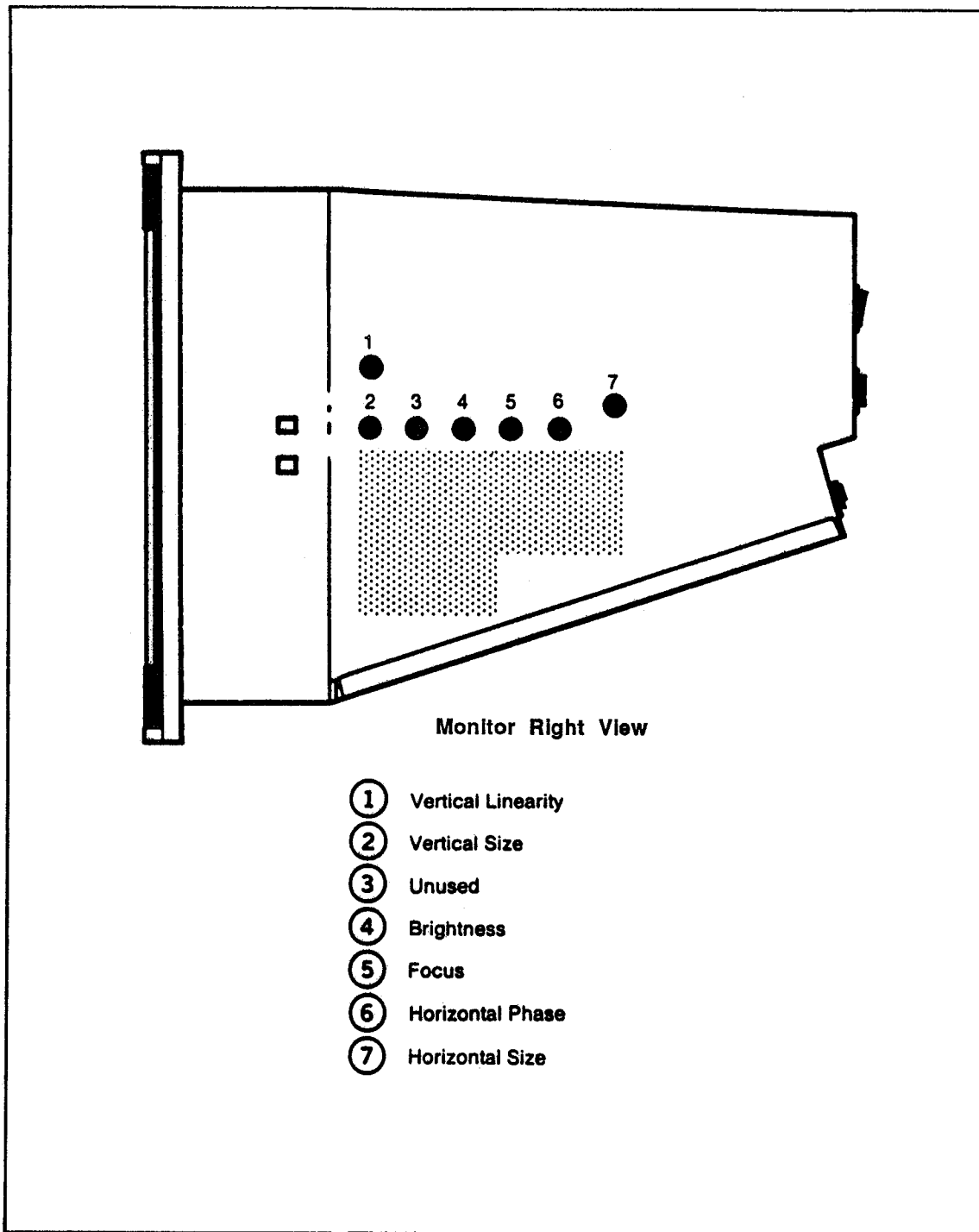

Figure 4-7. External Display Adjustment Locations

4/Maintenance

4. Perform the following yoke adjustment only if the screen appears tilted.
 - a. Loosen the clamp around the yoke of the crt using a 3/16-inch nut driver.
 - b. Turn the Monitor so that the display can be seen.
 - c. Rotate the yoke slightly to adjust for the screen tilt.
- d. Check that the tightening screw is easily accessible, then tighten the clamp to a torque of 6 inch-pounds (0.678 n-m). Do not overtighten the screw, or the neck of the crt may crack.

WARNING

TO AVOID INJURY, USE CAUTION WHEN HANDLING THE CRT. WEAR PROTECTIVE CLOTHING AND SAFETY GLASSES OR A FULL FACE SHIELD. AVOID STRIKING THE CRT ON ANY OBJECT THAT MIGHT CAUSE IT TO CRACK OR IMplode. NEVER HANDLE THE CRT IN AN UNSAFE AREA, SUCH AS ONE WITH WET FLOORS, HIGH ACTIVITY, ETC. NEVER HANDLE THE CRT AROUND OTHERS WHO MAY NOT BE PROPERLY PROTECTED. AVOID SCRATCHING THE TUBE OR CAUSING OTHER DAMAGE DURING INSTALLATION.

NOTE

Display tilt may be slightly affected by the orientation of the Monitor, especially in environments containing a high density of metal. Rotate the unit and try to find a position where the tilt is in the center between extreme clockwise tilt and extreme counterclockwise tilt. Perform alignment in that position. If no difference is perceived between the two extremes, proceed in the most convenient orientation.

5. Locate the Horizontal Linearity control on the Display PCA (see Figure 4-7.) Adjust Horizontal Linearity so that the left half of the display is the same size as the right half of the display. Since the open chassis cover has a slight effect on Horizontal Linearity, close the chassis cover to verify Horizontal Linearity and keep it closed for the remainder of the procedure. Linearity is also slightly affected by the unit being upside down.

6. Adjust Horizontal Phase to line up the center gaps between the boxes with the alignment centering marks on the bezel. If an alternate pattern is being used, use Horizontal Phase to center the display.
7. Adjust Vertical Linearity so that the boxes (or regions of the alternate pattern) appear the same.
8. Adjust Vertical Size to make the alignment pattern (or alternate pattern) about 5 1/8 inches (130 mm) high.
9. Adjust Horizontal Size to make the alignment pattern (or alternate pattern) about by 7 3/4 inches (195 mm) wide.
10. Set the Brightness control for a slight amount of "blooming" with the Contrast (external operator control) set to maximum.
11. Adjust the Focus control with Contrast set for normal viewing.
12. Use a Phillips screwdriver to replace the five rear panel screws.

NOTE

If the Monitor was adjusted with the unit upside down, a final Horizontal Phase adjustment will probably be necessary.

13. Reinstall the monitor cover.

DECIDING ON CRT REPLACEMENT

The crt should be replaced if any of the following occur:

- o If an image has been burned into the phosphor and the image on the display is unacceptably altered.
- o If scratches are detectable by a pass of the finger. (Scratches can create a safety hazard that lessens the ability of the crt to withstand implosion.)

The crt may require replacement when any of the following occur:

- o Ghost images appear on the display.
- o Brightness levels are unacceptable.

NOTE

Insufficient brightness can be caused by several factors. After 10,000 hours of continuous excitation of the phosphor, crt brightness can be expected to have dropped by approximately 50 percent. Failures in the Display PCA can also cause loss of brightness.

4/Maintenance

A properly functioning crt requires ten minutes to warm up completely. During the first five minutes, raster lines may appear on the display. This is common to crt displays and is not a fault. If the display takes more than five minutes to achieve full brightness, suspect either a crt or Display PCA failure.

NOTE

Monitors are preset at the factory for the same brightness at maximum contrast. Due to crt variations, the Display PCA brightness control will not be in the same position for all units and the raster may be visible for varying amounts of time, if at all.

NOTE

Because the maximum brightness of the crt will vary from unit to unit, the decision to replace a display on the basis of insufficient brightness is subjective.

SELF TEST ROUTINES

Power-Up Self Test

At power-up, the 9100A/9105A sequences through a series of self tests. A display response is presented for any test that fails. These responses (and related meanings) are presented in Table 4-4. In addition, a Mainboard ROM and Display Response test is run. A failed test in this instance is evidenced by simultaneously flashing RUN UUT and DISK ACCESS LEDs.

Probe Self Test

The Probe Self Test verifies that the Probe is connected and is communicating with the system. Use the following procedure:

1. Press the MAIN MENU key.
2. Press the left arrow (<-->) key until the cursor rests on the first (left-most) field. Then, with the cursor on this field, press the SELFTEST key.
3. Press the right arrow (-->) key to move the cursor to select the next field, then press the PROBE key. Check that the display reads:

MAIN: SELFTEST PROBE

4. Press the ENTER key to initiate the self test.
 - o If the self test fails, a failure message is displayed. Check the probe connection and repeat the test.
 - o If the test fails a second time, the Probe requires service.

 Table 4-4. Power-Up Self Test Responses

selftest: testing memory . . .

This message is displayed during the simple read/write test of the RAM.

-----Press any key to continue test-----
 or the RESET key for the next test

If an error was detected during the RAM test, pressing the RESET key aborts the RAM test and sequences the 9100A/9105A to the next test in the power-up self test series. Pressing any other key continues the test at the next higher RAM location.

selftest: ram read/write error @

A RAM read/write test has failed at the specified address. The memory test itself is extremely primitive. A long word with a value of '5a5a5a5a' is written and read back, followed by a long word with the value 'a5a5a5a5'. Any bit that cannot be written either high or low is considered defective.

selftest: r/w error on pod cmd port:

Of the command bits that are tested on the pod port, one or more have failed a read/write test. The mask of the failing bit(s) is displayed in hex.

selftest: r/w error on pod data port:

One or more bits in the pod data port have failed a read/write test. An error mask of the offending bit(s) is displayed in hex.

**selftest: data error in uart u7
 should be: xxxx not: xxxx**

An error occurred while the UART was in its digital loopback self-test mode. The data written has not matched the data read in device U7, and the two datum are displayed on the second line of the display.

**selftest: data error in uart u12
 should be: xxxx not: xxxx**

An error occurred while the UART was in its digital loopback self-test mode. The data written has not matched the data read in device U12, and the two datum are displayed on the second line of the display.

selftest: timed out waiting for uart

One of the UART transmit registers has not cleared in a reasonable amount of time. The UART clock could be disabled, or the chip itself could be bad.

Table 4-4. Power-Up Self Test Responses (cont)

selftest: probe i/o board not responding

A simple read/write test to both of the gate array chips on the Probe I/O PCA has failed.

selftest: ram test bus error@

An unexpected bus error occurred during the power up RAM test. This could be a result of setting the RAM size in the EEPROM too large, or it could be a problem with the memory decoding circuitry.

selftest: front display not responding

The front panel display processor has not returned the expected character within a reasonable amount of time.

selftest: probe i/o stop counter failure

The high speed stop counter in the start-stop logic has failed. To test the stop counter on the Probe I/O PCA the counter is soft clocked and checked for proper response. The counter is preset to a value of two. The clock is soft stepped once and the stop counter is checked to insure it has not triggered. Another clock is produced and the stop counter is checked for an active condition.

selftest: probe i/o logic chip inactive

In the process of setting up the stop counter test, it is necessary to set the start-stop state machine inside the U19 gate array to state 1 (start received, waiting for stop). If the state machine is not in state 1 after clocking, an error is assumed somewhere in the start-stop logic subsection.

selftest: floppy controller failure

A simple read/write test to several of the floppy controller registers has failed.

selftest: floppy controller not responding

A bus error occurred while trying to read or write the floppy controller.

Table 4-4. Power-Up Self Test Responses (cont)

selftest: stuck vector:

The floppy controller is given a force interrupt command. If the resultant vector is not the floppy controller interrupt vector, then it is assumed that another interrupt is active. At this point in the self test, no interrupts should be active, and this is considered an error. The force interrupt command is followed by a reset interrupt command. After this command no interrupts should be active, and any active interrupts are again considered error conditions. In both conditions the number reported is the actual physical vector address.

selftest: uarts not responding

A bus error occurred while trying to read or write either of the UART devices.

selftest: front display ram test failure

An error code was returned by the front panel display when asked to perform an internal RAM test.

Pod Self Test

This test performs a comprehensive pod check. Test failure is evidenced by an error message. (See the respective pod manual for full error descriptions). Proceed as follows:

1. Make all connections. Ensure that the Pod is attached to the mainframe and that the pod UUT connector is inserted and locked into the pod self-test socket. The pod manual and the 9100A/9105A Getting Started guide illustrate these connections further.
2. On the 9100A/9105A, first press MAIN MENU, then move the cursor to the first (left-most) field using the left arrow (<--) key.
3. Press the SELFTEST key.
4. Move the cursor one field to the right and press POD. Check that the display reads:

MAIN: SELFTEST POD
5. Press ENTER to initiate the self test.
 - o If the self test fails, a failure message is displayed. Check the pod connection and repeat the test.
 - o If the test fails a second time, the Pod requires service.

4/Maintenance

I/O Module Self Test

The I/O Module Self Test verifies that the I/O Module is connected and is communicating with the system. Use the following procedure:

1. Press MAIN MENU, then move the cursor to the first (left-most) field using the left arrow (<-->) key.
2. Press SELFTEST.
3. Move the cursor one field to the right and press I/O MOD.
4. Move the cursor one more field to the right, and press the number of the I/O Module to be tested. Check that the display reads:

```
MAIN: SELFTEST I/O MOD <n>
```

(where <n> signifies the number of the I/O Module)

5. Press ENTER to initiate the self test.
 - o If the self test fails, a failure message is displayed. Check the I/O Module connection and repeat the test.
 - o If the test fails a second time, the I/O Module requires service.

Display Self Test

Several software tests aid in testing the Display Board. Each test can be selected by a command sent through the display processor serial port. The "Test" command, 0x0e, followed by a test number ascii 1-9 (or 0x31-0x39) selects the test.

The tests are available through a program in the 9100A Service Kit. They can also be initiated using a 68000 Pod plugged into the mainframe. The Pod must initialize the DUART before sending the serial command to the Display Board. These tests are not available through TL/1; the Control N (0x0e) command is not sent to the display.

Tests 1 (ROM) and 2 (RAM) are also performed by mainframe software during the mainframe self test following a reset. At this time, the mainframe also performs Test 9 (look for Synchronous Special Function key) to determine if a boot should be forced off the floppy drive instead of the hard disk.

Tests 4, 5, and 6 are useful for troubleshooting the keyscan and display refresh hardware. They are available by grounding Test Point 6 (TP6) during a reset, as well as by software control.

All display tests are listed and described in Table 4-5.

Table 4-5. Display Self Test

Test 0 - Sends Out Software Revision Number

The number is returned to the serial port just like a key press.

Test 1 - Verifies ROM Internal Checksum

Returns 0x70 (p) to the serial port if test passed, 0x71 (q) if it didn't.

Test 2 - Performs Quick RAM Test

This is a non-destructive test of the Display RAM. It writes the compliment of the present data, reads it back, re-writes the original data, and then reads that back. Returns 0x72 (r) to the serial port if the test passed, 0x73 (s) if it didn't.

Test 3 - Performs Long RAM Test

This is a more complete, destructive test of the Display RAM. It performs a test similar to the 9100 RAM FAST on the RAM and returns 0x74 (t) to the serial port if the test passed, or 0x75 (u) if the test did not pass.

NOTE

Tests 4, 5, and 6 cause the software to exit mainframe control. The Display Board does not respond to further commands or data until the test is exited by keyboard control or by a reset. All three tests are destructive, in that they write over the present display.

Also, tests 4, 5, and 6 can be accessed by grounding the TEST testpoint and resetting (or powering on) the display.

Test 4 - Jump to Key Test Routine

This is the mode entered when TP6 is grounded during a reset. This test displays the row and column of the key being pressed on the display.

The RESET key causes this test to terminate and Test 5 to start.

Table 4-5. Display Self Test (cont)

Test 5 - Jump to Display Lines Routine

The following key-pattern relationships are applicable during this test:

- o Keys 1, 2, and 3 each display a vertical bar in every third column. For example, key 1 display bars in columns 1, 4, 7, and so on. Keys 2 and 3 control columns beginning at 2 and 3, respectively.
- o Keys 4, 5, and 6 display a series of horizontal bars, also spaced three lines apart.
- o Key 0 turns all lines off (blank display).
- o Key 7 turns all lines on and is the default when test 5 is entered.

NOTE

This mode is useful if the display has a "burned in" problem. Since this mode does not time out, leaving the display in this mode overnight makes for a more even display.

- o The EXEC Key returns to Test 4.
- o The ALPHA Key jumps to Test 6.
- o The RESET Key exits these tests entirely and returns the display to mainframe control.

Test 6 - Jump to V-H Lines Routine

This routine identifies the bad grid drivers or row drivers. The arrow keys are used to move among the displayed cross hairs. Pressing the HELP key displays the names of the two grids and one row driver which should be on to illuminate the dot at the intersection of the cross hairs. The RESET Key returns to Test 5.

Test 7 - Unlock Keyboard

If the keyboard has been locked by test 8, this command re-enables the key scan. It returns 0x76 (v) as an acknowledge byte.

Table 4-5. Display Self Test (cont)

Test 8 - Lock Keyboard

This command disables key scan and prevents the display board from sending any key press information. It is used by the mainframe to ensure that only test routine data is received. It returns 0x77 (w) as an acknowledge byte.

Test 9 - Report Synchronous Special Function Key

This function returns a 0x79 (y) if the processor has seen the special function key press since the last inquiry or reset. It returns a 0x78 (x) if it has not seen it. The Special function results from the SOFT KEYS, F2, and F4 keys being pressed simultaneously.

CALIBRATION

Individual level and time delay variations associated with the Probe, I/O Module, and Pod can be compensated for with the calibration adjustments presented in the following paragraphs. The following six calibrations are covered:

- o Probe offset correction calibration
- o Probe compensation calibration
- o Probe to external clock module calibration
- o Probe to Pod calibration
- o I/O Module external calibration
- o I/O Module to Pod calibration

The calibrations listed above fall into three categories. Offset correction calibration stores a correction value in non-volatile memory. Compensation calibration matches impedances. Data against clock delay calibration, performed in software, ensures that both data and the signal clocking the data arrive at the receiving hardware at the same time.

Probe compensation remains stable and is necessary only when a Probe is first connected to the mainframe. The software calibration procedures are intended to be performed by the system operator and do not require any test equipment.

4/Maintenance

Software calibration should be performed when the system is first set up and at regular intervals (at least monthly) thereafter. Calibration is also necessary whenever devices attached to the system are changed or repaired.

The system can also be calibrated by restoring data generated by previous calibrations. This process, described under "Saving and Restoring Calibration Data" later in this section, should be performed after each power-up or reset and before UUT testing or troubleshooting.

Probe Offset Correction

Probe offset correction calibration calculates the offset voltage of the Probe input circuitry and stores the value in an EEPROM. This procedure is required only if the Probe I/O or Main PCAs are repaired or replaced.

A utility program is required to perform the probe offset correction calibration. This utility program is included on the 9100A Service Utility disk, which is part of the 9100A Service Kit (see Troubleshooting).

Probe Compensation

This calibration procedure matches the impedance of the Probe to that of the cable connecting the Probe to the system. Probe impedance is adjusted with COMP ADJ, a trimmer capacitor located on the side of the system.

Figure 4-8 shows oscilloscope connections used during probe compensation. To compensate the Probe, use the following steps:

1. Ensure that the oscilloscope and its Probe are properly calibrated.
2. Connect the oscilloscope probe tip to the system CAL OUT post. Then connect the oscilloscope probe common to the system GND post. Both posts are accessible through labeled holes in the side of the mainframe.
3. Press the MAIN MENU key, and use the left arrow key to move the cursor to the left-most field.
4. Press the CAL softkey.
5. Use the right arrow key to move the cursor to the next field, and press the PROBE softkey.
6. Move the cursor to the next field, and press the COMP softkey. The display should now read:

```
MAIN: CAL PROBE COMP
```

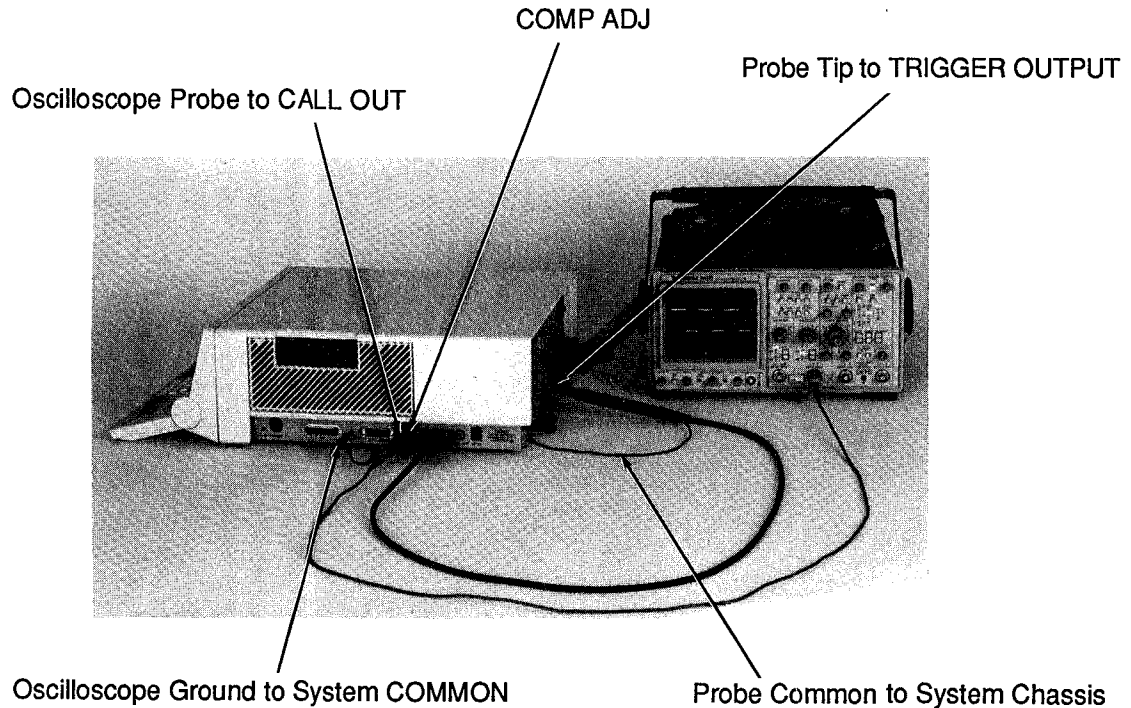



Figure 4-8. Oscilloscope Use in Probe Compensation

7. Press the ENTER key. The display should read:

```
MAIN: CAL PROBE COMP
CONNECT PROBE TO TRIGGER OUTPUT
ADJUST COMP, PRESS STOP WHEN DONE
```

8. Insert the probe tip into the central (innermost) conductor of the TRIGGER OUTPUT at the rear of the 9100A/9105A. Leave the Probe in this position.
9. Adjust the oscilloscope's horizontal and vertical settings until an approximate square wave is displayed. Then use an adjustment tool on COMP ADJ to obtain an underdamped square wave with 10% overshoot. For the adjustment tool, use Fluke Part Number 800540. The square wave should bear similarity to Figure 4-9.
10. When you have finished the square wave adjustment, press the STOP key on the operator's keypad. The display should read:

```
MAIN: CALIBRATION COMPLETE
```

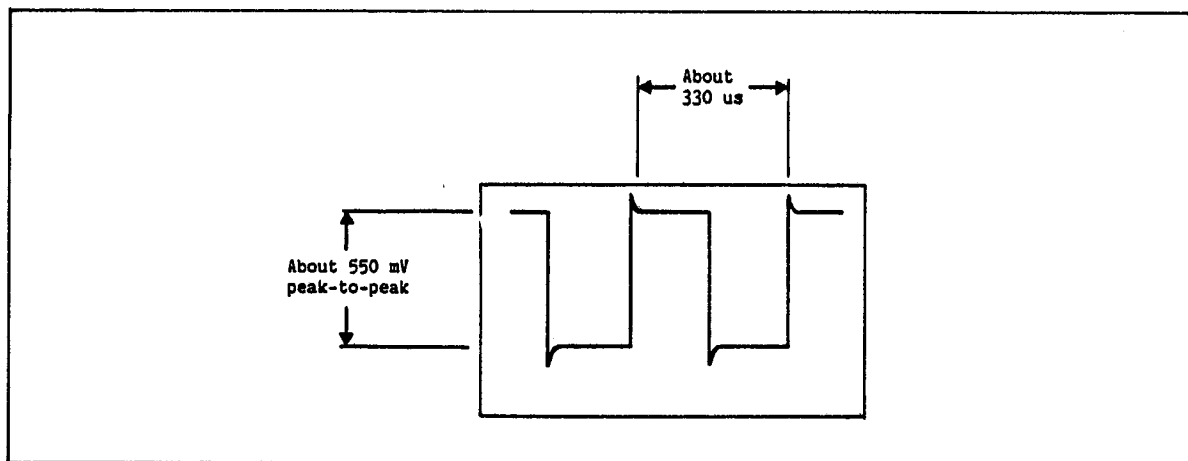

Figure 4-9. Probe Compensation Square Wave

Software Calibration

The Probe Compensation adjustment and the Probe Offset Calibration are the only hardware calibrations required for the 9100A/9105A. All other calibration is performed in software and is lost if the system is turned off, restarted, or reset. The software calibration data can be saved on disk and restored from disk to recalibrate the system. However, the restored calibration data must only be used with the system on which the calibration was performed. Any change in system hardware (Interface Pod, I/O Module(s) Clock Module, or Probe) requires system recalibration; the resulting new calibration data should be saved.

All of the software calibration procedures are intended to be performed by the system operator and do not require test equipment. Pod-related calibration procedures require the use of a known good Unit Under Test (UUT).

PROBE TO EXTERNAL (CLOCK MODULE)

This calibration automatically calibrates the Probe's internal data delay to the external clock delay. The clock signal input is through the Clock Module, which must be connected to the system. Perform the calibration as follows:

1. Press the MAIN MENU key, and use the left arrow key to move the cursor to the left-most field.
2. Press the CAL softkey.
3. Move the cursor to the next field, and press the PROBE softkey.
4. Move the cursor to the next field, and press the TO EXT softkey. The display should read:

MAIN: CAL PROBE TO EXT

5. Press the ENTER key. The display should read:
 MAIN: CAL PROBE TO EXT
 CONNECT EXTERNAL CLOCK TO PROBE TIP AND
 COMMON LINES TOGETHER. PRESS BUTTON.
6. Connect the Probe to the Clock Module CLOCK line.
7. Connect the probe ground clip to the Clock Module COMMON line.
8. Press the probe ready button (side of Probe). The display should read:
 MAIN: CALIBRATION COMPLETE

PROBE TO POD

This procedure automatically calibrates the Probe's internal data delay to the Pod's PodSync line, which the system sometimes uses as a clock signal. Use the following steps to perform the calibration:

1. Connect the Pod to a UUT.
2. Press the MAIN MENU key, and use the left arrow key to move the cursor to the left-most field.
3. Press the CAL softkey.
4. Move the cursor to the next field, and press the PROBE softkey.
5. Move the cursor to the next field, and press the TO POD softkey. The display should read:

MAIN: CAL PROBE TO POD ADDR

The last field is pod dependent and softkey selectable.

6. Press the ENTER key. The display asks you to probe the UUT at a point where the selected PodSync appears. The message is pod dependent, a possible example being:
 MAIN: CAL PROBE TO POD ADDR
 CONNECT PROBE TO ALE
 PRESS PROBE BUTTON WHEN READY
7. Connect the probe common clip to the UUT common.
8. Probe the specified pod line as directed. You may need to refer to the UUT schematic for convenient probing locations.
9. With the probe tip touching the point being probed, push the probe ready button.

4/Maintenance

10. You may have to repeat steps 8 and 9, probing at different locations each time. When calibration is complete, the display should read:

MAIN: CALIBRATION COMPLETE

11. Repeat steps 5 through 10 for each SYNC mode in which the 9100A/9105A is to be operated.

I/O MODULE TO EXTERNAL

This procedure calculates the proper setting for the I/O Module's internal clock delay for use whenever the SYNC I/O MOD TO EXT command is entered. This calibration requires the use of the Calibration Module supplied with the I/O Module. To perform the calibration:

1. Press the MAIN MENU key, and use the left arrow key to move the cursor to the left-most field.
2. Press the CAL softkey.
3. Move the cursor to the next field, and press the I/O MOD softkey.
4. Move the cursor to the next field, and press the EXT softkey. The display should read:

MAIN: CAL I/O MOD TO EXT

5. Press the ENTER key. The display should read:

MAIN: CAL I/O MOD TO EXT
INSTALL CAL HEADER IN DESIRED I/O MODULE
PRESS BUTTON WHEN READY

6. Fit the Calibration Module over the I/O Module to be tested.
7. Press the ready button on the Calibration Module. When the calibration is complete, the BUSY light should go off, and the display should read:

MAIN: CALIBRATION COMPLETE

I/O MODULE TO POD

This procedure calculates the proper settings for the I/O Module's internal clock delay for use with the SYNC I/O MOD TO EXT and the SYNC I/O MOD TO POD commands. When either is entered, the appropriate delay is selected. This calibration procedure requires use of the Calibration Module. Perform the calibration as follows:

1. Connect the Pod to a UUT.
2. Press the MAIN MENU key, and use the left arrow key to move the cursor to the left-most field.

3. Press the CAL softkey.
4. Move the cursor to the next field, and press the I/O MOD softkey.
5. Move the cursor to the next field, and press the POD softkey.
6. Move the cursor to the next field, and press the desired softkey. For example, if you intend to use the 9100A/9105A in SYNC I/O MOD TO POD ADDR mode, press the ADDR softkey. In this case, the display should read:

MAIN: CAL I/O MOD TO POD ADDR

7. Press the ENTER key. This display should read:

MAIN: CAL I/O MOD TO POD ADDR
INSTALL CAL HEADER IN DESIRED I/O MODULE
PRESS BUTTON WHEN READY

8. Plug the Calibration Module into the I/O Module, and press the Calibration Module ready button. Make sure the calibration lead on the Calibration Module is unconnected when pressing the ready button.
9. After a few seconds, a pod dependent message is displayed. For example, the display may read:

COMPLETED EXT CAL PRIOR TO CAL POD
NOW CONNECT CAL LEAD TO ~S1
PRESS BUTTON WHEN READY

10. Refer to a schematic of the UUT and locate the specified signal. At a suitable point on the UUT, attach the calibration lead to this signal.
11. Press the Calibration Module ready button. After several seconds, the display should read:

MAIN: CALIBRATION COMPLETE

12. Repeat steps 6 through 11 for each SYNC mode in which the 9100A/9105A is to be operated.

SAVING AND RESTORING CALIBRATION DATA

Calibrating the 9100A/9105A at every power-up or reset is not necessary. A more convenient procedure is to restore calibration data from the user disk after the self tests have been performed and the system configured.

Each calibration generates data, which can be saved on the user disk using the SETUP MENU key. Once the system is calibrated for a given Pod, Probe, Clock Module, and I/O Module, the data is good until one or more of those devices is changed.

4/Maintenance

Invalid Calibration Data

The calibration data restored from the user disk may be invalid if any of the following conditions apply:

- o After the data was saved, one or more system components (Pod, Probe, I/O Module, Clock Module) were changed. This condition includes moving or exchanging I/O Modules, such as moving an I/O Module from connector 1 to connector 2.
- o The system has never been calibrated.
- o The system was last calibrated more than one month ago.

Saving Calibration Data

Save calibration data on the disk as follows:

1. Press the SETUP MENU key, and use the left arrow key to move the cursor to the left-most field.
2. Press the SAVE softkey.
3. Move the cursor to the next field, and press the CALDATA softkey.
4. Move the cursor to the next field, and press one of the following softkeys:

USERDISK This key is used if the user disk does not contain a UUT directory. The resulting display should read:

SAVE CALDATA IN USERDISK

UUT FILE This key is used if the user disk contains a directory for the UUT.

5. If you pressed the UUT FILE softkey in step 4, type the UUT directory name. For example, type DEMO. The display should read:

SAVE CALDATA IN UUT FILE DEMO

6. Press ENTER to save calibration data.

Restoring Calibration Data

Use the following procedure to restore calibration data from a user disk:

1. Press the SETUP MENU key, and use the left arrow key to move the cursor to the left-most field.
2. Press the RESTORE softkey.
3. Move the cursor to the next field, and press the CALDATA softkey.
4. Move the cursor to the next field, and press one of the following softkeys:

USERDISK Use this softkey if the calibration data was saved in the USERDISK directory. The resulting display should read:

RESTORE CALDATA FROM USERDISK

UUT FILE Use this softkey if the calibration data was saved in a UUT directory.

5. If you pressed the UUT FILE softkey in step 4, type the UUT directory name. For example, type DEMO. The display should read:

RESTORE CALDATA FROM UUT FILE DEMO

6. Press ENTER to restore the previously saved calibration data.

4/Maintenance

TROUBLESHOOTING

This manual does not contain troubleshooting procedures. Component level troubleshooting is supported by the 9100A Service Kit, P/N 818948. The Service Kit uses Guided Fault Isolation (GFI) programs to assist in troubleshooting 9100A/9105A systems. The Service Kit contains GFI and utility programs, an extender board, and instructions. To use the Service Kit, another 9105A or 9100A, an I/O Module (9100A-003), and a 9000A-68000 Interface Pod are required.

REPAIR

General Repairs

STATIC AWARENESS

Improper handling of components or assemblies may cause instantaneous or delayed electrostatic discharge damage. The yellow "Static Awareness" sheet inserted near the front of this manual explains some of the hazards associated with static electricity and sensitive components.

COMPONENTS

Several of the assemblies in the 9100A/9105A are built with surface mount components. See the following Surface Mount Repair information concerning mechanical design and repair of these components.

Surface Mount Repair

SURFACE MOUNT TECHNOLOGY

Surface Mount Technology (SMT) is a new component packaging and manufacturing technique that continues the trend towards miniaturization of electronic components. Although the "chip" inside the component package is the same as used with other techniques, the package is much smaller. The leads of an SMT component are soldered to the surface of a circuit assembly, rather than being inserted and soldered into holes in the circuit assembly.

Component Packages

Most common electronic components are available in Surface Mount Technology. The SMT component packages used in the 9100A are illustrated and described in the following paragraphs.

The Small Outline Integrated Circuit (SOIC) package is rectangular with gull wing shaped leads, spaced 0.05 inches on center. The SOIC comes in a narrow body package with 8 to 16 leads, and in a wide body package with 14 to 28 leads. See Figure 4-10.

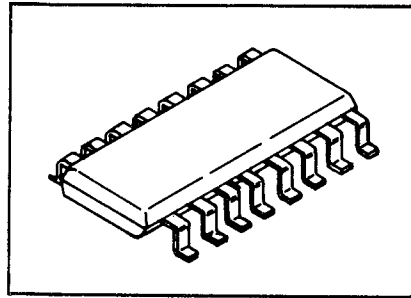

Figure 4-10. Small Outline Integrated Circuit (SOIC)

The Plastic Leaded Chip Carrier (PLCC) package is square or rectangular in shape, with 0.05 inch on-center leads located on all four sides. The leads are formed in a "J" shape, wrapping underneath the body. The PLCC is used for for large devices with 20 to 84 leads. See Figure 4-11.

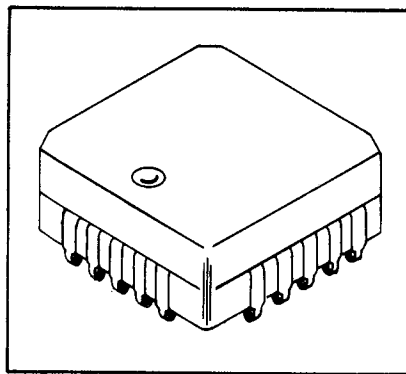

Figure 4-11. Plastic Leaded Chip Carrier (PLCC)

Not all ICs are available in surface mount packages. Therefore, some printed circuit assemblies use a mixture of DIP packages and SMT devices. A DIP packaged IC that has been modified for surface mounting (leads cut short) is called a butt-soldered dual inline package. See Figure 4-12.

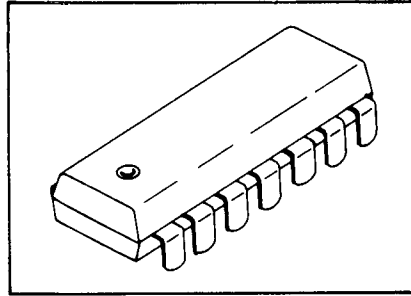

Figure 4-12. Butt-Soldered DIP

Transistors and diode pairs are packaged in several sizes of Small Outline Transistor (SOT) packages. The SOT-23 package, shown in Figure 4-13, is the most common package for small signal transistors; the leads are grouped with the collector on one side and the base and emitter leads on the opposite side.

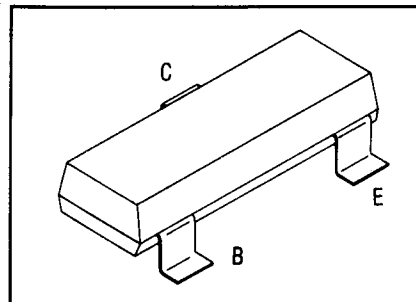

Figure 4-13. Small Outline Transistor (SOT)

Signal diodes, rectifiers, and zeners are packaged in a cylindrical Metal Electrode Face bonded (MELF) package. The stripe indicates the cathode end. See Figure 4-14.

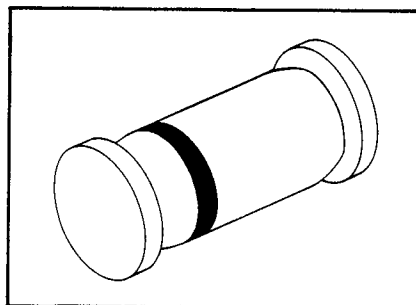

Figure 4-14. Metal Electrode Face (MELF)

Resistors and capacitors are packaged in rectangular ceramic leadless bodies, commonly called chips. See Figure 4-15.

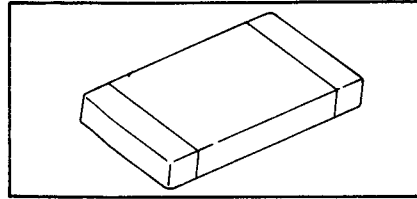

Figure 4-15. Chip Component

Printed Circuit Assembly Design

Surface Mount Technology impacts the way printed circuit assemblies are designed. Assembly layout is simplified because conductive traces do not have to be routed around protruding component leads. As a result, surface mount assemblies typically have fewer layers. The assembly layers are interconnected with plated through-holes called vias. The reduction of component lead spacing from 0.1 to 0.05 inches has shrunk traces and spacings to approximately half the previous size.

Fluke has developed a circuit pad "footprint" for surface mount components that aids both test and repair. This circuit layout uses staggered test pads and vias to make room for test probes. A probe can make contact with either a test pad or a via, avoiding the component lead and preventing an open solder connection from being temporarily closed and hidden by direct pressure on a component lead. Most signal paths do not appear on the outer surfaces of the assembly; vias connect the component pads to the signal paths on the inner layers. See Figure 4-16.

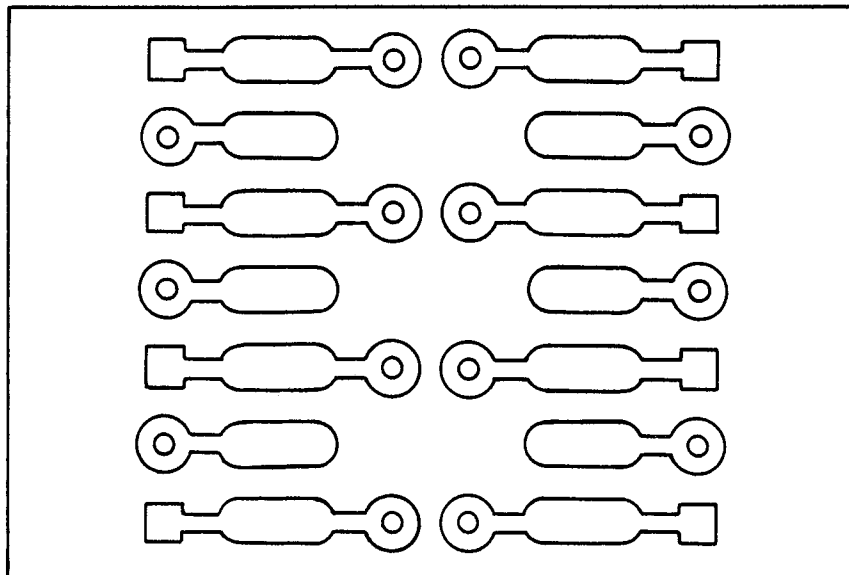

Figure 4-16. Surface Mount Footprint

4/Maintenance

SMT and Serviceability

SMT offers increased quality and reliability. When it becomes necessary, servicing can be accomplished quickly and reliably. Surface mount assemblies have a high component density, making replacement costly. However, the component level repair of these assemblies is not difficult and does not require involved training or large expense. Repair techniques for surface mount assemblies are described later in this section.

Troubleshooting SMT

Functionally, there is no difference between an IC in a DIP package and the same device in a surface mount package. Therefore, related troubleshooting techniques are very similar. Any differences in troubleshooting are related to size and mechanical construction.

When troubleshooting an SMT assembly, the circuit should be probed on the test pads or vias next to the component leads, rather than directly on the lead. This prevents disguised failures resulting from probe pressure on the lead closing a defective solder connection.

Special servicing precautions must be followed because of the reduced lead spacing on components and smaller printed circuit assembly pads and traces. Special care must be taken in the following areas:

- o Ordinary test probes can easily short two adjacent leads or pads.
- o Standard soldering irons and desoldering tools can damage the small pads of a SMT assembly.

Component Identification

Do not allow components to become mixed. Due to their size, chip components are often not marked. It is even difficult to distinguish a resistor from a capacitor. Use a clean work area, and keep the chip components in labeled packages. With limited space available, the assemblies seldom provide silk-screened reference designators for chip components. Technicians must rely on the circuit assembly layout drawings and parts lists for chip component locations and values.

Surface mount ICs are marked with the device number, but their leads are indexed differently from those on DIP packages. On the PLCC package, pin number one is indicated by a dimple in the plastic called an index dot. See Figure 4-17.

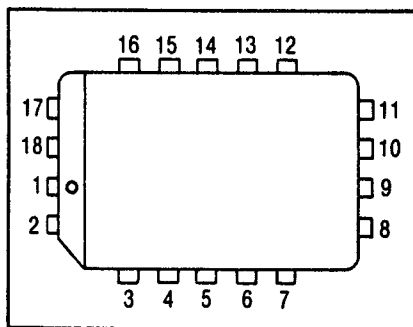

Figure 4-17. PLCC Lead Index

Pin number one on the SOIC package is located on the far left of the beveled side. SOIC packages do not have a notch or dimple to indicate pin one. See Figure 4-18.

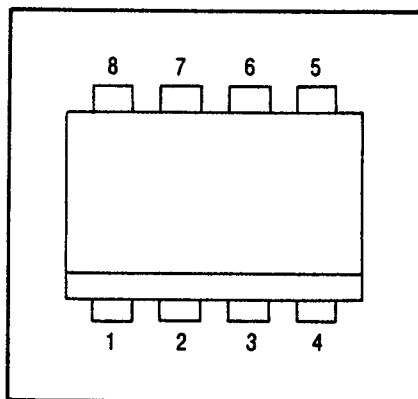

Figure 4-18. SOIC Lead Index

REPAIR TECHNIQUES

Although surface mount assemblies are repaired with somewhat different tools and techniques than through-hole printed circuit assemblies, the techniques and tools required are not complicated. In fact, a surface-mounted IC can be removed and replaced much faster and easier than a DIP package. Surface mount repair is simpler in that no through-hole solder must be removed.

Solder flux is used chemically to clean both the component lead and the solder. The flux removes oxides from the metals and acts as a wetting agent. With SMT, only enough solder to make a positive metallic contact is necessary; too much solder can cause bridging. Also, solder provides the only mechanical fastening for SMT; too little solder can cause weak or open solder joints.

Rework of SMT assemblies is often performed under a five-inch illuminated magnifier lamp. The lamp is used when applying the solder, positioning the component, or inspecting the finished rework.

Hot air from a heat gun is used to reflow the solder. This technique, called convection reflow, requires careful application of controlled heat. Excess heat can damage components, other solder joints, and the board. To prevent components from being overheated, temperature sensitive paint is applied to the top of the component. The paint liquefies when the proper reflow temperature of the solder has been reached. An adapter or reducing nozzle is used on the heat gun to direct heat to a specific component without disturbing adjacent components.

CAUTION

The fine, closely-spaced traces and pads that are used in SMT are fragile and easily separated from the surface mount assembly. Care must be taken when removing a component. Make sure the solder has reflowed on all the pins before removing the component. Wait until the temperature sensitive paint liquefies and changes color, then remove the component. Attempting component removal before the solder has melted can result in separation of the pad and possibly the trace.

Removal of Integrated Circuits

Use the following procedure to remove surface mounted ICs:

1. Apply a drop of temperature sensitive paint to the top of the IC. The paint dries quickly.
2. Use the heat gun with adapter or nozzle to heat the component, taking care to aim the hot air only at the leads. The paint turns to a clear liquid when the component reaches 400 °F, the reflow temperature of the solder.
3. When the solder has reflowed, carefully lift the component off the board. Attempting to move the component before the solder has melted can damage the circuit assembly.

Removal of Chip Components and Transistors

Chip components and transistors can be removed as outlined above. Since it is easier to see the solder reflow on two- and three- terminal components, paint application is not necessary. However, in some cases it is easier to use a low wattage soldering iron with slot tip adapters instead of the heat gun. For component removal with the iron, apply the slotted tip so that the tinned surface touches the solder fillet between the component lead and the assembly pads. Do not press on the assembly while heating. Contact the assembly gently and let the heat of the tip do the work. As soon as the solder melts completely, remove the component from the assembly with a slight twisting action of the iron tip. The component adheres to the wetted surface of the tip through capillary action.

4/Maintenance

Installing Integrated Circuits

Use the following procedure to install surface mounted ICs:

1. Once the defective component has been removed, prepare the assembly for the replacement component.
 - a. If sufficient solder remains on the pads, brush them with liquid flux, and continue to the next step.
 - b. If sufficient solder does not remain on the pads, add solder to the pads with small diameter solder, using a low wattage or temperature-controlled soldering iron. If the amount of solder on the pads is not even, gently brush a wide tip soldering iron across the pads. This technique removes solder from pads that have an excess and adds solder to pads that have less. To prevent damage to the board, perform all work quickly using a light iron pressure and no rubbing.
2. Apply a drop of temperature sensitive paint to the top of the IC.
3. Place and align the component on the pads. Perfect alignment is not necessary. Once the leads are partially placed on the correct pads, the molten solder pulls then onto the center of the pad.
4. Use the gun to heat the component, taking care to aim the hot air only at the leads. The paint becomes liquid when the component reaches the reflow temperature of the solder.
5. Once the component has reached the reflow temperature, remove the heat. If the component is not aligned perfectly on the pads, tap the board very gently while the solder is still molten. This procedure allows the surface tension of the solder to pull the component leads on to the pad centers. Allow the assembly to cool. Clean and inspect the solder joints as outlined in the following paragraphs.

Cleaning

The flux residue must be washed off immediately after repair. The longer the flux remains, the harder it is to clean. Flux residue also makes inspection and future repairs very difficult and can cause shorts. An aerosol freon spray flux remover/cleaner is sufficient to clean the reworked area.

Inspection of Rework

SMT miniaturization allows for closely spaced solder joints that must be carefully inspected for defects. A lighted magnifying glass is required to inspect the working area adequately.

A good solder joint exhibits the following qualities:

- o Absence of excess solder. The shape of the lead is clearly outlined in the joint.
- o The joint is completely covered with solder.
- o Filled areas have a concave contour.
- o Edges are feathered.

Inspect each component for the following characteristics:

- o On a chip component the solder should wick three quarters across the face and two thirds up the side of the contact surface. See Figure 4-19.

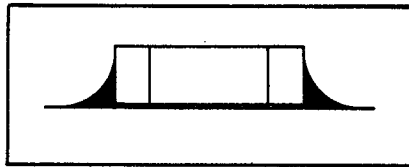

Figure 4-19. Chip Soldering

- o On a PLCC device the solder should fill both outside rounded areas of the "J" lead with a smooth, concave contour. See Figure 4-20.

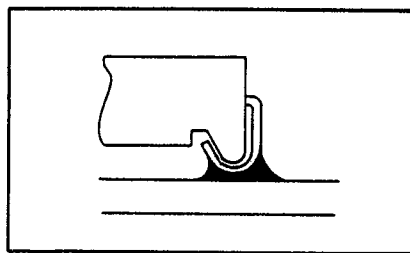

Figure 4-20. PLCC Soldering

- o On an SOIC or flatpack device the solder joint should extend the full length of the portion of the lead that makes contact with the pad. The lead outline should be clearly visible under the solder. See Figure 4-21.

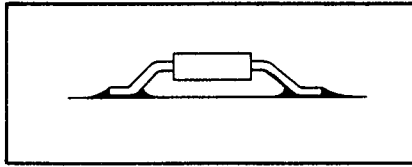

Figure 4-21. SOIC Soldering

Inspect each solder joint for the following defects:

- o Solder balls. The solder should reflow into a single mass on the pad. However, some smaller solder spheres may not combine with the main sphere of solder. Remove solder balls by cleaning the solder connections with a small brush.
- o Solder bridges. Solder may bridge two adjacent pads if applied in excess. A solder bridge may be removed with a soldering iron.
- o Missing solder. If the solder joints are weak or incomplete, the component must be removed and resoldered correctly.
- o Cold joints. Cold solder joints have a frosted, gritty appearance. They are caused by insufficient heat or by moving the component before the solder has cooled. A component with cold solder joints must be removed and resoldered correctly.
- o Lifted pads. Pads that separate from the board cannot be repaired, and the board must be scrapped. The best way to prevent board damage is to avoid excessive heat and allow the solder to reflow completely before removing components.
- o Flux residues. Any flux residues remaining on the board after cleaning must be removed with further cleaning.

TOOLS AND SUPPLIES

The tools and supplies mentioned in Table 4-6 have been carefully selected for efficient and reliable rework. Substitutions of the heat gun must be made with care. The correct solder and proper application of heat are critical for reliable repair of SMT assemblies.

Table 4-6. SMT Rework Tools and Supplies

DESCRIPTION	MODEL NUMBER
Hot air rework station, solder nozzle adapters	Leister Labor "S", Model 7A #31D6, for 14- and 16-pin SOICs #31D5, for 28-, 44-, and 68-pin PLCCs
- or -	
Heat gun with reducing baffle 750°F nozzle temperature	Ungar heat gun, Model 6966C Reducing baffle, Model 6958
Soldering iron, 15W	Soldermaster Model SMD10
Soldering iron tips for chip components and transistors	Soldermaster number S102 and S203
Solder, Multicore	Xersin 2055 Fluke P/N 715565
Temperature indicating paint 400°F/204°C	Omega Omegalaq, 2 oz bottle
T.M.C. Cleaner (rosin flux remover)	Sprayon Number 2009
Flux	Xersin 2005 Fluke P/N 715573

4/Maintenance

Repair Information

GENERAL

Many of the assemblies in the 9100A/9105A use Surface Mount Technology (SMT). The repair techniques for these printed circuit assemblies (PCAs) are different than those used for the older-style printed circuit boards that use throughhole mounted components. For more information on SMT, see the Surface Mount Repair information in this manual.

Some of the assemblies in the 9100A/9105A are Original Equipment Manufacturer (OEM) modules; each of these modules is treated as a single part. This Service Manual does not contain component level parts lists for these modules, since they are not manufactured or supported to the component level by Fluke.

MAIN PCA

The Main PCA almost exclusively uses surface mount technology. Many of the other assemblies in the 9100A/9105A mainframe connect directly to the Main PCA. These assemblies include the Power Supply, Floppy Disk Drive(s), RAM Modules, Display PCA, Probe I/O PCA, Multi-Function Interface PCA, and Video Controller PCA. The fan and serial Ports 1 and 2 plug into the Main PCA. Also, an Interface Pod and the Programmer's Keyboard plug into external connectors on the Main PCA.

The Main PCA includes an EEPROM, U11, that contains characterizing data for the instrument and stores certain parameters. If this EEPROM is to be replaced, the replacement must be ordered as a programmed part. Certain characteristics must be programmed into it after the replacement EEPROM is installed; this can be done by a Fluke Technical Center, or with a utility program that is included with the 9100A Service Kit. Also, certain other hardware changes require that the EEPROM be reprogrammed.

CAUTION

When reinstalling the Main PCA (or rear panel) take care to connect the cables from the RS-232 ports to the correct connectors on the pca. Improper connections can cause a short to earth ground. Proper connections are: RS-232 Port 1 to J3 on the Main PCA and RS-232 Port 2 to J2 on the Main PCA.

DISPLAY AND KEYPAD

The Display PCA uses surface mount technology. The Keypad PCA connects to the Display PCA.

Display and Keypad PCAs have several built in self tests and diagnostics; these are described under "Display Self Test" earlier in this section. The self tests allow checking and some troubleshooting of the display and operator keypad functions.

The Display PCA contains a vacuum fluorescent display tube. This display tube has a glass envelope and is susceptible to breakage. Caution should be taken to prevent sharp blows or direct pressure to the glass envelope or to leads of the vacuum fluorescent tube.

The display tube is driven with high voltage (approximately 70 volt pulses at the grids and anodes). Attempting to measure the outputs of the driving circuitry or the inputs to the display tube with a logic probe or other low voltage measuring device can cause equipment damage.

The Keypad PCA's only active components are the key switches and a single light-emitting diode.

PROBE I/O

The Probe I/O PCA uses surface mount technology extensively. It includes several custom LSI components. The I/O Connector PCA and Trigger Output connector plug into this assembly. The Clock Module, Single-Point Probe, and the External Switch plug into external connectors. The Probe fuse holder is also mounted on the Probe I/O PCA.

The Probe I/O PCA contains the logic probe signal input circuitry. Changes to portions of this circuitry cause calibration changes. Probe compensation should be performed after any changes in the probe input circuit, including replacing or changing the Single-Point Probe. Any changes in the probe threshold or DAC (digital to analog) circuits require reprogramming the probe offset level in the EEPROM (U11 on the Main PCA); this can be done by a Fluke Technical Center, or with a utility program that is included with the 9100A Service Kit.

I/O CONNECTOR

There is no special repair information for the I/O Connector PCA.

SINGLE-POINT PROBE

The Single-Point Probe primarily uses surface mount technology. Repair or replacement of the probe, or use of another probe, requires that the probe compensation adjustment be performed.

CLOCK MODULE

The Clock Module is partially based on surface mount technology.

When reinstalling the Clock Module case or flying lead wires, take care to install them correctly. The case should be installed with the signal name "COMMON" next to the black lead wire; the flying lead wires should be installed with the black lead wire on the same side of the assembly as the fuse holder. Remember to install the plug in the case hole (opposite the fuse holder).

4/Maintenance

The operating software can be loaded on a formatted hard disk even if the 9100A is not able to boot up from the hard disk. Use the following procedure:

1. Put the System Disk 1 floppy disk in the floppy disk drive.
2. Hold down the "SOFT KEYS", "F2", and "F4", and turn on the 9100A power (or press the Restart button on the right side panel if the power is already on).
3. When the display message indicates that it is booting from the floppy disk, release the three keys.
4. Change to System Disk 2 when instructed by the display.
5. When the 9100A displays the READY message, the software can be loaded on the hard disk by using the COPY function in the Main Menu to copy the System and User disks (and Programmer's software, if applicable) from the floppy disks to the hard disk. See Section 3 of the Technical User's manual for more information on copying disks.

MULTI-FUNCTION INTERFACE

The Multi-Function Interface PCA is standard only in the 9100A. This assembly plugs into J6 on the Main PCA (the 96-pin connector on the right). The Hard Disk Controller is connected through a cable to a connector on the Multi-Function Interface; the assembly also contains the Real-Time Clock circuit. The Multi-Function Interface PCA may have several empty component spaces on the board that have been reserved for special features.

The 9105A Real-Time Clock option uses a version of the Multi-Function Interface PCA with only clock circuitry installed.

VIDEO CONTROLLER

The Video Controller PCA uses mainly surface mount technology. The Monochrome Video Interface and the Color Video Interface use the same assembly, with jumpers to select the mode. The Video Controller plugs into J5 on the Main PCA (the 64 pin connector between J4 and J6); it has an external connector that passes through the rear panel for connection to a monitor.

For the Monochrome video interface, jumper block Z1 is installed on the Video Controller PCA; jumper block Z2 is installed for the Color video interface.

MONOCHROME MONITOR

The Monochrome Monitor contains two OEM modules. The power supply is an OEM module that is replaced as a single part. The crt and Video Display Electronics PCA is an OEM set; both the crt and Video Display PCA are replaced at the same time.

I/O MODULE

The I/O Module consists of two assemblies. The I/O Main PCA uses surface mount technology, with components mounted on both sides of the board. The I/O Module Top PCA has interface connectors and a few other components.

Repair of the I/O Main PCA, which has SMT components mounted on both sides, is performed in the same way as with other SMT assemblies, except that extra care needs to be taken not to overheat the board. Too much heat applied to one side could cause nearby components on the other side to pull away from the pads or fall off the board.

Replacing the external mating connectors on the I/O Module Top PCA must be done carefully. The connectors are a high-reliability type, designed for a large number of insertion/removal cycles. Alignment of the connectors is critical to allow proper mating with the external interface modules. When replacing the connectors, align them in the same way as the mating connectors on the Clip or Flying Lead modules, below, using a full width interface module as an alignment fixture.

CLIP OR FLYING LEAD MODULES

The Clip and Flying Lead Modules interface the I/O modules to a Unit Under Test (UUT) using IC clips or flying leads. They are either half width modules, for up to 24 pins, or full width modules, for up to 40 pins. The Calibration Module (used for software calibration of the I/O Module) is similar to the full width modules.

The Clip and Flying Lead modules use internal configuration switches that are read by the I/O Module to determine the type of module attached. The half-width modules use a four-bit switch, and the full-width modules use an eight-bit switch. See Table 4-9 for a list of switch settings. When servicing a clip or flying lead module, be sure that the configuration switches are set correctly.

Table 4-9. Clip and Flying Lead Module Configuration Switch Settings

4-BIT SWITCH 4321	MODULE	
0000	14-Pin Clip	
0001	16-Pin Clip	
0010	18-Pin Clip	
0011	20-Pin Clip	
0100	24-Pin Clip	
1101	20-Pin Flying Lead Set	
		0 = on (closed)
		1 = off (open)
8-BIT SWITCH 8765 4321	MODULE	
1110 0000	28-Pin Clip	
1110 0001	40-Pin Clip	
1110 0010	Calibration Module (hardwired)	

The connectors and connector alignment posts that mate the Clip or Flying Lead modules to the I/O Module must be aligned precisely with the mating connectors on the I/O Module. Use the following procedure when installing the connectors:

1. Make sure the solder is removed from all the holes for the connector before attempting to install it. The connector should fit loosely in the holes.
2. Place the connector in the holes in the board, and place the connector posts through the large holes in either end. Be sure that the notches on the posts line up correctly.
3. Put on the nuts or screws loosely enough that the connector can move somewhat. Use an I/O Module as an alignment fixture; gently plug the module being repaired into an I/O Module, taking care that the connectors mate correctly. With the connectors completely seated, tighten the nuts or screws, and solder several pins on the connector (and the alignment posts, if necessary) to hold it in place. The module being repaired can be unplugged to solder the remaining pins.

Section 5
List of Replaceable Parts

TABLE OF CONTENTS

ASSEMBLY NAME	DRAWING NO.	TABLE		FIGURE	
		NO.	PAGE	NO.	PAGE
Model Configurations		5-1	5-5		
9100 Series Final Assembly	9100A	5-2	5-6	5-1	5-8
A1 Main PCA	9100A-4001	5-3	5-17	5-2	5-19
A2 Display Interface PCA	9100A-4002	5-4	5-20	5-3	5-21
A4 Video Controller PCA	9100A-4004	5-5	5-22	5-4	5-23
A5 Probe Assembly	9100A-4005	5-6	5-24	5-5	5-25
A6 Clock Module PCA	9100A-4006	5-7	5-26	5-6	5-27
A7 I/O Module (Main) PCA	9100A-4007	5-8	5-28	5-7	5-29
A8 I/O Module (Top) PCA	9100A-4008	5-9	5-30	5-8	5-31
A9 Probe I/O Interface PCA	9100A-4009	5-10	5-32	5-9	5-34
A10 Multi-Function I/F PCA	9100A-4010	5-11	5-35	5-10	5-36
A11 I/O Connector PCA	9100A-4011	5-12	5-37	5-11	5-38
A12 Half-Width Clip Modules	9100A-4012	5-13	5-39	-	
A13 Full-Width Clip Modules	9100A-4013	5-14	5-40	-	
A14 Calibration Module	9100A-4014	5-15	5-41	-	
A15 Flying Lead Module	9100A-4012	5-16	5-42	-	
A16 512K RAM Module	9100A-4016	5-17	5-43	5-12	5-44
A19 Monochrome Monitor		5-18	5-45	-	
-003 Parallel I/O Module	9100A-003	5-19	5-46	5-13	5-47
-004 Programmer's Station, Mono	9100A-004	5-20	5-50	5-14	5-51
-005 Programmer's Station, Color	9100A-005	5-21	5-53	5-15	5-54
-008 Real-Time Clock PCA	9105A-4017	5-22	5-56	5-16	5-57
-009 Video, Monochrome	9100A-009	5-23	5-58	5-17	5-59
-011 Video, Color	9100A-011	5-24	5-61	5-18	5-62
-013 Programmer's Keyboard	9100A-013	5-25	5-63	-	

INTRODUCTION

Section 5 provides an illustrated parts list for the 9100A, 9105A, and related optional assemblies.

Components are listed alphanumerically by assembly. Both electrical and mechanical components are listed by reference designation. Each listed part is shown in an accompanying illustration.

The parts lists contain the following information:

- o Reference Designator
- o Description
- o Fluke Stock Number
- o Federal Supply Code for Manufacturers (MFRS SPLY CODE)
- o Manufacturer's Part Number
- o Total Quantity of Components per Assembly (TOT QTY)
- o Recommended Spare Quantity (RSQ)

The number in the RSQ column represents the number of spare parts necessary to support one to five instruments for a period of 2 years. This quantity assumes that common electronic parts are available at the maintenance site. To maintain the instrument for 1 year or more at an isolated site, it is recommended that at least one of each assembly in the instrument be stocked. In the case of optional subassemblies, plug-ins, etc., that are not always part of the instrument or are deviations from the basic instrument model, the RSQ column lists the recommended spare quantity for the items in that particular assembly.

5/List of Replaceable Parts

HOW TO OBTAIN PARTS

Components may be ordered directly from the manufacturer's part number, or from the John Fluke Manufacturing Co., Inc. or an authorized representative by using the Fluke Stock Number. In the event the part ordered has been replaced by a new or improved part, the replacement will be accompanied by an explanatory note and installation instructions if necessary.

To ensure prompt and efficient handling of your order, please include the following information:

- o Quantity
- o Fluke Stock Number
- o Description
- o Reference Designation
- o Printed circuit assembly (PCA) number and revision letter
- o Instrument Model Number and Serial Number

Parts price information is available from the John Fluke Manufacturing Co., Inc. or its representative. Prices are also found in the Fluke Replacement Parts Catalog, which is available on request.

CAUTION

An asterisk in the "S" (static) column indicates a device or component subject to damage by static discharge.

Table 5-1 identifies the parts lists applicable to your 9100 Series model. For example, for the 9100A Digital Test System, Tables 5-2, 5-3, 5-4, 5-6, 5-7, 5-10, 5-11, 5-12, and 5-17 would be used.

Table 5-1. Model Configurations

		9100A/SYS Digital Test Programming Station							
		9100A Digital Test System							
		9100A-003 Parallel I/O Module							
		9100A-004 Programmer's Station, Mono							
		9100A-005 Programmer's Station, Color (Table 5-21)							
		9100A-009 Video, Monochrome (Table 5-23)							
		9100A-011 Video, Color (Table 5-24)							
		9105A Digital Test Station							
RELATED PARTS LISTS:									
Table	Assembly/Option	↓	↓	↓	↓	↓	↓	↓	↓
5-2	Final Assembly	X						X	X
5-3	A1 Main PCA	X						X	X
5-4	A2 Display Interface PCA	X						X	X
5-5	A4 Video Controller PCA		X	X	X	X			X
5-6	A5 Probe PCA	X						X	X
5-7	A6 Clock Module PCA	X						X	X
5-8	A7 I/O Module (Main) PCA						X		X
5-9	A8 I/O Module (Top) PCA						X		X
5-10	A9 Probe I/O PCA	X						X	X
5-11	A10 Multi-Function I/F PCA							X	X
5-12	A11 I/O Connector PCA	X						X	X
5-13	A12 Half-Width Clip Module								X
5-14	A13 Full-Width Clip Module								X
5-15	A14 Calibration Module						X		X
5-16	A15 Flying Lead Module						X		X
5-17	A16 512K RAM Module*	X						X	X
5-18	A19 Monochrome Monitor			X		X			X
5-19	-003 Parallel I/O Module								X
5-20	-004 Programmer's Station, Mono								X
5-22	-008 Real-Time Clock PCA (optional)	X							
5-25	-013 Programmer's Keyboard				X	X			X

* -007 512K Memory Expansion is included in Table 5-17.

5/List of Replaceable Parts

Table 5-2. 9100 Series Final Assembly
(See Figure 5-1.)

REFERENCE DESIGNATOR	FLUKE STOCK	MFRS SPLY	MANUFACTURERS PART NUMBER	TOT QTY	R S T	N O
-A>-NUMERICS-->	---NO---	-CODE-	-OR GENERIC TYPE----	QTY-	-Q-	-E-
S-----	-----	-----	-----	-----	-----	-----
DESCRIPTION						
A 1	* MAIN PCA	768754	89536 768754	1		
A 2	* DISPLAY INTERFACE PCA	768689	89536 768689	1		
A 3	KEYPAD ASSEMBLY	846357	89536 846357	1		
A 5	* PROBE ASSEMBLY	773911	89536 773911	1		
A 6	* CLOCK MODULE ASSEMBLY	768812	89536 768812	1		
A 9	* PROBE I/O INTERFACE PCA	768796	89536 768796	1		
A 10	* MULTI-FUNCTION INTERFACE PCA	767988	89536 767988	1		1
A 11	* I/O CONNECTOR PCA	767996	89536 767996	1		
A 16	* 512K RAM MODULE	822858	89536 822858	4		3
A 101	PWR SUP, 150W, +5V, (2)+12V, -5V	772988	89536 772988	1		
A 102	* DISK DRIVE, FLOPPY, 3.5"	829671	89536 829671	1		2
A 104	* DISK DRIVE, HARD, 3.5", FRMTD, 20MBYTS	834234	89536 834234	1		1
A 105	* WINCHESTER HARD DISK CONTROLLER	780940	89536 780940	1		1
CR 1	* LED, RED, PCB MNT, LUM INT=0.5MCD	369777	28480 5082-4480	1	1	
E 1	TERM, FASTON, REC, 18-22AWG, CRIMP, INSUL	655001	59730 RAD20377	1		
F 1	FUSE, 1/4 X 1-1/4, SLOW, 2A, 250V	109181	71400 MDX2	1		5
F 1	FUSE, 5X20MM, SLOW, 1A, 250V	808055	89536 808055	1		5
H 1	SPACER, HEX, ALUM, 4-40X0.500	192872	89536 192872	1		
H 2	SCREW, MACH, PHP SEMS, STL, 4-40X1/4	185918	89536 185918	2		
H 3	SCREW, MACH, PHP, STL, 4-40X1/2	558825	89536 558825	4		
H 4	SCREW, MACH, PH, P, STL, 6-32X0.250	152140	89536 152140	1		
H 5	NUT, WELD TAB, FLOATING, STEEL, 10-32	743393	89536 743393	2		
H 6	SCREW, MACH, PH, P, STL, 6-32X0.250	152140	89536 152140	5		
H 7	SCREW, MACH, PH, P, STL, 10-32X0.750	114306	89536 114306	2		
H 8	SCREW, MACH, PH, P, STL, 6-32X0.250	152140	89536 152140	14		
H 9	SCREW, MACH, PH, P, STL, 8-32X0.375	114124	89536 114124	2		
H 10	CONN ACC, D-SUB, LATCH BLOCK, SHORT, SLOT	811653	89536 811653	12		
H 11	SCREW, MACH, PH, P, STL, 4-40X3/8	129916	89536 129916	12		
H 12	CONN ACC, D-SUB, SLIDING LOCK, POST ASSY	353201	89536 353201	2		
H 13	CONN ACC, D-SUB, JACK SCREW, 4-40	448092	89536 448092	4		
H 14	SCREW, MACH, PH, P, STL, 6-32X0.250	152140	89536 152140	4		
H 15	RIVET, PUSH, UNIV, NYL, .16, .32	799957	89536 799957	4		
H 16	SCREW, MACH, PH, P, STL, 6-32X0.375	152165	89536 152165	2		
H 17	NUT, CAP EXT LW, STL, 6-32X7/64	152819	89536 152819	1		
H 18	DUST FILTER, SET	773994	89536 773994	1		
H 19	WASHER, SHLDR, NYLON, .320X.141X.065	733345	89536 733345	4		
H 20	RIVET, POP, DOME, AL, 0.125X0.440	800763	89536 800763	4		
H 21	FASTENER, STUD REC, TUBLR, 0.187 X 0.46	783134	89536 783134	2		
H 22	SCREW, MACH, PH, P, STL, 6-32X0.250	152140	89536 152140	8		
H 23	SCREW, MACH, PH, P, STL, 8-32X0.375	114124	89536 114124	4		
H 24	SCREW, MACH, SEMS, PH, P, STL, 6-32X0.375	177022	89536 177022	4		
H 25	SCREW, MACH, PHS, M3 X 12	799502	89536 799502	4		
H 26	SCREW, MACH, PH, P, STL, 6-32X0.500	152173	89536 152173	4		
H 27	SCREW, MACH, PH, P, STL, 6-32X0.250	152140	89536 152140	2		
H 28	SCREW, MACH, PH, P, STL, 6-32X0.250	152140	89536 152140	3		
H 29	SCREW, SHOULDER	775999	89536 775999	2		
H 30	CONN ACC, D-SUB, DUST CAP, 37 SCKT	615138	89536 615138	4		
H 31	CONN ACC, D-SUB, DUST CAP, 25 PIN	816371	89536 816371	2		
H 32	SCREW, MACH, PH, P, STL, 4-40X0.250	129890	73734 19022	1		
J 1	CONN, COAX, BNC (F), PANEL	152033	95712 30355-1	1		
MP 1	BOX, MAILER, CONVOLUTED FOAM INSIDE	707851	89536 707851	2		
MP 2	DISPLAY WINDOW, SHIELD	784009	89536 784009	1		
MP 3	9100A ACCESSORIES	788554	89536 788554	1	1	
MP 5	SHIELD, CLOCK MODULE	755793	89536 755793	1		
MP 6	CASE, CLOCK MODULE	755827	89536 755827	1		
MP 7	COVER	755686	89536 755686	1		
MP 8	CASE, CLOCK MODULE	755652	89536 755652	1		
MP 10	KEYPAD CASE TOP	765008	89536 765008	1		
MP 11	KEYTOP, SET	775858	89536 775858	1		
MP 12	KEYPAD, ELASTOMERIC	764910	89536 764910	1	1	
MP 13	CORD, LINE, 5-15/IEC, 3-18AWG, SVT	343723	89536 343723	1		
MP 14	TORSION SPRING	784025	89536 784025	2	1	
MP 15	KEYPAD CASE BOTTOM	765016	89536 765016	1		
MP 16	SPRING DETENT	765032	89536 765032	2		
MP 17	NAMEPLATE	787275	89536 787275	1		
MP 18	FRONT PANEL, PAINTED	764894	89536 764894	1		
MP 19	LENS	783993	89536 783993	1		4
MP 20	KEYPAD OPENING SHIELD	767889	89536 767889	1		
MP 21	HINGE/DETENT HOUSING	765024	89536 765024	2		
MP 22	MAINFRAME BASE	767848	89536 767848	1		

An * in 'S' column indicates a static-sensitive part.

5/List of Replaceable Parts

Table 5-2. 9100 Series Final Assembly (cont.)

REFERENCE DESIGNATOR	FLUKE STOCK	MFRS SPLY	MANUFACTURERS PART NUMBER	TOT	N R O S T
-A>-NUMERIC-----> S-----DESCRIPTION-----	--NO--	-CODE-	-OR GENERIC TYPE-----	QTY-	-Q -E-
MP 24	803221	89536	803221	1	
MP 25	801001	89536	801001	4	
MP 26	767855	89536	767855	1	
MP 27	460238	61935	031.1666	1	
MP 29	768010	89536	768010	1	
MP 30	768655	89536	768655	1	
MP 31	461020	89536	461020	1	
MP 32	565036	89536	565036	1	
MP 33	172080	89536	172080	1	
MP 34	226365	89536	226365	4	
MP 35	773986	89536	773986	1	
MP 36	768028	89536	768028	1	5
MP 37	787846	89536	787846	1	6
MP 38	830398	89536	830398	1	
MP 39	565036	89536	565036	1	
MP 40	381533	06383	PLT1M	1	
MP 41	802033	89536	802033	1	7
MP 42	782623	89536	782623	8	
MP 43	782631	89536	782631	8	
MP 44	806703	89536	806703	2	1
MP 45	472795	89536	472795	1	
MP 46	809103	89536	809103	1	
MP 47	819680	89536	819680	1	10
MP 48	757229	89536	757229	1	
MP 49	809038	89536	809038	1	
MP 50	809046	89536	809046	1	
MP 51	809053	89536	809053	1	
MP 52	809129	89536	809129	1	
SW 1	799551	89536	799551	1	1
SW 2	800649	89536	800649	1	1
TM 1	787960	89536	787960	1	
TM 2	809228	89536	809228	1	
TM 3	813832	89536	813832	1	
TM 4	813840	89536	813840	1	
TM 5	822866	89536	822866	1	
W 3	749903	89536	749903	1	
W 4	773267	89536	773267	1	
W 5	773424	89536	773424	1	
W 6	773432	89536	773432	2	
W 7	773846	89536	773846	1	8
W 8	773853	89536	773853	1	
W 9	773861	89536	773861	1	
W 10	773887	89536	773887	1	
W 11	783969	89536	783969	1	
W 12	787838	89536	787838	2	
W 13	787895	89536	787895	1	1
W 15	788448	89536	788448	1	1
W 16	788455	89536	788455	1	1
W 17	788471	89536	788471	1	
W 18	801944	89536	801944	1	
W 19	809178	89536	809178	1	
W 21	788430	89536	788430	1	9
XF 1	460329	89536	460329	1	

An * in 'S' column indicates a static-sensitive part.

NOTES:

- 1 = Not used on 9105A.
- 2 = For 9105A, quantity is 2.
- 3 = For 9105A S/Ns prior to 4352000, two 512K + two 256K (799833) were used.
- 4 = For 9105A, order p/n 805721.
- 5 = For 9105A, order p/n 805713, quantity 2.
- 6 = For 9105A, order p/n 787853.
- 7 = For 9105A, order p/n 788521.
- 8 = For 9105A, order p/n 788547.
- 9 = For 9105A, order p/n 805705.
- 10 = For 9105A, order p/n 802009.

A101 through A105 are Original Equipment Manufacturer (OEM) assemblies.
List of replaceable parts is not available.

5/List of Replaceable Parts

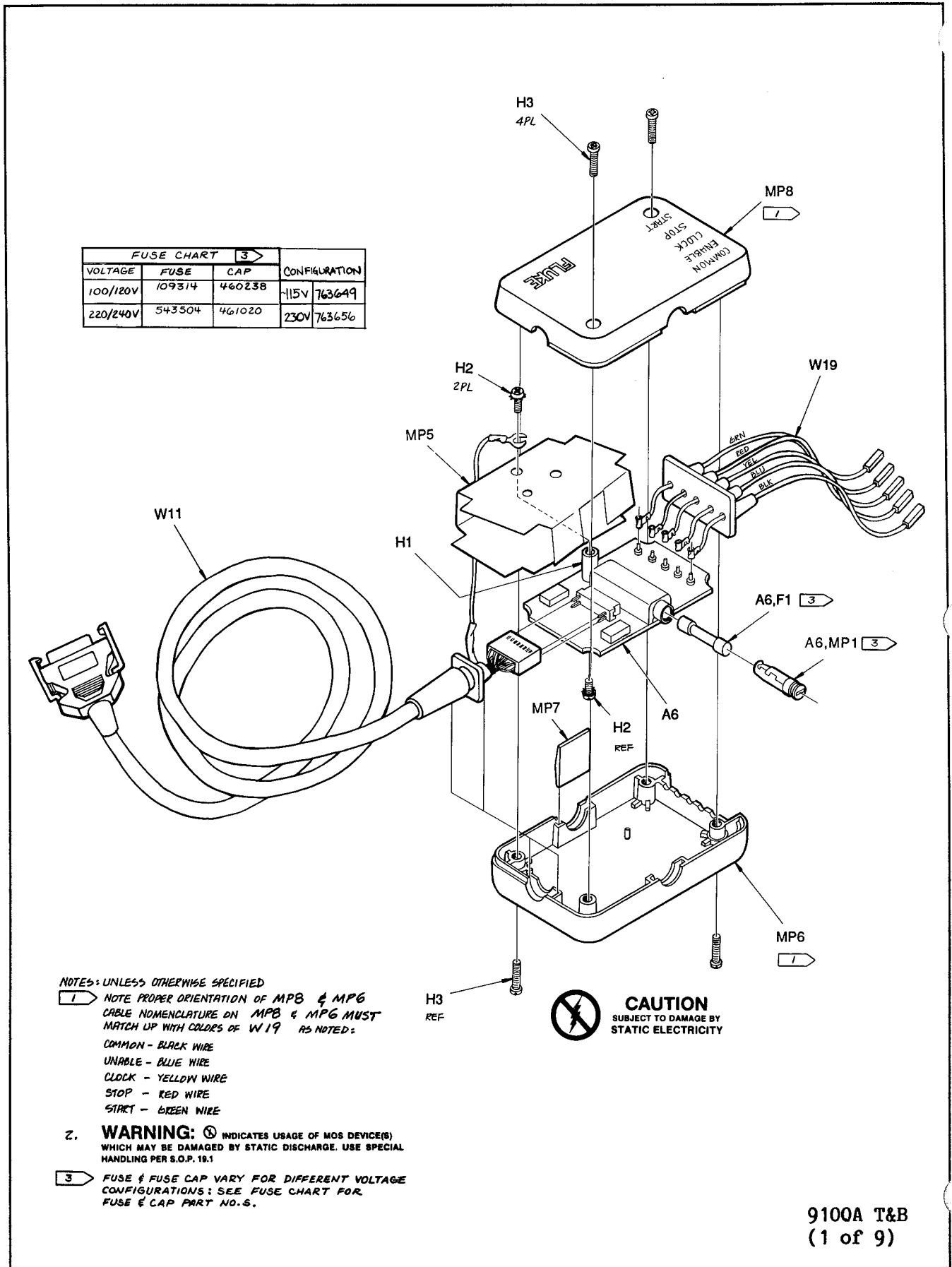
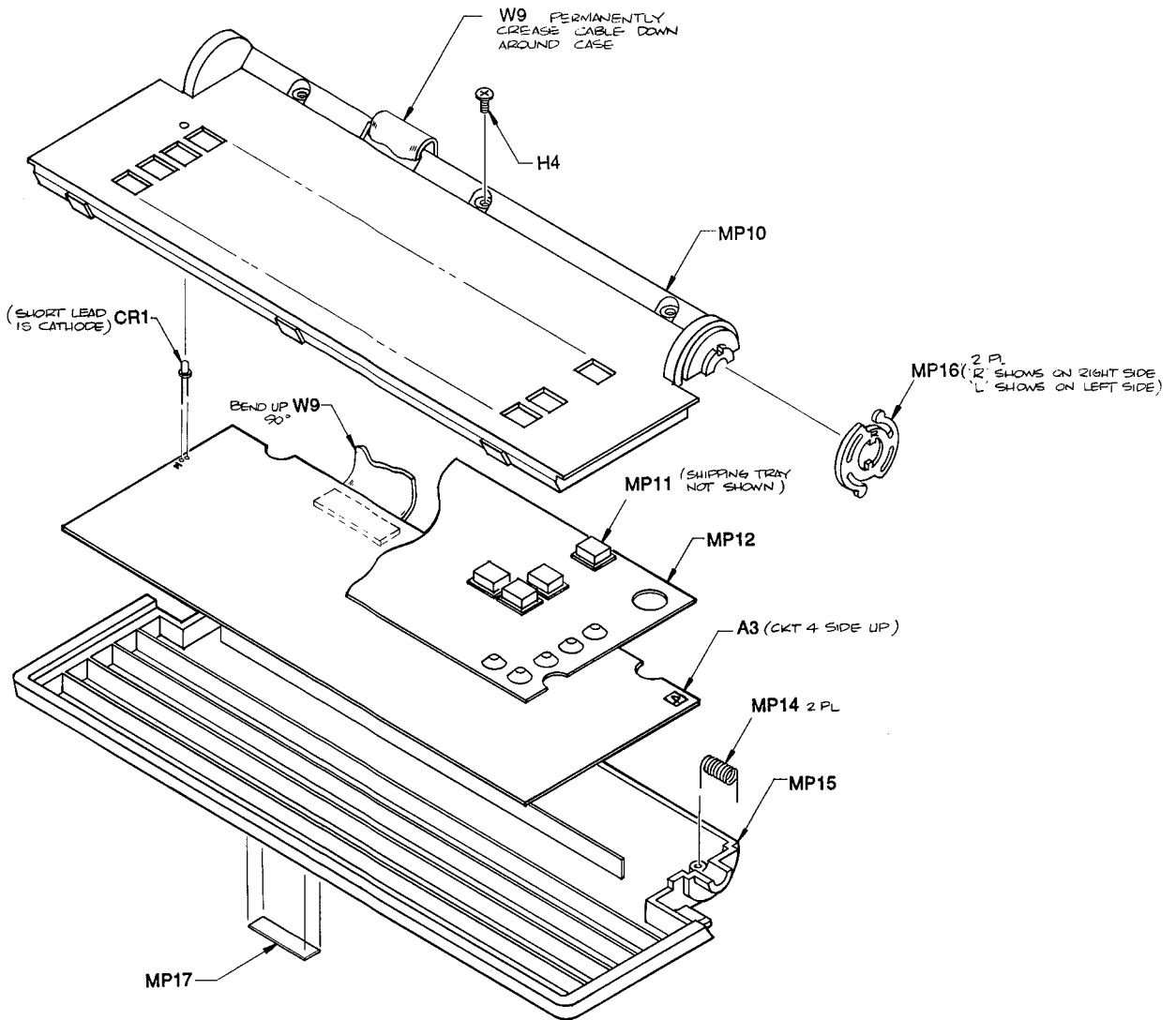

Figure 5-1. 9100 Series Final Assembly



9100A T&B
(2 of 9)

Figure 5-1. 9100 Series Final Assembly (cont.)

5/List of Replaceable Parts

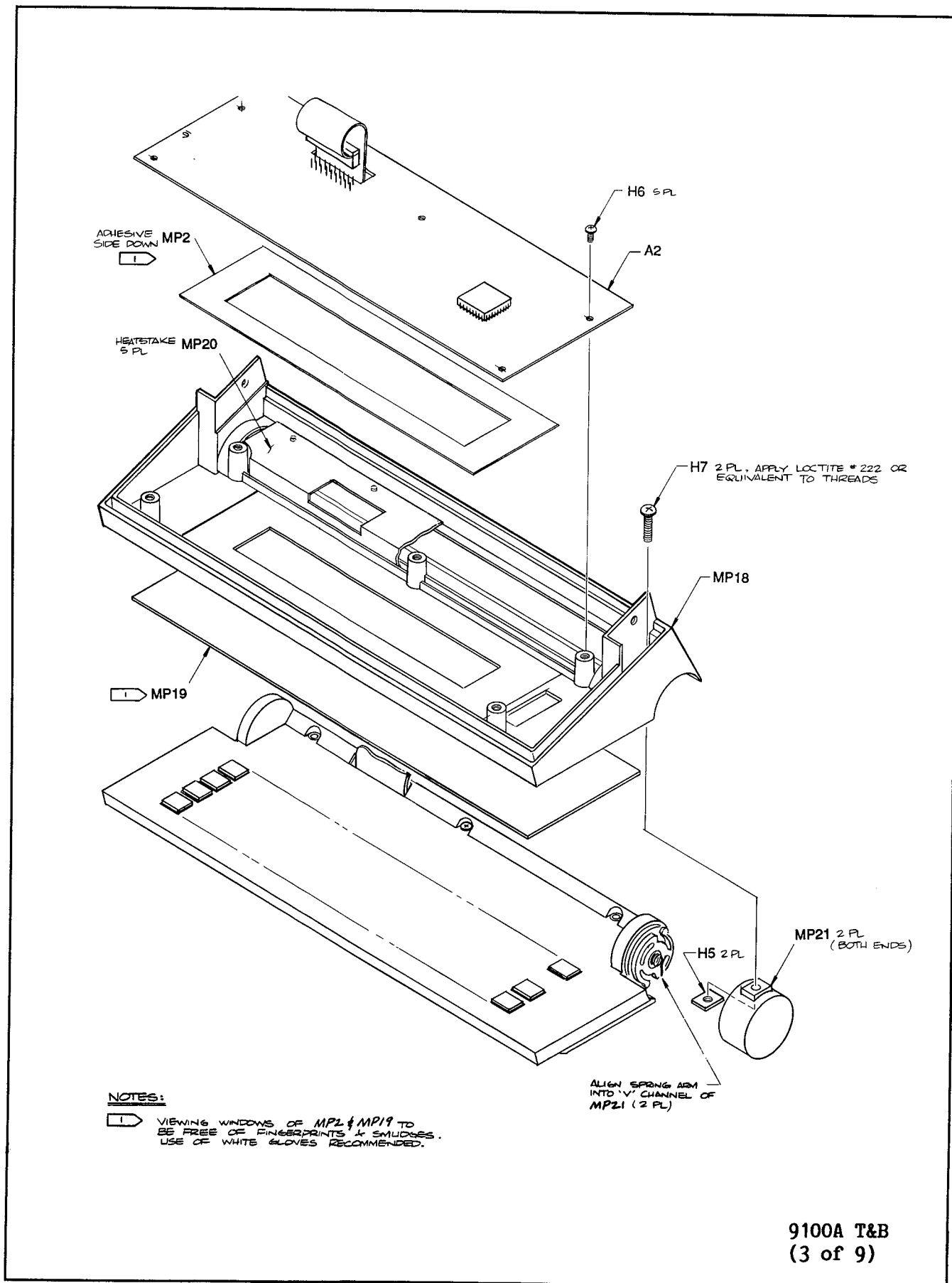

Figure 5-1. 9100 Series Final Assembly (cont.)

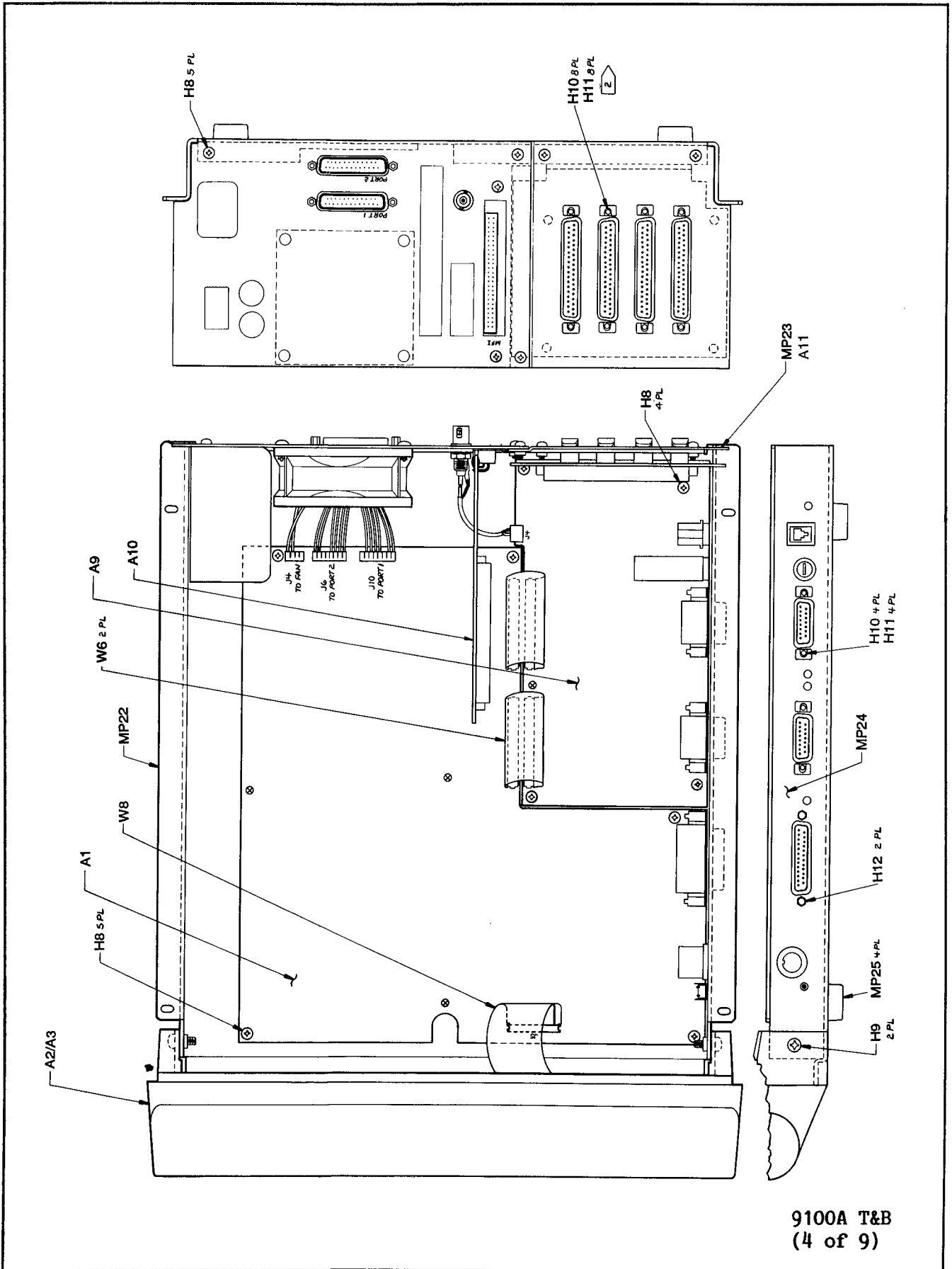

Figure 5-1. 9100 Series Final Assembly (cont.)

5/List of Replaceable Parts

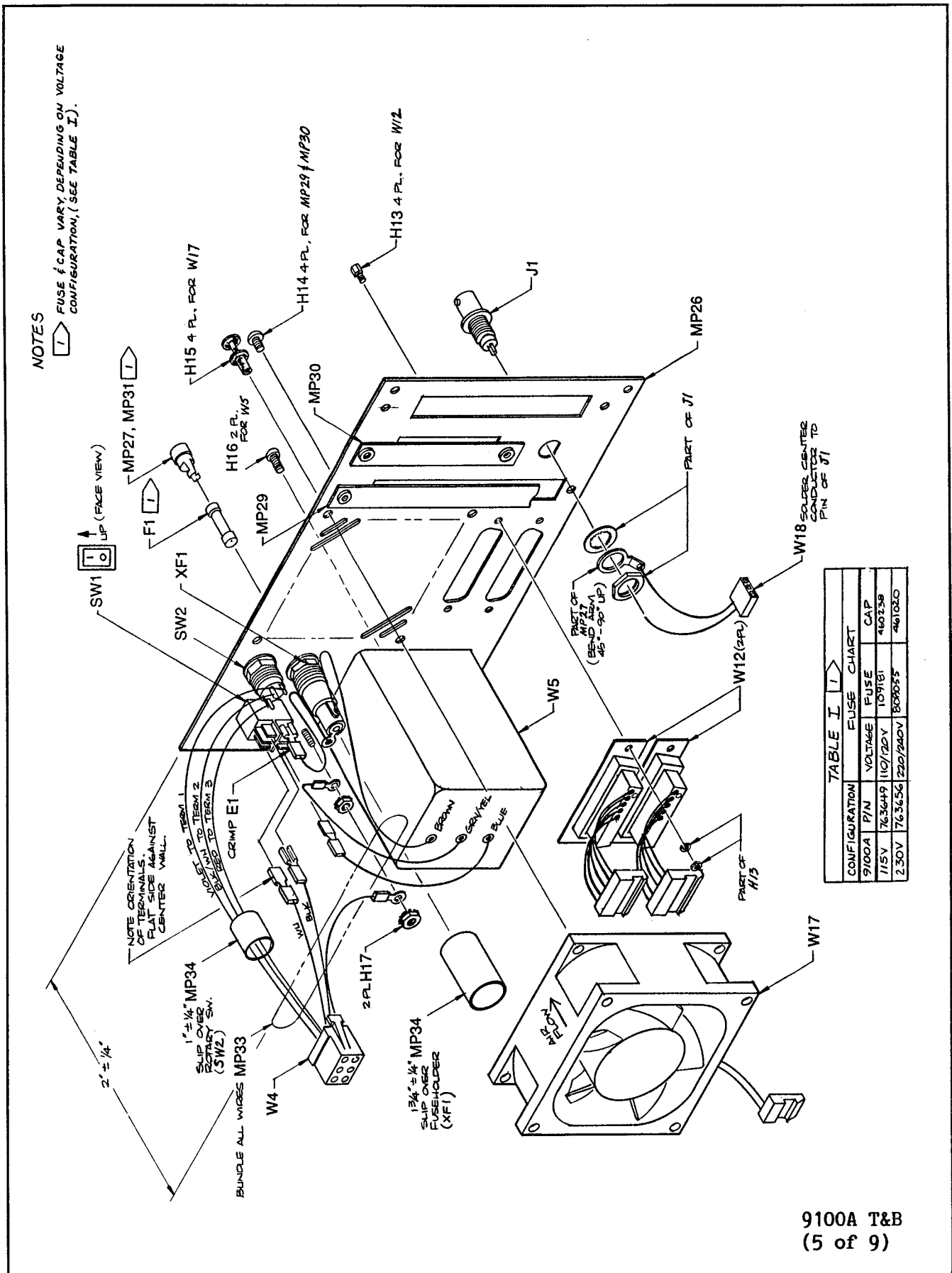

TABLE I

CONFIGURATION	FUSE	CHART
9100A	F1	FUSE
115V	76.36449	109181
2.30V	76.36456	808655
		461060

Figure 5-1. 9100 Series Final Assembly (cont.)

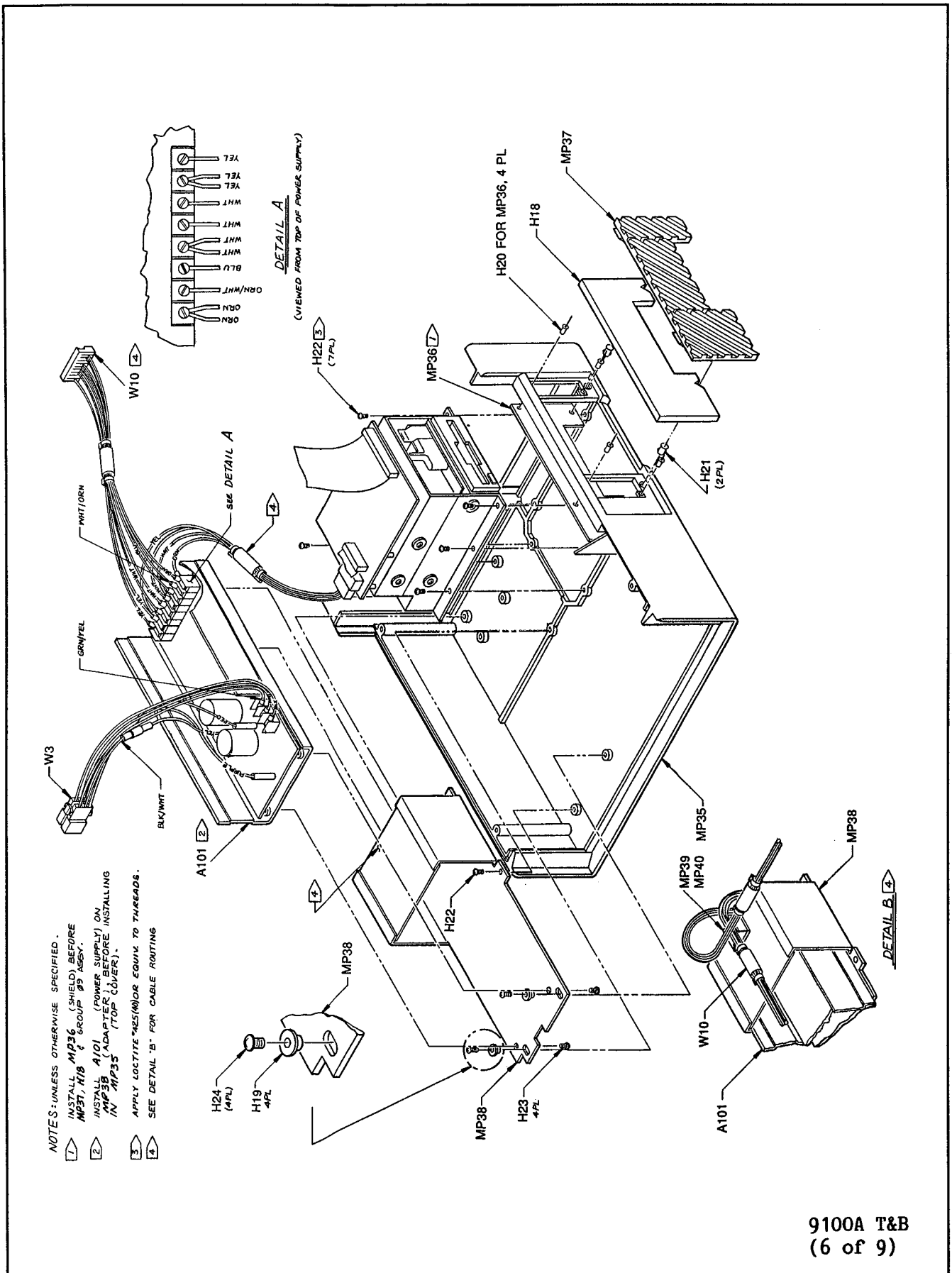

Figure 5-1. 9100 Series Final Assembly (cont.)

5/List of Replaceable Parts

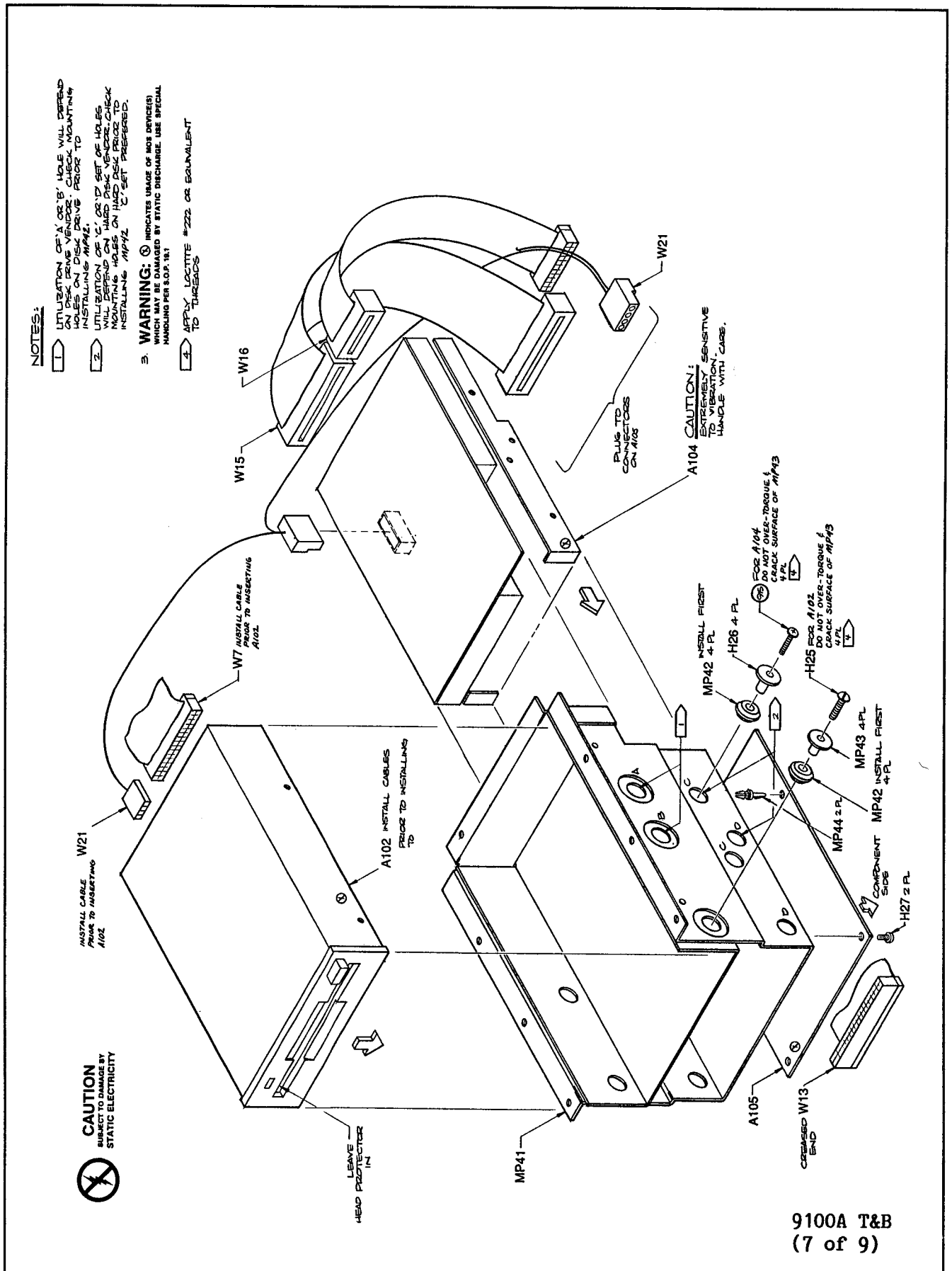
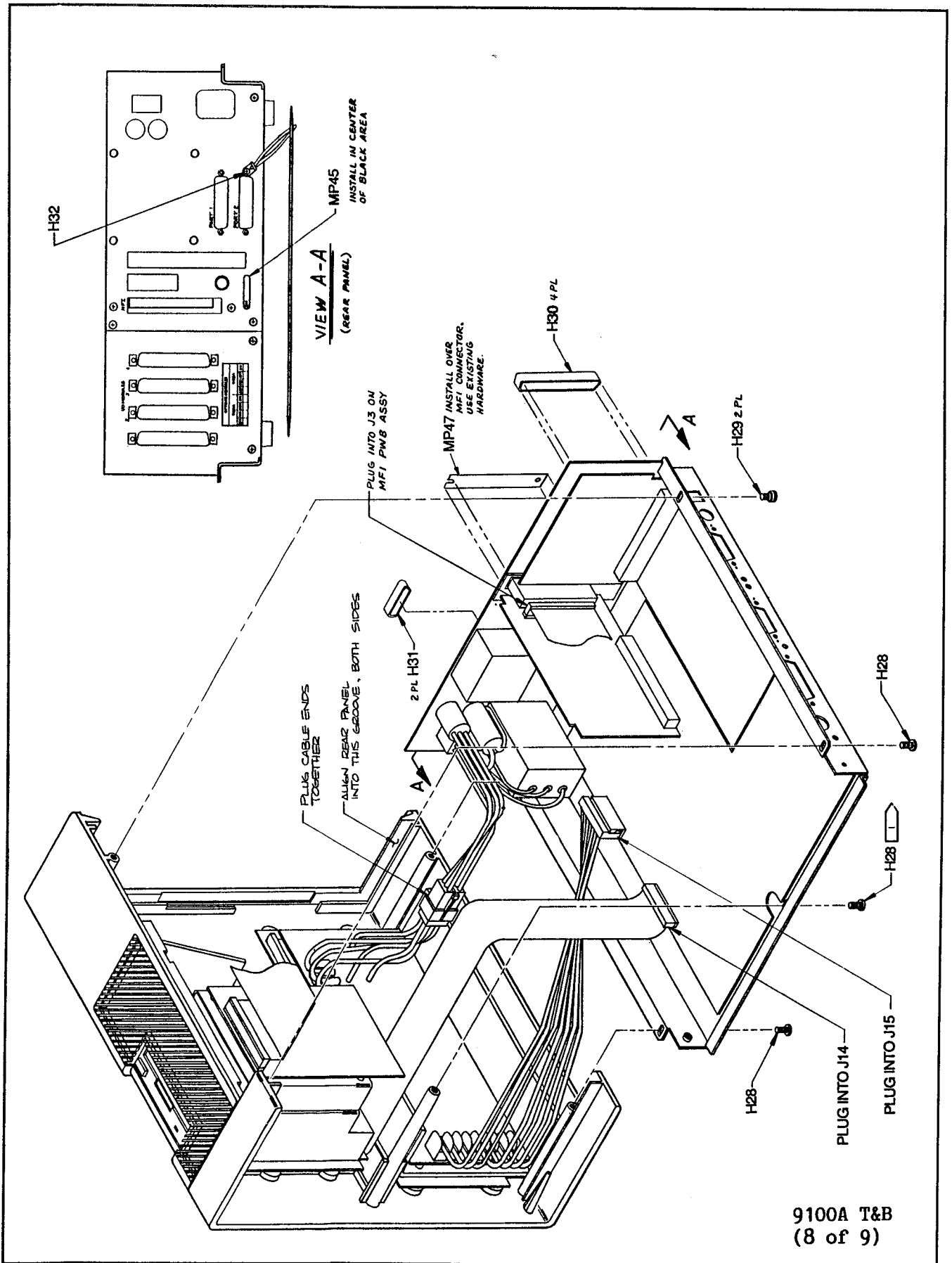
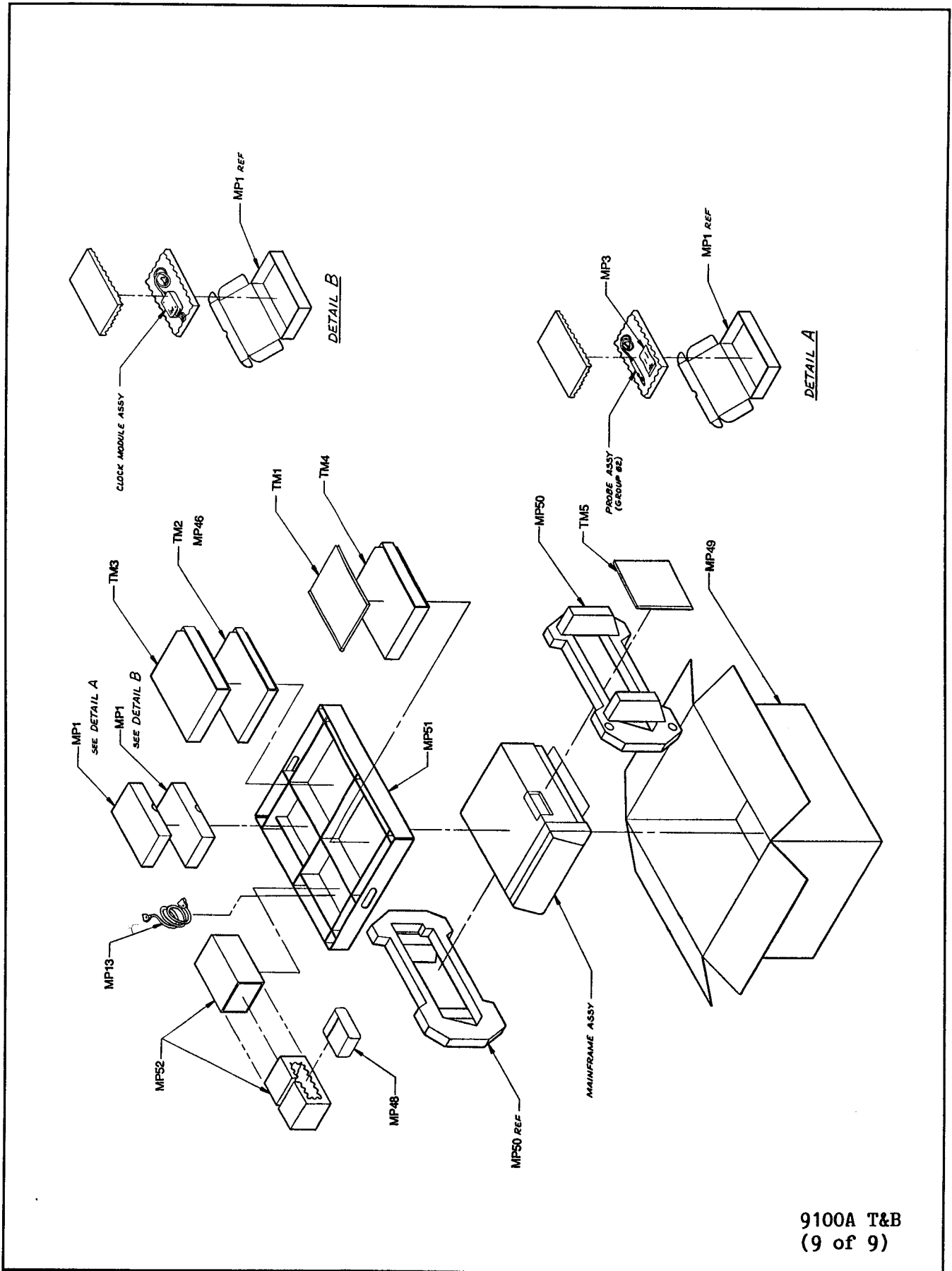

Figure 5-1. 9100 Series Final Assembly (cont.)



9100A T&B
(8 of 9)

Figure 5-1. 9100 Series Final Assembly (cont.)



9100A T&B
(9 of 9)

Figure 5-1. 9100 Series Final Assembly (cont.)

5/List of Replaceable Parts

Table 5-3. A1 Main PCA
(See Figure 5-2.)

REFERENCE DESIGNATOR	DESCRIPTION	FLUKE STOCK	MFRS SPLY	MANUFACTURERS PART NUMBER	TOT QTY	R S T	N O
-A>-NUMERICS----->	S-----DESCRIPTION-----	--NO--	-CODE-	-OR GENERIC TYPE-----	QTY-	-Q	-E-
C 1- 4, 6,	CAP, TA, 10UF, +-20%, 25V	772491	89536	772491	10		
C 23, 100-103		772491					
C 5	CAP, TA, 3.3UF, +-20%, 25V	780486	89536	780486	1	1	
C 10, 11, 18,	CAP, CER, 0.01UF, +-10%, 50V, X7R, 1206	747261	89536	747261	121		
C 19, 24, 110-		747261					
C 113, 120, 121,		747261					
C 130, 131, 200-		747261					
C 288, 300-310,		747261					
C 320, 321, 340-		747261					
C 343, 360, 361		747261					
C 12	CAP, CER, 1000PF, +-10%, 50V, COG, 1206	747378	89536	747378	1		
C 13	CAP, CER, 0.1UF, +-10%, 25V, X7R, 1206	747287	89536	747287	1		
C 14	CAP, CER, 10PF, +-10%, 50V, COG, 1206	747311	89536	747311	1		
C 16, 17, 20,	CAP, CER, 47PF, +-10%, 50V, COG, 1206	747352	89536	747352	4		
C 21		747352					
C 380	CAP, CER, 0.01UF, +-20%, 100V, X7R, 1206	742981	89536	742981	1		
CR 1- 3, 6-	DIODE, SI, BV=200V, IO=10A, DUAL, SOT89	742973	89536	742973	6	1	
CR 8		742973					
CR 4, 5	DIODE, SI, BV=75.0V, IO=100MA, MLF	742064	89536	742064	2	2	
CR 9, 10	DIODE, SI, SCHOTTKY, 30V, 1.1A, SOT89	782573	89536	782573	2	1	
F 1	FUSE, 5X20MM, FAST, 0.125A, 250V	573733	89536	573733	1	5	
J 1	HEADER, 1 ROW, 0.100CTR, 4 PIN	631184	89536	631184	1		
J 2, 3	HEADER, 1 ROW, 0.100CTR, 8 PIN	520502	22526	65502-408	2		
J 4, 6	CONN, DIN41612, TYPE R, 96 PIN	747808	89536	747808	2		
J 5	CONN, DIN41612, TYPE R, 64 PIN	782094	89536	782094	1		
J 7, 8	HEADER, 2 ROW, 0.100 CTR, 40 PIN	603670	89536	603670	2		
J 9	CONN, D-SUB, PWB, RT ANG, 25 SCKT	782144	89536	782144	1		
J 10	CONN, CIRC, DIN, RT ANG, PWB, 5 PIN @ 180	772178	89536	772178	1		
J 11	HEADER, 2 ROW, 0.100CTR, 20 PIN	782185	89536	782185	1		
J 14	HEADER, 2 ROW, 0.100CTR, 34 PIN	658047	89536	658047	1		
J 15	HEADER, 1 ROW, 0.156 CTR, 10 PIN	446724	27264	09-65-1101	1		
L 1, 2	CHOKE	502138	89536	502138	2		
Q 1, 2	* TRANSISTOR, SI, N-MOS, 1W, 4 PIN DIP	800391	89536	800391	2	1	
R 1	RES, CHIP, CERM, 56K, +-5%, 0.125W, 1206	746701	89536	746701	1		
R 2, 3, 6,	RES, CHIP, CERM, 10K, +-5%, 0.125W, 1206	746610	89536	746610	42		
R 7, 11- 15,		746610					
R 27- 29, 31-		746610					
R 35, 40, 43,		746610					
R 45- 48, 56-		746610					
R 63, 67, 70,		746610					
R 75, 76, 80,		746610					
R 83- 85, 87,		746610					
R 89, 90		746610					
R 4, 100-111,	RES, CHIP, CERM, 10, +-5%, 0.125W, 1206	746214	89536	746214	14		
R 116		746214					
R 5, 8- 10,	RES, CHIP, CERM, 4.7K, +-5%, 0.125W, 1206	740522	89536	740522	12		
R 21, 22, 30,		740522					
R 65, 69, 72,		740522					
R 82, 86		740522					
R 16, 17, 51-	RES, CHIP, CERM, 1.2K, +-5%, 0.125W, 1206	746412	89536	746412	10		
R 55, 71, 78,		746412					
R 88		746412					
R 18, 19, 36,	RES, CHIP, CERM, 39K, +-5%, 0.125W, 1206	746677	89536	746677	5		
R 37, 74		746677					
R 20, 38, 77	RES, CHIP, CERM, 3K, +-5%, 0.125W, 1206	746511	89536	746511	3		
R 23, 24	RES, CHIP, CERM, 390, +-5%, 0.125W, 1206	740498	89536	740498	2		
R 25, 26	RES, CHIP, CERM, 220, +-5%, 0.125W, 1206	746347	89536	746347	2		
R 39, 44, 79	RES, CHIP, CERM, 750, +-5%, 0.125W, 1206	746404	89536	746404	3		
R 41, 64, 66,	RES, CHIP, CERM, 33, +-5%, 0.125W, 1206	746248	89536	746248	9		
R 68, 91, 112-		746248					
R 115		746248					
R 42, 73	RES, CHIP, CERM, 100K, +-5%, 0.125W, 1206	740548	89536	740548	2		
R 49, 50	RES, CHIP, CERM, 510K, +-5%, 0.125W, 1206	746800	89536	746800	2		
R 81	RES, CHIP, CERM, 2.2K, +-5%, 0.125W, 1206	746479	89536	746479	1		
S 1	SWITCH, PUSHBUTTON, SPST, MOMENTARY	782433	89536	782433	1		
T 1	TRANSFORMER, CONVERTER	775932	89536	775932	1		
TP 1- 11	TERM, UNINSUL, WIRE FORM, TEST POINT	781237	89536	781237	11		
U 1, 4	* IC, BIPOLAR, DUAL RS-232 RECEIVER, SOIC	742395	89536	742395	2	1	
U 2, 3	* IC, BIPOLAR, DUAL RS-232 DRIVER, SOIC	742403	89536	742403	2	1	
U 5, 6	* ISOLATOR, HI-SPEED DUAL	742841	89536	742841	2	1	

An * in 'S' column indicates a static-sensitive part.

5/List of Replaceable Parts

Table 5-3. A1 Main PCA (cont.)

REFERENCE DESIGNATOR	FLUKE STOCK	MFRS SPLY	MANUFACTURERS PART NUMBER	TOT QTY	R O T	N
-A>-NUMERICS--> S	--NO--	-CODE-	-OR GENERIC TYPE----	-Q	-E-	
U 8, 35	* IC, LSTTL, HEX INVERTER, SOIC	741017	89536 741017	2	1	
U 9	* IC, CMOS, OCTL LINE DRVR, SOIC	742593	89536 742593	1	1	
U 10	* IC, LSTTL, 8BIT P/S-IN, S-OUT SHFT, SOIC	741983	89536 741983	1	1	
U 11	* IC, NMOS, EEPROM 2444	834416	89536 834416	1	1	
U 13- 16	* ASSEMBLY, RAM MODULE	809079	89536 809079	4		1
U 17	* IC, ALSTTL, 3-8 LINE DCDR W/ENABLE, SOIC	741686	89536 741686	1	1	
U 18	OSCILLATOR, 32MHZ, TTL CLOCK	742338	89536 742338	1		
U 19	* IC, FTTL, DUAL D F/F, +EDG TRG, SOIC	742163	89536 742163	1	1	
U 20	* IC, ASTTL, QUAD 2 INPUT NAND GATE, SOIC	782250	89536 782250	1	1	
U 21, 57	* IC, ALSTTL, QUAD 2 INPUT AND GATE, SOIC	741827	89536 741827	2	1	
U 22, 41, 82	* IC, LSTTL, QUAD 2 INPUT OR GATE, SOIC	740878	89536 740878	3	1	
U 23, 24	* IC, FTTL, 9 BIT PARITY GEN/CHECKER, SOIC	742478	89536 742478	2	1	
U 25, 91	* IC, ALSTTL, QUAD 2 INPUT NAND GATE, SOIC	782268	89536 782268	2	1	
U 26	* IC, LSTTL, 8-BIT BINARY CNTR W/REG, SOIC	782243	89536 782243	1	1	
U 27	* IC, LSTTL, OCTAL BUFFER INVERTED, SOIC	742627	89536 742627	1	1	
U 28	* IC, 16L8 LOGIC ARRAY	818203	89536 818203	1	1	
U 29- 31	* IC, ASTTL, QUAD 2-INPUT MUX, SOIC	811984	89536 811984	3	1	
U 32	* IC, NMOS, 16 BIT MICROPROCESSOR, PLCC	742429	89536 742429	1	1	
U 33	* IC, LSTTL, QUAD BUS, SOIC	740977	89536 740977	1	1	
U 34, 54	* IC, LSTTL, DUAL 4 INPUT NAND GATE, SOIC	742528	89536 742528	2	1	
U 36, 67, 74	* IC, ALSTTL, QUAD 2 INPUT NOR GATE, SOIC	782284	89536 782284	3	1	
U 37, 61- 63	* IC, LSTTL, OCTAL D F/F, +EDG TRG, SOIC	741975	89536 741975	4	1	
U 38, 89	* IC, ALSTTL, HEX INVERTERS, SOIC	782300	89536 782300	2	1	
U 39	* IC, LSTTL, QUAD 2 INPUT OR GATE, SOIC	742460	89536 742460	1	1	
U 40, 50, 81	* IC, LSTTL, 8BIT S-IN, P-OUT R-SHFT, SOIC	742106	89536 742106	3	1	
U 42, 58	* IC, LSTTL, OCTL LINE DRVR, SOIC	742122	89536 742122	2	1	
U 43	* IC, NMOS, FLOPPY DISK FORMTR CNTLR, PLCC	782870	89536 782870	1	1	
U 44	* IC, NMOS, FLOPPY DISK INT CKT, PLCC	782888	89536 782888	1	1	
U 46	* PROGRAMMED 27256 V3.0	828897	89536 828897	1	1	
U 47	* PROGRAMMED 27256 V3.0	828905	89536 828905	1	1	
U 49, 75	* IC, LSTTL, 8 TO 3 LINE ENCODER, SOIC	782326	89536 782326	2	1	
U 51, 64	* IC, LSTTL, QUAD 2 INPUT NAND GATE, SOIC	741033	89536 741033	2	1	
U 52	* IC, LSTTL, TRIPLE 3-INPUT AND GATE, SOIC	741264	89536 741264	1	1	
U 53, 60	* IC, LSTTL, OCTAL D F/F, +EDG TRG, SOIC	740928	89536 740928	2	1	
U 55, 90	* IC, ALSTTL, 8 INPUT NAND GATE, SOIC	782334	89536 782334	2	1	
U 56, 65, 78	* IC, LSTTL, QUAD 2 INPUT NOR GATE, SOIC	741025	89536 741025	3	1	
U 59	* IC, COMPARATOR, QUAD, 14 PIN, SOIC	741561	89536 741561	1	1	
U 66	* IC, LSTTL, TRIPLE 3 INPUT NOR GATE, SOIC	740993	89536 740993	1	1	
U 68	* IC, ALSTTL, DUAL 4 INPUT NAND GATE, SOIC	741645	89536 741645	1	1	
U 69	* IC, ALSTTL, TRIPLE 3INPUT NOR GATE, SOIC	782318	89536 782318	1	1	
U 70	* IC, LSTTL, 2-4 LINE DEMUX, SOIC	740951	89536 740951	1	1	
U 71	* IC, CMOS, HEX INVERTER W/SCHT TRIG, SOIC	780965	89536 780965	1	1	
U 72	* IC, TTL, HEX BUFFER W/OPEN COLL, SOIC	742387	89536 742387	1	1	
U 73	* IC, LSTTL, DUAL JK F/F, -EDG TRIG, SOIC	741256	89536 741256	1	1	
U 76	* IC, LSTTL, QUAD 2IN O/C NAND GATE, SOIC	782292	89536 782292	1	1	
U 77, 80	* IC, LSTTL, DUAL D F/F, +EDG TRG, SOIC	740985	89536 740985	2	1	
U 79	* IC, ALSTTL, DUAL D F/F, +EDG TRG, SOIC	742452	89536 742452	1	1	
U 83	SWITCH, MODULE, SPST, DIP, 8 POS	414490	00779 435166-5	1		
U 84	* IC, LSTTL, QUAD 2 INPUT AND GATE, SOIC	740860	89536 740860	1	1	
U 85	* IC, LSTTL, DUAL J-F F/F, +EDG TRIG, SOIC	742502	89536 742502	1	1	
U 86	* IC, LSTTL, DELAY ELEMENTS, SOIC	773077	89536 773077	1	1	
U 87	* IC, VOLT SUPERVISOR, 10V SENSE, SOIC	780502	89536 780502	1	1	
U 88	* IC, LSTTL, MONOSTAB MULTIVIB W/CLR, SOIC	742494	89536 742494	1	1	
XF 1	HOLDER, FUSE, 5X20MM, PCB	772475	89536 772475	2		
XU 13- 16	CONN, PWB EDGE, REC, 0.100CTR, 30 POS	806828	89536 806828	4	1	
XU 18	SPACER, DIP SOCKET, 14 PIN, PLASTIC	441865	32559 814-060	1		
XU 28	SOCKET, IC, 20 PIN	454421	09922 DILB20P-108	1		
XU 45- 48	SOCKET, IC, 28 PIN	448217	91506 328-AG39D	4		
Y 1	CRYSTAL, 3.6864MHZ, +/-50PPM, SURF.MNT.	800193	89536 800193	1	1	

An * in 'S' column indicates a static-sensitive part.

NOTES:

1 - See A16 on the Final Assembly for quantities and part numbers.

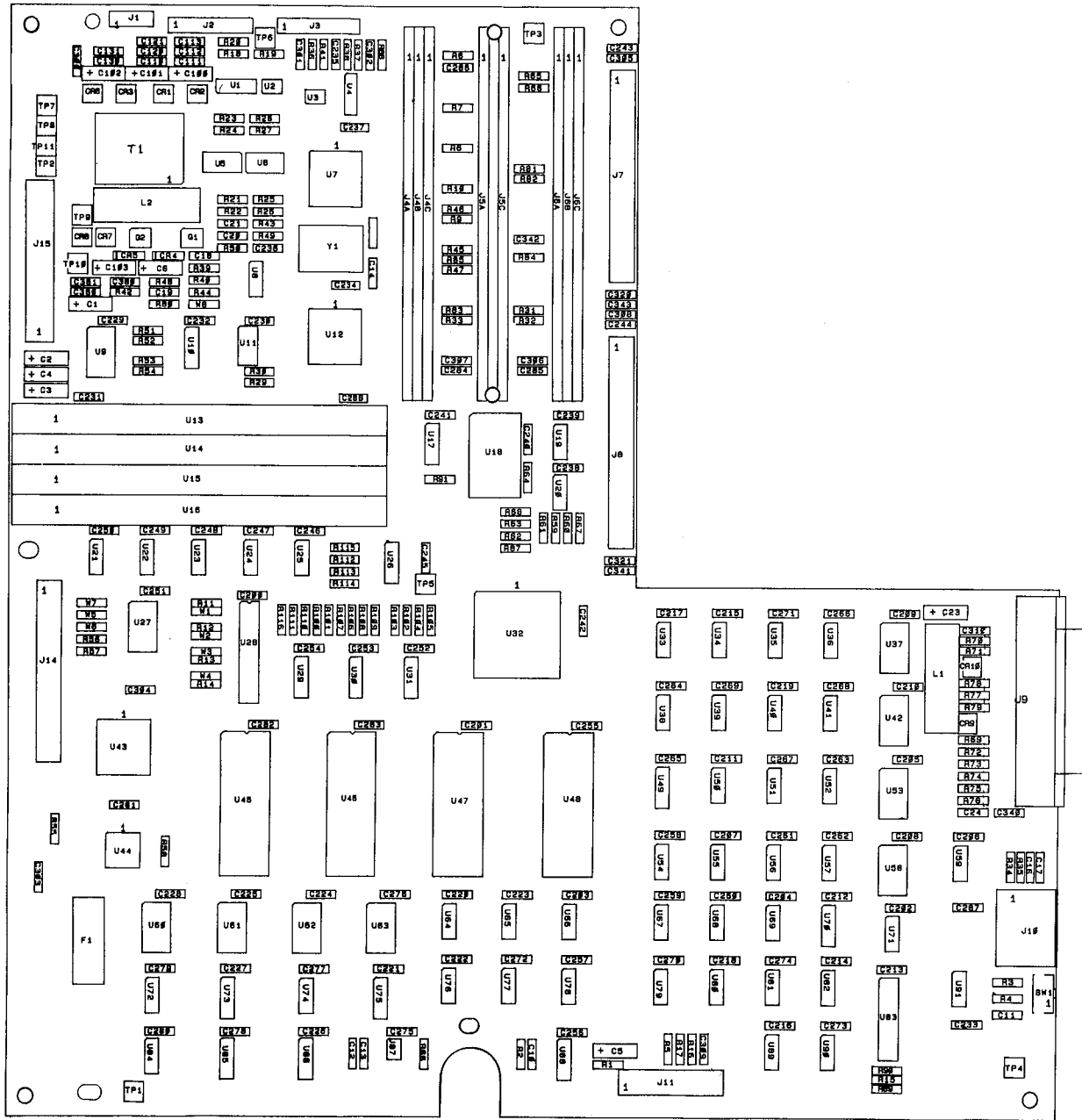

CAUTION
SUBJECT TO DAMAGE BY
STATIC ELECTRICITY

9100A-1601

Figure 5-2. A1 Main PCA

5/List of Replaceable Parts

Table 5-4. A2 Display Interface PCA
(See Figure 5-3.)

REFERENCE DESIGNATOR	FLUKE STOCK	MFRS SPLY	MANUFACTURERS PART NUMBER	TOT QTY	R O S T	N
-A>-NUMERICS--> S	--- <th>-CODE-</th> <th>-OR GENERIC TYPE----</th> <th>QTY-</th> <th>-Q</th> <th>-E-</th>	-CODE-	-OR GENERIC TYPE----	QTY-	-Q	-E-
C 1, 8	782409	89536	782409	2		
C 2	780478	89536	780478	1	1	
C 3, 4	772491	89536	772491	2		
C 5, 70- 78,	742981	89536	742981	41		
C 101-131	742981					
C 6, 7	747287	89536	747287	2		
CR 1- 7	504761	14936	MV57124	7	2	
E 1	602490	51406	EFB-RD24C01	1		
J 1, 2	782185	89536	782185	2		
MP 1	788570	89536	788570	1		
Q 1- 4	742023	89536	742023	4	1	
Q 5- 8	742031	89536	742031	4	1	
R 1- 4, 6-	746008	89536	746008	16		
R 13, 15, 16,	746008					
R 48, 49	746008					
R 5	740548	89536	740548	1		
R 14, 17	746024	89536	746024	2		
R 18, 19	745984	89536	745984	2		
R 20	746370	89536	746370	1		
R 21	740506	89536	740506	1		
R 22- 29	746610	89536	746610	8		
R 30, 31	746016	89536	746016	2		
R 32, 42- 47	746321	89536	746321	7		
R 33, 34, 41,	740522	89536	740522	4		
R 50	740522					
R 35, 36	746297	89536	746297	2		
R 37	746511	89536	746511	1		
R 38	746586	89536	746586	1		
R 39	746461	89536	746461	1		
R 40	746453	89536	746453	1		
TP 1- 7	781237	89536	781237	7		
U 1	800607	89536	800607	1	1	
U 1	818187	89536	818187	1	1	
U 2	741975	89536	741975	1	1	
U 3	742783	89536	742783	1	2	
U 4	741967	89536	741967	1	1	
U 5- 12	741231	89536	741231	8	2	
U 13, 14	740985	89536	740985	2	1	
U 15, 27	807578	89536	807578	2	1	
U 16	741033	89536	741033	1	1	
U 17, 31	741025	89536	741025	2	1	
U 18	742585	89536	742585	1	1	
U 19, 20	741264	89536	741264	2	1	
U 21	740878	89536	740878	1	1	
U 22	741249	89536	741249	1	1	
U 23, 24	782904	89536	782904	2	1	
U 25, 30	741769	89536	741769	2	1	
U 26	742007	89536	742007	1	1	
U 28	741991	89536	741991	1	1	
U 29	741959	89536	741959	1	1	
VF 1	742056	89536	742056	1		
VR 1- 2	800599	89536	800599	2	1	
XU 1	429282	09922	DILB40P-108	1		
Y 1	800383	89536	800383	1		

An * in 'S' column indicates a static-sensitive part.

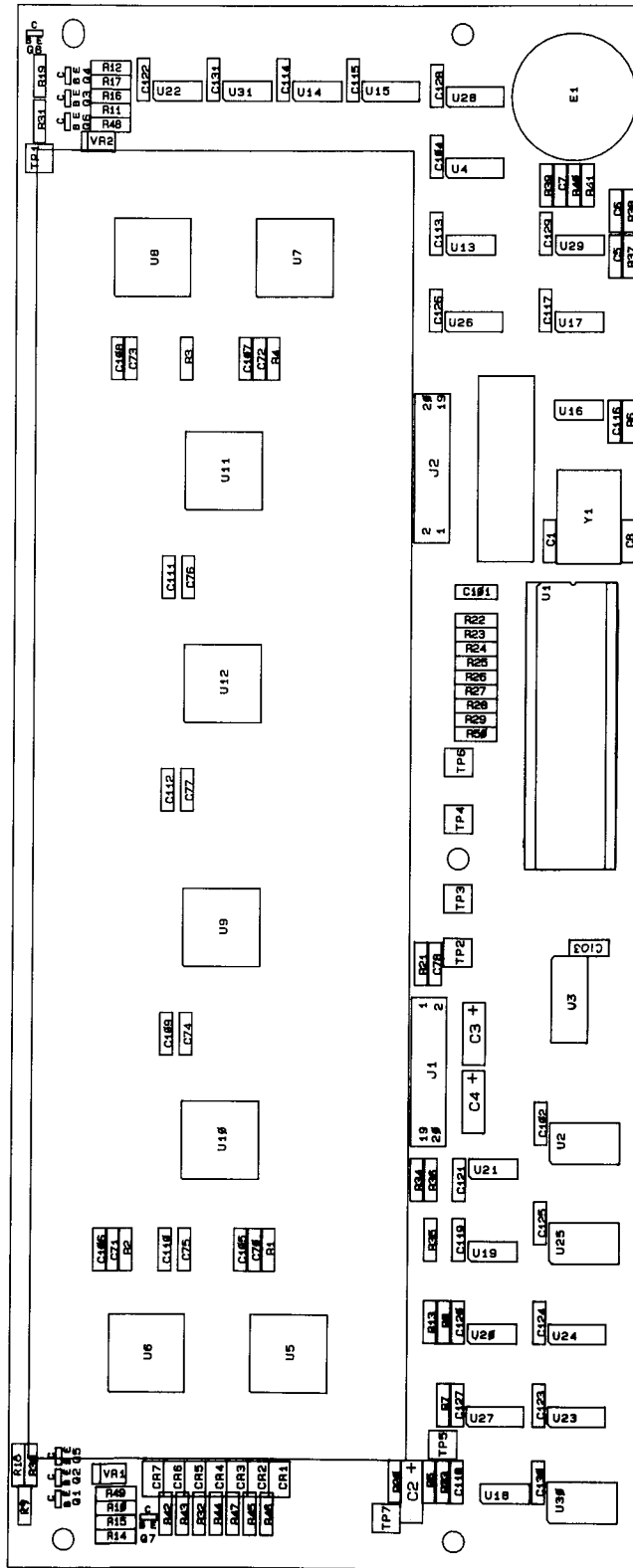

9100A-1602

Figure 5-3. A2 Display Interface PCA

5/List of Replaceable Parts

Table 5-5. A4 Video Controller PCA
(See Figure 5-4.)

REFERENCE DESIGNATOR	FLUKE STOCK	MFRS SPLY	MANUFACTURERS PART NUMBER	TOT QTY	R S	N T	O E
-A> NUMERICS-----> S-----DESCRIPTION-----	-NO--	-CODE-	-OR GENERIC TYPE-----		-Q-		
C 1, 101-131	747261	89536	747261	32			
C 2, 8	747287	89536	747287	2			
C 3, 7	772491	89536	772491	2	1		
C 4- 6	769240	89536	769240	3			
C 9, 10	740589	89536	740589	2			
H 1	183574	89536	183574	2			
J 1	782102	89536	782102	1			
J 2	782789	89536	782789	1			
Q 1	742676	89536	742676	1	1		
Q 2	742684	89536	742684	1	1		
R 1- 5, 14,	746370	89536	746370	7			
R 15	746370						
R 6, 13	746388	89536	746388	2			
R 7- 11	769828	89536	769828	5			
R 12	745992	89536	745992	1			
R 16	740506	89536	740506	1			
R 17	746263	89536	746263	1			
R 18	746347	89536	746347	1			
R 19	746495	89536	746495	1			
R 20	746446	89536	746446	1			
R 21	746560	89536	746560	1			
R 22, 23	746230	89536	746230	2			
R 24, 25	746610	89536	746610	2			
TP 1- 10	781237	89536	781237	10			
U 1	742734	89536	742734	1	1		
U 2	742742	89536	742742	1	1		
U 3, 4	742783	89536	742783	2	1		
U 5	818195	89536	818195	1	1		
U 6- 8	773028	89536	773028	3	1		
U 9, 10	742122	89536	742122	2	1		
U 11, 12	742726	89536	742726	2	1		
U 13	741975	89536	741975	1	1		
U 14	742619	89536	742619	1	1		
U 15	742700	89536	742700	1	1		
U 16- 19	741033	89536	741033	4	1		
U 20, 21	741264	89536	741264	2	1		
U 22	741017	89536	741017	1	1		
U 23	742510	89536	742510	1	1		
U 24	807578	89536	807578	1	1		
U 25	742692	89536	742692	1	1		
U 26	740860	89536	740860	1	1		
U 27	742627	89536	742627	1	1		
U 28	418285	28480	5082-4364	1	1		
U 29- 31	742817	89536	742817	3	1		
XU 5	448217	91506	328-AG39D	1			
XY 1	441865	32559	814-060	1			
XZ 1, 2	276535	91506	316-AG39D	2			
Y 1	800029	89536	800029	1			

An * in 'S' column indicates a static-sensitive part.

5/List of Replaceable Parts

Table 5-6. A5 Probe Assembly
(See Figure 5-5.)

REFERENCE DESIGNATOR		FLUKE STOCK	MFRS SPLY	MANUFACTURERS PART NUMBER	TOT QTY-	N R S T	O T E-
-A>-NUMERICS----->	S-----	DESCRIPTION-----	--NO--	-CODE-	-OR GENERIC TYPE-----	-Q-	-E-
C	1	CAP, CER, 27PF, +-10%, 50V, COG, 1206	800508	89536	800508	1	
C	2, 5	CAP, CER, 1000PF, +-10%, 50V, COG, 1206	747378	89536	747378	2	
C	3, 4	CAP, CER, 0.22UF, +80-20%, 50V, Y5V, 1206	740597	89536	740597	2	
C	6	CAP, CER, 0.22UF, +80-20%, 50V, Y5V, 1206	740597	89536	740597	1	
CR	1- 4	DIODE, SI, BV=75.0V, IO=100MA, MLF	742064	89536	742064	4	1
CR	5	DIODE, SI, BV=75.0V, IO=100MA, MLF	742064	89536	742064	1	1
L	1- 3	LAMP, SUB-MIN, 5V, 20MA	836239	89536	836239	3	5
MP	1	CONNECTOR, GROUND CLIP, FINISHED	788026	89536	788026	1	1
MP	2	COVER, PROBE	773309	89536	773309	1	
MP	3	KEYTOP	773333	89536	773333	1	
MP	4	BODY, PROBE	773317	89536	773317	1	
MP	5	DECAL, PROBE CONNECTOR	773929	89536	773929	1	
Q	1, 2	TRANSISTOR, SI, PNP, SMALL SIGNAL, SOT23	742023	89536	742023	2	1
Q	3, 4	TRANSISTOR, SI, NPN, SMALL SIGNAL, SOT23	742031	89536	742031	2	1
R	1	RES, CHIP, CERM, 220, +-5%, 0.125W, 1206	746347	89536	746347	1	
R	2	RES, CHIP, CERM, 100K, +-1%, 0.125W, 1206	769802	89536	769802	1	1
R	3, 8, 10	RES, CHIP, CERM, 200, +-5%, 0.125W, 1206	746339	89536	746339	3	
R	4	RES, CHIP, CERM, 330, +-5%, 0.125W, 1206	746370	89536	746370	1	
R	5, 7	RES, CHIP, CERM, 470, +-5%, 0.125W, 1206	740506	89536	740506	2	
R	6	RES, CHIP, CERM, 470, +-5%, 0.125W, 1206	740506	89536	740506	1	
R	9	RES, CHIP, CERM, 205K, +-1%, 0.125W, 1206	769836	89536	769836	1	1
R	11- 13	RES, CHIP, CERM, 1K, +-5%, 0.125W, 1206	745992	89536	745992	3	
S	1	SWITCH, PUSHBUTTON, SPST, MOMENTARY	782656	89536	782656	1	3
U	1	* IC, FTTL, HEX INVERT W/SCHMT TRIG, SOIC	742825	89536	742825	1	1
W	1	WIRE, TEF, E, 28AWG, STRN, BLU	558320	89536	558320	1	
W	2	CABLE ASSY, PROBE	783951	89536	783951	1	

An * in 'S' column indicates a static-sensitive part.

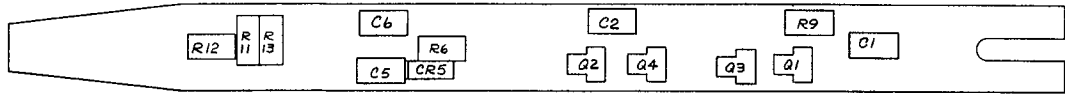

CKT 1

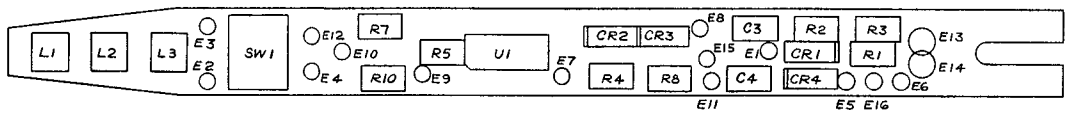

CKT 2

9100A-1605

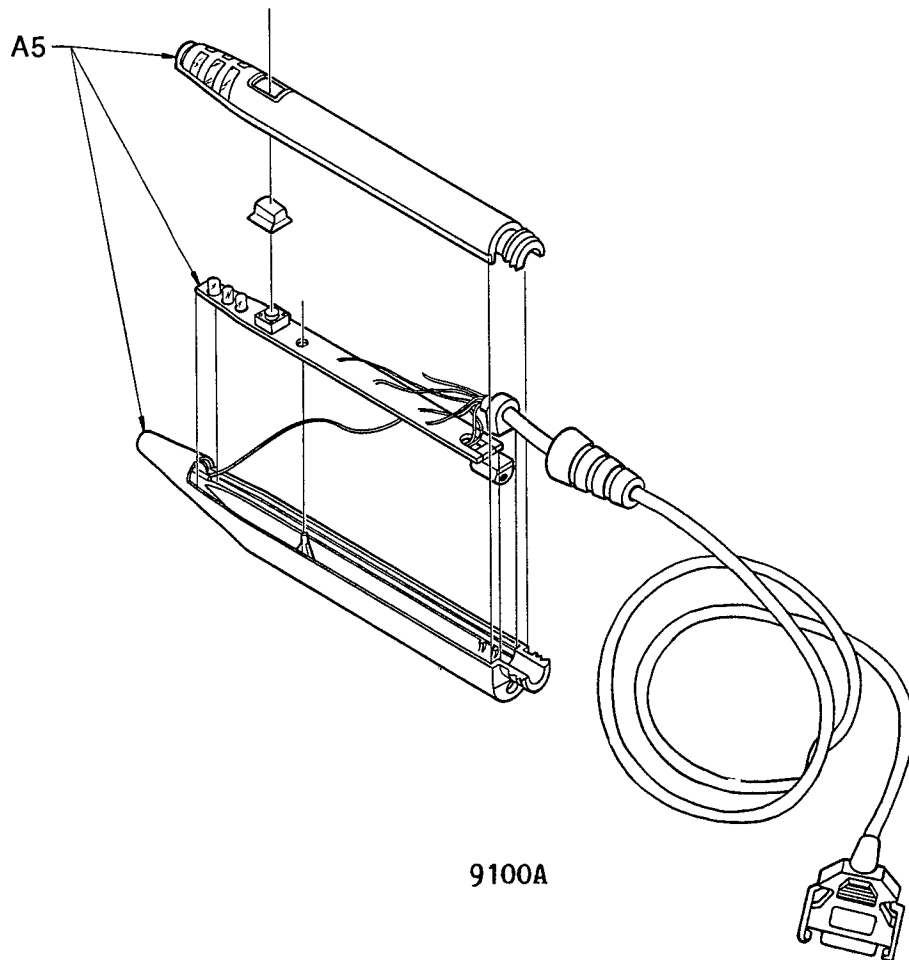

9100A

Figure 5-5. A5 Probe PCA

5/List of Replaceable Parts

Table 5-7. A6 Clock Module PCA
(See Figure 5-6.)

REFERENCE DESIGNATOR	FLUKE STOCK	MFRS SPLY	MANUFACTURERS PART NUMBER	TOT QTY	N R S T
-A>-NUMERICS-----> S-----DESCRIPTION-----	--NO--	-CODE-	-OR GENERIC TYPE-----		-Q -E-
C 1- 4	747303	89536	747303	4	
C 5- 12, 14	747261	89536	747261	9	
C 13	772491	89536	772491	1	
CR 1- 4	742320	89536	742320	4	
F 1	109314	71400	AGC1-4	1	5
F 1	543504	71400	GMA1-4	1	5
J 1- 5	233411	00779	60599-3	5	
J 6	417030	89536	417030	1	
MP 1	460238	61935	031.1666	1	
MP 1	461020	89536	461020	1	
R 1- 8	746651	89536	746651	8	
R 9- 12	769752	89536	769752	4	
R 13, 24- 27	746297	89536	746297	5	1
R 14	769745	89536	769745	1	
R 15- 22	746370	89536	746370	8	
R 23	746610	89536	746610	1	
U 1, 2	* 782219	89536	782219	2	1
XF 1	602763	89536	602763	1	
XU 1, 2	276535	91506	316-AG39D	2	

An * in 'S' column indicates a static-sensitive part.

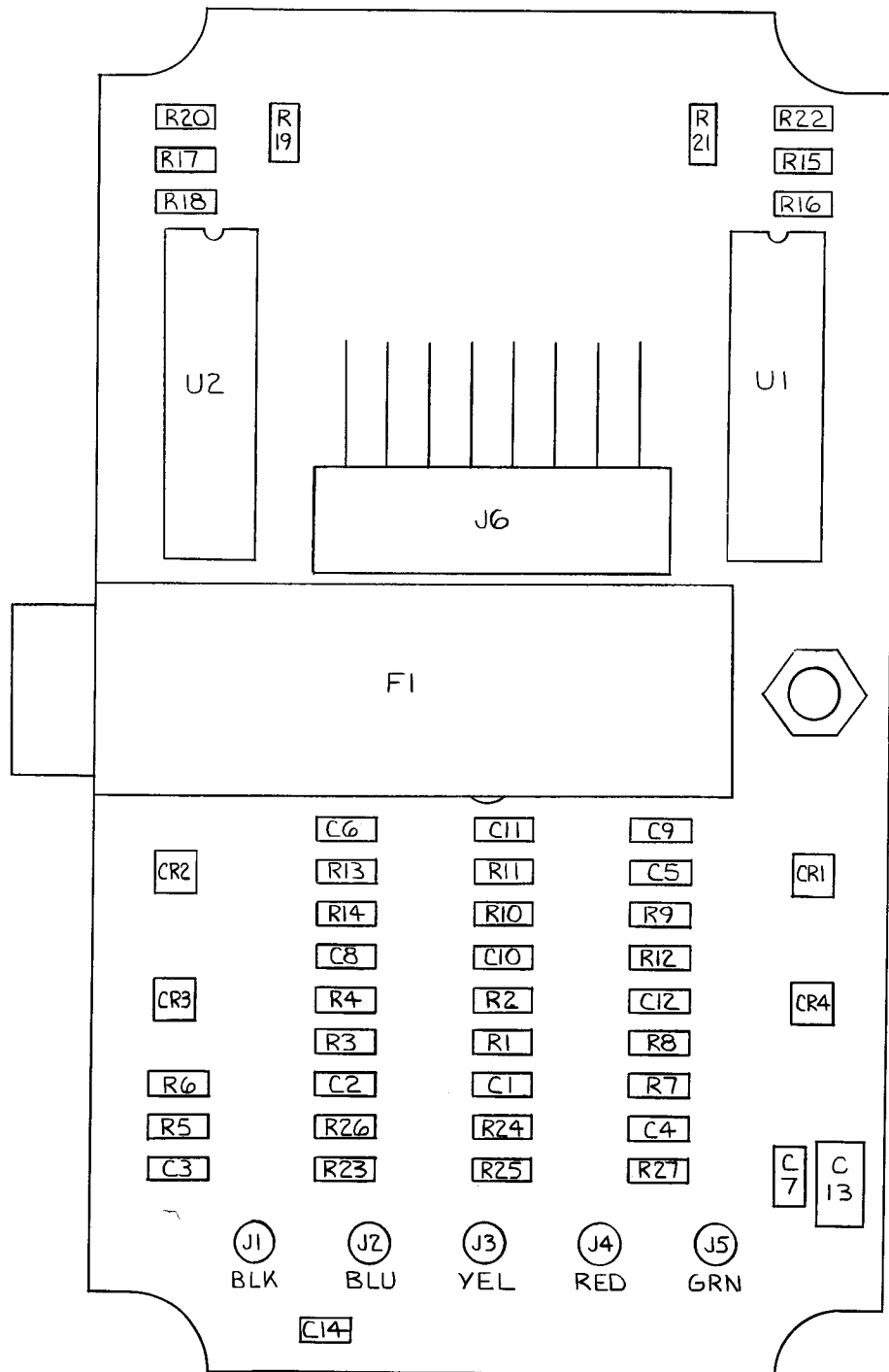

9100A-1606

Figure 5-6. A6 Clock Module PCA

5/List of Replaceable Parts

Table 5-8. A7 I/O Module Main PCA
(See Figure 5-7.)

REFERENCE DESIGNATOR	FLUKE STOCK	MFRS SPLY	MANUFACTURERS PART NUMBER	TOT QTY	R S T	N O T
-A>-NUMERIC-->	-----DESCRIPTION-----	--NO--	-OR GENERIC TYPE-----	QTY-	-Q	-E-
C 1, 2, 9-	CAP, TA, 10UF, +-20%, 25V	772491	89536 772491	27		
C 24, 27, 37,		772491				
C 42- 44, 61,		772491				
C 62, 67, 68		772491				
C 3- 7, 28-	CAP, CER, 0.01UF, +-10%, 50V, X7R, 1206	747261	89536 747261	31		
C 36, 38, 39,		747261				
C 46- 60		747261				
C 45	CAP, CER, 0.1UF, +-10%, 25V, X7R, 1206	747287	89536 747287	1		
CR 1- 4, 7,	DIODE, SI, BV=70.0V, IO=50MA, DUAL, SOT23	742320	89536 742320	85	5	
CR 100-179		742320				
CR 5, 6	DIODE, SI, BV=75.0V, IO=100MA, MLF	742064	89536 742064	2	1	
CR 8	DIODE, SI, SCHOTTKY, 30V, 1.1A, SOT89	782573	89536 782573	1	1	
E 1- 5	PIN, SINGLE, PWB, 0.058 DIA	233411	00779 60599-3	5		
F 1	FUSE, 1/4 X 1-1/4, SLOW, 1.0A, 250V	109272	89536 109272	1	5	
F 1	FUSE, 5X20MM, SLOW, 1A, 250V	808055	89536 808055	1	5	
H 1	SCREW, MACH, PHP SEMS, STL, 6-32X1/4	178533	89536 178533	1		
J 1	HEADER, 2 ROW, 0.100CTR, RT ANG, 38 PIN	782748	89536 89536	1		
J 2, 3	SOCKET, 2 ROW, PWB, 0.100CTR, 30 POS	783795	89536 783795	2		
MP 1	SPACER, HEX, ALUM, 6-32X0.625	104448	89536 104448	1		
P 1	HEADER, 1 ROW, 0.150CTR, RT ANG, 6 PIN	783803	89536 783803	1		
Q 1, 2	TRANSISTOR, SI, PNP, SMALL SIGNAL, SOT23	742684	89536 742684	2	1	
R 1, 2	RES, CHIP, CERM, 100, +-5%, 0.125W, 1206	746297	89536 746297	2		
R 3, 5, 6,	RES, CHIP, CERM, 10K, +-1%, 0.125W, 1206	769794	89536 769794	4		
R 10		769794				
R 4, 9	RES, CHIP, CERM, 42.2K, +-1%, 0.125W, 1206	769851	89536 769851	2		
R 7	RES, CHIP, CERM, 7.5K, +-1%, 0.125W, 1206	811463	89536 811463	1		
R 8	RES, CHIP, CERM, 825, +-1%, 0.125W, 1206	811455	89536 811455	1		
R 13, 14	RES, CHIP, CERM, 9.1K, +-5%, 0.125W, 1206	746602	89536 746602	2		
R 15, 17	RES, CHIP, CERM, 43K, +-5%, 0.125W, 1206	769299	89536 769299	2		
R 16, 18	RES, CHIP, CERM, 910, +-5%, 0.125W, 1206	769257	89536 769257	2		
R 19, 20, 23-	RES, CHIP, CERM, 4.7K, +-5%, 0.125W, 1206	740522	89536 740522	10		
R 30		740522				
R 21, 22, 31,	RES, CHIP, CERM, 1K, +-5%, 0.125W, 1206	745992	89536 745992	7		
R 33, 34, 39,		745992				
R 40		745992				
R 32	RES, CHIP, CERM, 11K, +-5%, 0.125W, 1206	769752	89536 769752	1		
TP 1- 8	TERM, UNINSUL, WIRE FORM, TEST POINT	781237	89536 781237	8		
U 1	OSCILLATOR, 1 MHZ, TTL CLOCK	634113	89536 634133	1		
U 2	* IC, OP AMP, QUAD, LOW POWER, SOIC	742569	89536 742569	1	1	
U 3, 5	* IC, LSTTL, QUAD 2 INPUT AND GATE, SOIC	740860	89536 740860	2	1	
U 4	* IC, CMOS, HEX INVERTER, SOIC	742585	89536 742585	1	1	
U 6	* IC, LSTTL, 3-8 LINE DCDR W/ENABLE, SOIC	740969	89536 740969	1	1	
U 7	* IC, LSTTL, OCTL D TRNSPRNT LATCHES, SOIC	742726	89536 742726	1	1	
U 8	* IC, CMOS, OCTAL BUS TRANSCEIVER, SOIC	742577	89536 742577	1	1	
U 9	* IC, ECL, QUAD ECL-TTL TRANSLATOR	801274	89536 801274	1	1	
U 10	* IC, LSTTL, QUAD 2 INPUT OR GATE, SOIC	740878	89536 740878	1	1	
U 11, 12	* IC, LSTTL, DUAL JK F/F, -EDG TRIG, SOIC	741256	89536 741256	2	1	
U 13, 16, 17	* IC, CMOS, OCTL LINE DRVR, SOIC	742593	89536 742593	3	2	
U 14	* IC, LSTTL, OCTAL D F/F, +EDG TRG, SOIC	740928	89536 740928	1	1	
U 15	* IC, LSTTL, SINGLE 8-INP. NAND GATE, SOIC	742510	89536 742510	1	1	
U 18	* IC, CMOS, DUAL 4-1 SELECT/MUX, SOIC	780767	89536 780767	1	1	
U 100, 110, 120,	* IC CMOS QUEST 9000 CHIP CERAMIC TEST	760785	89536 760785	5	1	
U 130, 140	*	760785				
U 101, 103, 111,	* TRANSISTOR, SI, P-DMOS, POWER FET, 14 PIN	800185	89536 800185	10	2	
U 113, 121, 123,	*	800185				
U 131, 133, 141,	*	800185				
U 143	*	800185				
U 102, 104, 112,	* TRANS, SI, N-DMOS PWR FET, QUAD	782557	89536 782557	10	2	
U 114, 122, 124,	*	782557				
U 132, 134, 142,	*	782557				
U 144	*	782557				
U 105, 106, 115,	* IC, CMOS, OCTL LINE DRVR, SOIC	801043	89536 801043	10	1	
U 116, 125, 126,	*	801043				
U 135, 136, 145,	*	801043				
U 146	*	801043				
XF 1	HLDL PART, FUSE, BODY, PWB MT	602763	89536 602763	1		
XY 1	SPACER, DIP SOCKET, 14 PIN, PLASTIC	441865	32559 814-060	1		
Z 1, 100, 110,	RES, NET, DIP, 16PIN, 8RES, 100, +-5%	780460	89536 780460	6	1	
Z 120, 130, 140		780460				

An * in 'S' column indicates a static-sensitive part.

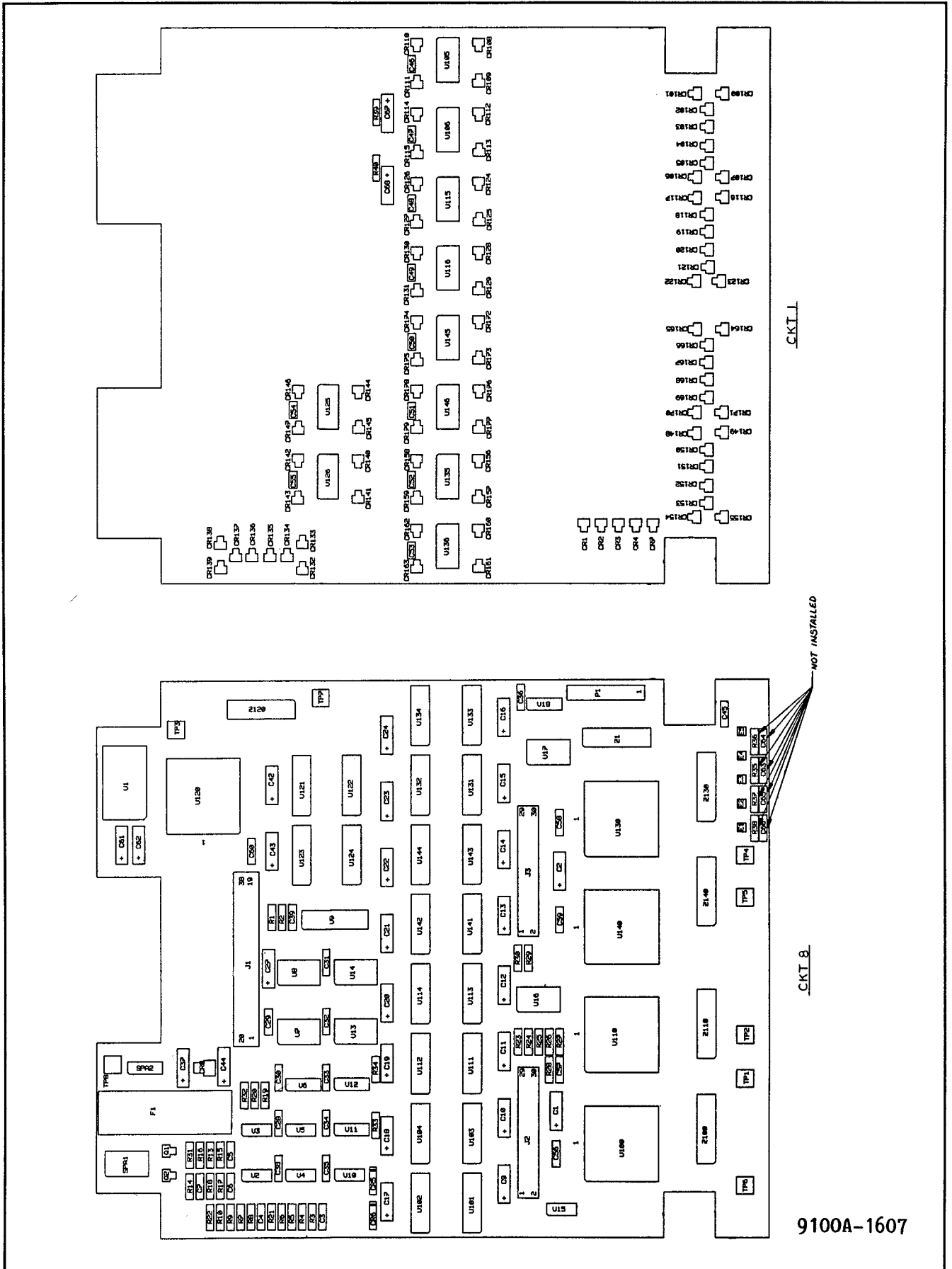

Figure 5-7. A7 I/O Module (Main) PCA

5/List of Replaceable Parts

Table 5-9. A8 I/O Module (Top) PCA
(See Figure 5-8.)

REFERENCE DESIGNATOR			FLUKE STOCK	MFRS SPLY	MANUFACTURERS PART NUMBER	TOT	N R O S T
-A>-NUMERICS----->	S-----	DESCRIPTION-----	--NO--	-CODE-	-OR GENERIC TYPE-----	QTY-	-Q -E-
C	1- 4	CAP, AL, 4700UF, +-20%, 16V, SOLV PROOF	800904	89536	800904	4	1
CR	1- 4	* DIODE, SI, 100 PIV, 1.0 AMP	343491	01295	1N4002	4	1
H	1	SCREW, MACH, PHP SEMS, STL, 6-32X1/4	178533	89536	178533	2	
H	2	SCREW, MACH, PHP SEMS, STL, 4-40X3/16	732750	89536	732750	4	
J	1, 4	HEADER, 2 ROW, 0.100CTR, 30 PIN	801233	89536	801233	2	
J	2, 3	CONN, RECT, PWB, REC, 33 POS	800672	89536	800672	2	
MP	1	COVER, SHIELD I/O MODULE	768036	89536	768036	1	
MP	2	SPACER, SWAGED, RND, BRASS, 6-32X0.590	811224	89536	811224	5	
MP	3	SPACER, SWAGED, RND, BRASS, 6-32X0.250	446351	89536	446351	2	
P	1- 4	GUIDE SOCKET	805648	89536	805648	4	

An * in 'S' column indicates a static-sensitive part.

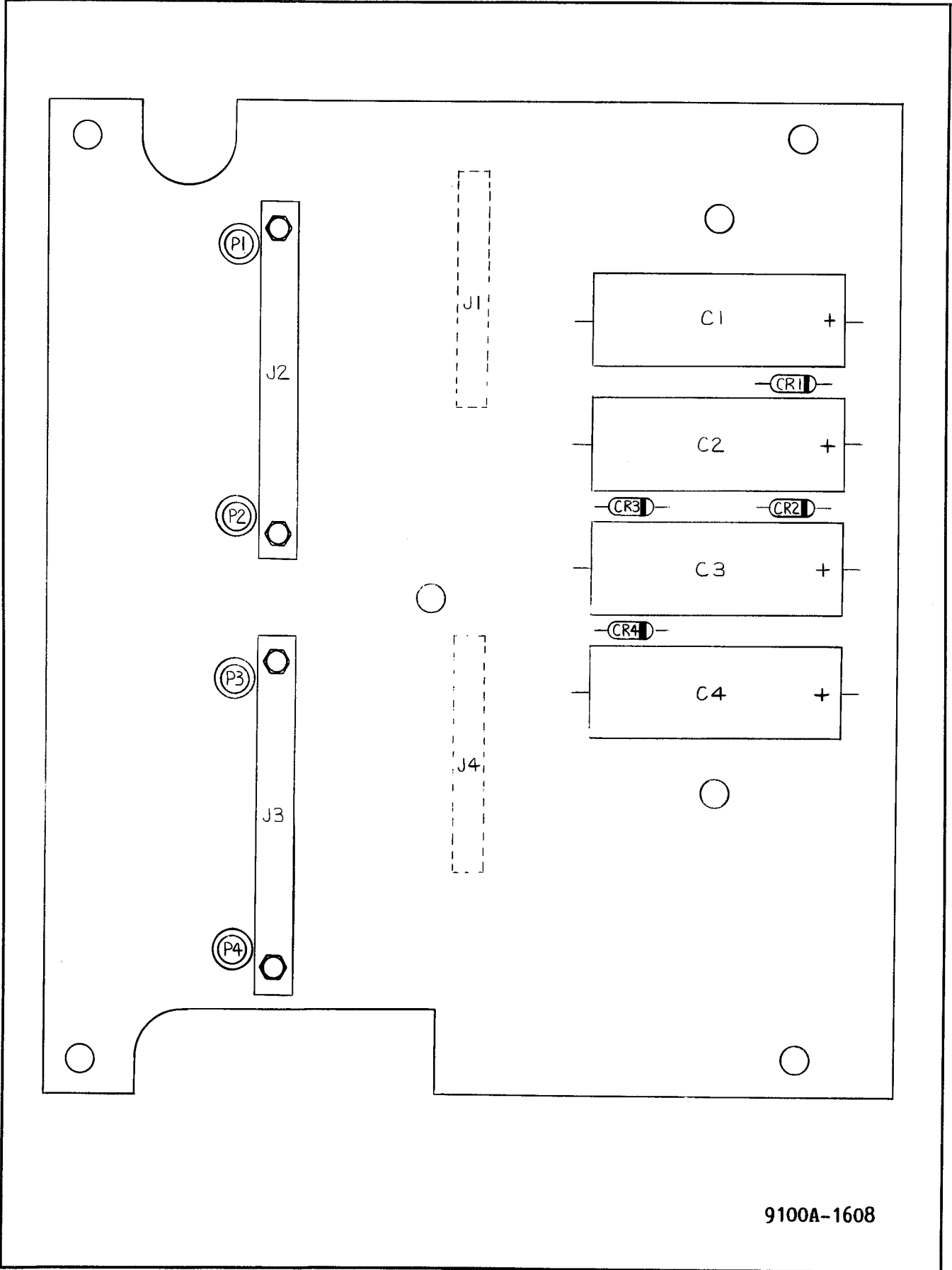

9100A-1608

Figure 5-8. A8 I/O Module (Top) PCA

5/List of Replaceable Parts

Table 5-10. A9 Probe I/O Interface PCA
(See Figure 5-9.)

REFERENCE DESIGNATOR	FLUKE STOCK	MFRS SPLY	MANUFACTURERS PART NUMBER	TOT QTY	R S T	N O E
-A>-NUMERIC--> S-----DESCRIPTION-----	--NO--	-CODE-	-OR GENERIC TYPE-----	QTY-	-Q	-E-
C 1, 3, 4,	747287	89536	747287	23		
C 8- 11, 16,	747287					
C 17, 19, 21,	747287					
C 23, 25- 33,	747287					
C 39, 40	747287					
C 2	714618	89536	714618	1		
C 5, 7, 20,	772491	89536	772491	6		
C 22, 24, 35	772491					
C 6, 14, 18	780478	89536	780478	3		
C 12	769778	89536	769778	1		
C 13	769240	89536	769240	1		
C 15	747279	89536	747279	1		
C 34	781203	89536	781203	1		
C 36	747360	89536	747360	1		
C 37, 38	747261	89536	747261	2		
C 41, 42	348516	56289	196D476X0020TE4	2		
CR 1- 6, 8,	742064	89536	742064	8	1	
CR 11	742064					
CR 7, 9, 10	742320	89536	742320	3	2	
CR 12	782573	89536	782573	1	1	
F 1	109314	71400	AGC1-4	1	5	
F 1	543504	71400	GMA1-4	1	5	
J 1	782169	89536	782169	1		
J 2	782094	89536	782094	1		
J 3	782151	89536	782151	1		
J 4	714154	89536	714154	1		
J 5	782086	89536	782086	1		
J 6, 7	603670	89536	603670	2		
MP 1	460238	61935	031.1666	1		
MP 1	461020	89536	461020	1		
Q 1	478370	89536	478370	1	1	
Q 2, 6, 7,	742023	89536	742023	4	1	
Q 9	742023					
Q 3, 4, 5,	742031	89536	742031	4	1	
Q 8	742031					
Q 10, 11	325761	09214	D44C5	2	1	
R 1	746248	89536	746248	1		
R 2	746537	89536	746537	1		
R 3- 6, 48,	746370	89536	746370	6		
R 49	746370					
R 7	746313	89536	746313	1		
R 8	769810	89536	769810	1		
R 9	746230	89536	746230	1		
R 10- 12, 14,	740506	89536	740506	6		
R 21, 28	740506					
R 13, 15	746339	89536	746339	2		
R 16, 46, 51,	769869	89536	769869	4		
R 59	769869					
R 17, 20, 26,	745992	89536	745992	8		
R 31, 36, 41,	745992					
R 54, 78	745992					
R 18, 22, 23,	740522	89536	740522	23		
R 27, 32- 34,	740522					
R 37, 38, 42,	740522					
R 52, 53, 55,	740522					
R 56, 58, 61-	740522					
R 63, 67, 72,	740522					
R 80, 82, 86	740522					
R 19, 35, 84,	746685	89536	746685	4		
R 85	746685					
R 24, 29, 30	746602	89536	746602	3		
R 25	746545	89536	746545	1		
R 39	746792	89536	746792	1		
R 40, 43, 45,	746297	89536	746297	6		
R 47, 79, 81	746297					
R 44	746768	89536	746768	1		
R 50, 57	780981	89536	780981	2		
R 60	783266	89536	783266	1		
R 64	746404	89536	746404	1		
R 65	746677	89536	746677	1		

An * in 'S' column indicates a static-sensitive part.

5/List of Replaceable Parts

Table 5-10. A9 Probe I/O Interface PCA (cont.)

REFERENCE DESIGNATOR	FLUKE STOCK	MFRS SPLY	MANUFACTURERS PART NUMBER	TOT QTY	R S T	N O E
-A>-NUMERIC--> S-----DESCRIPTION-----	--NO--	-CODE-	-OR GENERIC TYPE-----	QTY-	-Q	-E-
R 68, 75	801258	89536	801258	2		
R 69	746263	89536	746263	1		
R 70	769844	89536	769844	1		
R 71, 74, 76,	769794	89536	769794	4		
R 77	769794					
R 73	745984	89536	745984	1		
R 83	354944	80031	CR251-4-5P2E2	1	1	
R 87	780999	89536	780999	1		
R 88	810606	89536	810606	1	1	
R 90	746230	89536	746230	1		
TP 1- 7	781237	89536	781237	7		
U 1	742817	89536	742817	1	1	
U 2	742171	89536	742171	1	1	
U 3	741025	89536	741025	1	1	
U 4, 12	742148	89536	742148	2	1	
U 5	780957	89536	780957	1	1	
U 6	780965	89536	780965	1	1	
U 7, 13	740878	89536	740878	2	1	
U 8	740951	89536	740951	1	1	
U 9	773028	89536	773028	1	1	
U 10	742163	89536	742163	1	1	
U 11	743237	89536	743237	1	1	
U 14, 15	742122	89536	742122	2	1	
U 16	772806	89536	772806	1	1	
U 17	742619	89536	742619	1	1	
U 18	741546	89536	741546	1	1	
U 19	741553	89536	741553	1	1	
U 20, 23	743112	89536	743112	2	1	
U 21, 22	782243	89536	782243	2	1	
U 24, 37	741561	89536	741561	2	1	
U 25	740977	89536	740977	1	1	
U 26, 32, 33	742114	89536	742114	3	1	
U 27	740985	89536	740985	1	1	
U 28, 29	801274	89536	801274	2	1	
U 30	782219	89536	782219	1	1	
U 31	801399	89536	801399	1	1	
U 34	782235	89536	782235	1	1	
U 35, 36, 39	781195	89536	781195	3	1	
U 38	742155	89536	742155	1	1	
U 40	429910	07263	uA78L05AWC	1	1	
U 41	742569	89536	742569	1	1	
XF 1	602763	89536	602763	1		

An * in 'S' column indicates a static-sensitive part.

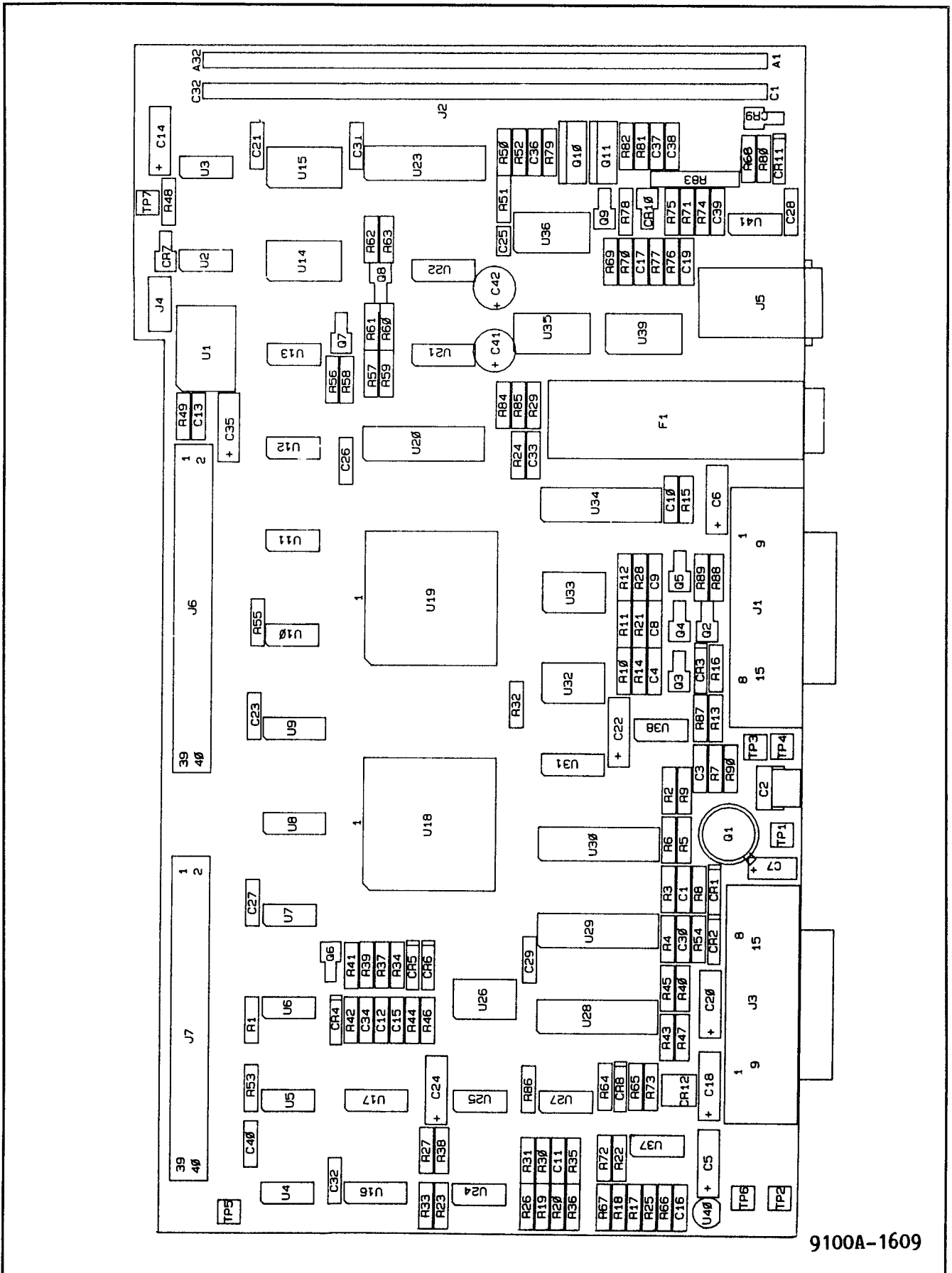

9100A-1609

Figure 5-9. A9 Probe I/O Interface PCA

5/List of Replaceable Parts

Table 5-11. A10 Multi-Function Interface PCA
(See Figure 5-10.)

REFERENCE DESIGNATOR	FLUKE STOCK	MFRS SPLY	MANUFACTURERS PART NUMBER	TOT QTY	R S T	N O T
-A>-NUMERICS-->	--NO--	-CODE-	--OR GENERIC TYPE----	QTY-	-Q	-E-
B 1	782953	89536	782953	1	1	
C 1, 2	369074	89536	369074	2	1	
C 3, 10- 21	407361	72982	8121-A100-W5R-103M	13		
CR 1	203323	07910	1N4448	1	1	
H 1	183574	89536	183574	2		
H 2	423616	89536	423616	2		
J 1	747816	89536	747816	1		
J 2	783464	89536	783464	1		
J 3	782201	89536	782201	1		
MP 1	768663	89536	768663	1		
Q 1	195974	64713	2N3906	1	1	
Q 2	218396	04713	2N3904	1	1	
R 1- 3, 6,	348839	80031	CR251-4-5P10K	7		
R 7, 9, 12	348839					
R 4	221986	01121	CB2265	1		
R 5	376434	80031	CR251-4-5P51K	1		
R 8, 10	441485	80031	CR251-4-5P200K	2		
RN 1, 2	769356	89536	769356	2		
RN 3, 4	769364	89536	769364	2		
RN 5	414003	80031	95081002CL	1		
TP 1- 3	781237	89536	781237	3		
U 2	742858	89536	742858	1	1	
U 3	818211	89536	818211	1	1	
U 9	604181	12040	MM58167N	1	1	
U 10	408732	01295	SN74LS164N	1	1	
U 11	799924	89536	799924	1	1	
U 12	741280	89536	741280	1	1	
XU 2	429282	09922	D1LB40P-108	1		
XU 3	643999	89536	643999	1		
XU 9	376236	91506	324-AG39D	1		
Y 1	501817	89536	501817	1	1	

An * in 'S' column indicates a static-sensitive part.

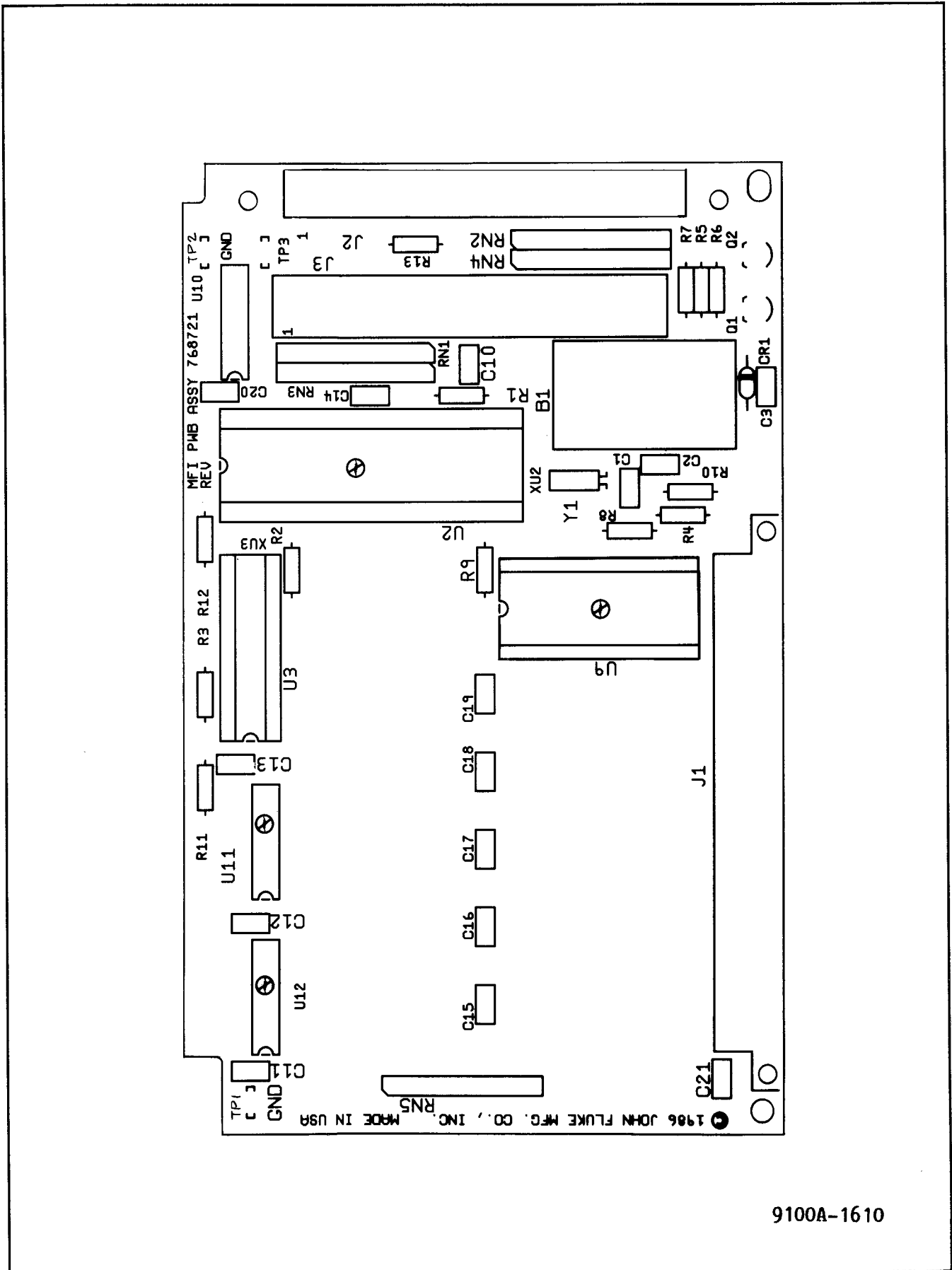

Figure 5-10. A10 Multi-Function Interface PCA

5/List of Replaceable Parts

Table 5-12. All I/O Connector PCA
(See Figure 5-11.)

REFERENCE DESIGNATOR		FLUKE STOCK	MFRS SPLY	MANUFACTURERS PART NUMBER	TOT QTY	R S	O T	N E
-A>-NUMERICS-->	S-----DESCRIPTION-----	--NO--	-CODE-	-OR GENERIC TYPE-----		-Q-	-E-	
C 1, 17	CAP, AL, 1000UF, +50-20%, 35V	641217	57640	SM/VB	2			
C 2- 15	CAP, CER, 0.01UF, +-20%, 100V, X7R	407361	72982	8121-A100-W5R-103M	14	1		
C 16	CAP, AL, 10000UF, +-20%, 6.3V, SOLV PROOF	800045	89536	800045	1			
CR 1, 2	* DIODE, SI, 100 PIV, 1.0 AMP	343491	01295	1N4002	2		1	
H 1	SCREW, MACH, PH, P, STL, 6-32X0.250	152140	89536	152140	2			
H 2	SCREW, THD CUT, PH, S, STL, 4-24X3/8	183574	89536	183574	2			
J 1	CONN, DIN41612, TYPE R, RT ANG, 64 SCKT	782102	89536	782102	1			
J 2- 5	CONN, D-SUB, PWB, 37 SCKT	782177	89536	782177	4			
MP 1	HEAT DISSIPATOR, 1.000, FOR TO-66	799965	89536	799965	1			
R 1	RES, CF, 10K, +-5%, 0.25W	348839	80031	CR251-4-5P10K	1			
R 3	RES, WW, 0.47, +-5%, 2W	219360	89536	219360	1		1	
R 4	RES, MF, 243, +-0.1%, 0.125W, 50PPM	512228	89536	512228	1			
R 5	RES, MF, 732, +-1%, 0.125W, 100PPM	294884	89536	294884	1			
TP 1	TERM, UNINSUL, WIRE FORM, TEST POINT	781237	89536	781237	1			
U 1, 2	* IC, ECL, QUAD TTL-ECL TRANSLATOR	801266	89536	801266	2		1	
U 3	* IC, LSTTL, DUAL 4 INPUT NAND GATE	393280	01295	SN74LS20N	1		1	
U 4	* IC, VOLT REG, ADJ, 1.2 TO 32 V, 5 AMP OUT	585497	12040	LM338K	1		1	
Z 1, 3	RES, NET, SIP, 10PIN, 9RES, 330, +-2%	769364	89536	769364	2			
Z 2	RES, NET, SIP, 10PIN, 9RES, 4.7K, +-2%	484063	80031	95081002CL	1			

An * in 'S' column indicates a static-sensitive part.

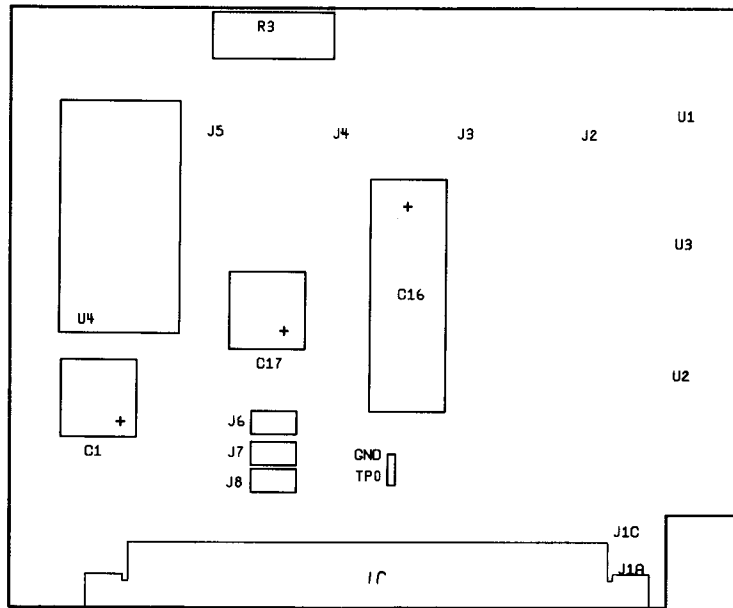

CKT 1 SIDE

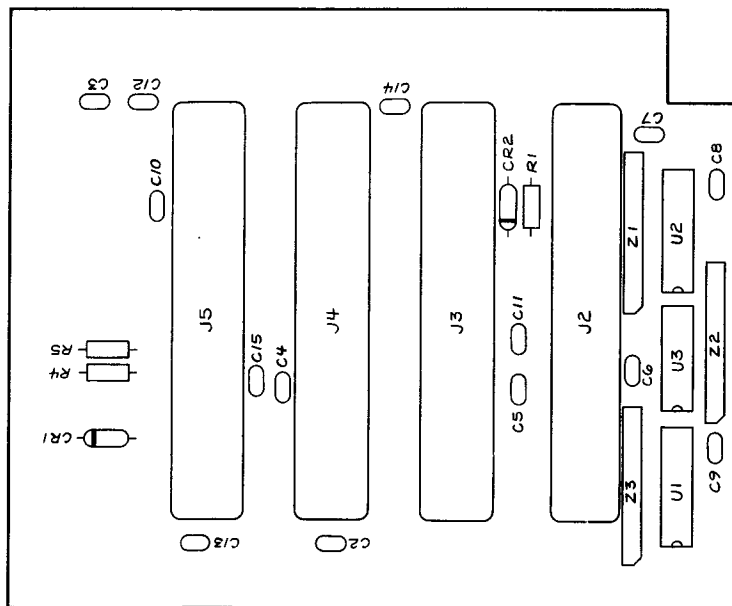

CKT 4 SIDE

9100A-1611

Figure 5-11. A11 I/O Connector PCA

5/List of Replaceable Parts

Table 5-13. A12 Half-Width Clip Modules

REFERENCE DESIGNATOR	FLUKE STOCK	MFRS SPLY	MANUFACTURERS PART NUMBER	TOT QTY	R S	O T	N E
-A>-NUMERICS-----> S-----DESCRIPTION-----	--NO--	-CODE-	-OR GENERIC TYPE-----				
C 1	597575	89536	597575	1			
C 2	407361	72982	8121-A100-W5R-103M	1			
H 1	800656	89536	800656	4			
J 1	800680	89536	800680	1	1		
J 2, 3		89536	CONNECTOR ASSY	2			1
MP 1		89536	CLIP, TEST, IC	1	2		1
MP 2	757500	89536	757500	1	2		
MP 3	773895	89536	773895	1			
MP 4	768697	89536	768697	1			
MP 5	774034	89536	774034	1			
MP 6		89536	KEY	2			1
MP 7		89536	MODULE DECAL	1			1
P 1, 2	800698	89536	800698	2			
S 1	782433	89536	782433	1	1		
S 2	408559	00779	435166-2	1			
W 1		89536	CABLE SET ASSY	1			1
W 2	801704	89536	801704	1	1		

An * in 'S' column indicates a static-sensitive part.

NOTES:

1 - Refer to the table below for appropriate part numbers for each type of Clip Module:

	MODULE								
	-14D	-14S	-16D	-16S	-18D	-20D	-20S	-24D	-24S
MP1	800052	817429	800060	817437	800078	800086	817445	800094	817478
W1	801639	801639	801647	801647	801654	801662	801662	801670	801670
J2,3	801878	801878	801886	801886	801894	801902	801902	801910	801910
MP6	-	-	-	-	773952	773952	773952	767954	767954
MP7	802140	819631	802157	819649	802165	802173	819656	802181	819664

5/List of Replaceable Parts

Table 5-14. A13 Full-Width Clip Modules

REFERENCE DESIGNATOR	FLUKE STOCK	MFRS SPLY	MANUFACTURERS PART NUMBER	TOT	R	N
-A>-NUMERICS-----> S-----DESCRIPTION-----	--NO--	-CODE-	-OR GENERIC TYPE-----	QTY-	-Q	-E-
C 1, 4	407361	72982	8121-A100-W5R-103M	2		
C 2, 3	597575	89536	597575	2		
H 1	800656	89536	800656	4		
J 1, 2	800680	89536	800680	2	1	
J 3, 4		89536		2		1
MP 1		89536		1	2	1
MP 2	757500	89536	757500	1	2	
MP 3	773895	89536	773895	1		
MP 4	802132	89536	802132	1		
MP 5	802124	89536	802124	1		
MP 6	767954	89536	767954	2		
MP 7		89536		1		1
P 1- 4	800698	89536	800698	2		
S 1	782433	89536	782433	1	1	
S 2	414490	00779	435166-5	1		
W 1		89536		1		1
W 2	801704	89536	801704	1	1	

An * in 'S' column indicates a static-sensitive part.

NOTES:

1 = Refer to the table below for appropriate part numbers for each type of Clip Module:

	MODULE		
	-28D	-28S	-40D
MP1	800102	821975	800110
W1	801688	801688	801696
J3, 4	801928	801928	801936
MP7	802199	819672	802207

5/List of Replaceable Parts

Table 5-15. A14 Calibration Module

REFERENCE DESIGNATOR		FLUKE STOCK	MFRS SPLY	MANUFACTURERS PART NUMBER	TOT	R S	O T
-A>-NUMERICS----->	S-----DESCRIPTION-----	--NO--	-CODE-	--OR GENERIC TYPE-----	QTY-	-Q-	-E-
H 1	SCREW, MACH, PHP, STL, 4-40 X 5/8	800656	89536	800656	7		
J 1, 2	CONN, RECT, PWB, PLUG, 33 POS	800680	89536	800680	2	1	
MP 2	TEST LEAD, CLIP-TO-CLIP, BLK, 20AWG	801050	89536	801050	1	1	
MP 3	CABLE TIE, 4"L, 0.100"W, 0.75 DIA	172080	89536	172080	2		
MP 4	BUTTON, SWITCH	773895	89536	773895	1		
MP 5	MODULE BOTTOM, DOUBLE	802132	89536	802132	1		
MP 6	MODULE TOP, DOUBLE	802124	89536	802124	1		
MP 7	KEY, EXTENDED	767954	89536	767954	2		
MP 8	MODULE DECAL, CALIBRATION	802223	89536	802223	1		
P 1- 4	BANANA PLUG, PWB, SOLDER OR SWAGE TYPE	800698	89536	800698	2		
S 1	SWITCH, PUSHBUTTON, SPST, MOMENTARY	782433	89536	782433	1	1	

An * in 'S' column indicates a static-sensitive part.

5/List of Replaceable Parts

Table 5-16. A15 Flying Lead Module

REFERENCE DESIGNATOR		FLUKE STOCK	MFRS SPLY	MANUFACTURERS PART NUMBER	TOT	N R O S T
-A>-NUMERICS-->	S-----	DESCRIPTION-----	--NO--	-CODE-	-OR GENERIC TYPE-----	QTY- --Q--E-
C	1	CAP,CER,0.1UF,+20%,50V,Z5U	597575	89536	597575	1
C	2	CAP,CER,0.01UF,+20%,100V,X7R	407361	72982	8121-A100-W5R-103M	1
H	1	SCREW, MACH, PHP, STL, 4-40 X 5/8	800656	89536	800656	4
J	1	CONN,RECT,PWB,PLUG,33 POS	800680	89536	800680	1 1
MP	1	BUTTON, SWITCH	773895	89536	773895	1
MP	2	MODULE BOTTOM, SINGLE	768697	89536	768697	1
MP	3	MODULE TOP, SINGLE	774034	89536	774034	1
MP	4	KEY	773952	89536	773952	2
MP	5	MODULE DECAL	802215	89536	802215	1
MP	6	CLIP, HOOK	757500	89536	757500	25 10
P	1, 2	BANANA PLUG,PWB,SOLDER OR SWAGE TYPE	800698	89536	800698	2
S	1	SWITCH,PUSHBUTTON,SPST,MOMENTARY	782433	89536	782433	1 1
S	2	SWITCH,DIP,SPST,4 POS	408559	00779	435166-2	1
W	1	CABLE ASSY, 10 PAIR, POS 1-10	801712	89536	801712	1
W	2	CABLE ASSY, 10 PAIR, POS 1-10	801720	89536	801720	1

An * in 'S' column indicates a static-sensitive part.

5/List of Replaceable Parts

Table 5-17. A16 512K RAM Module
(See Figure 5-12.)

REFERENCE DESIGNATOR	FLUKE STOCK	MFRS SPLY	MANUFACTURERS PART NUMBER	TOT QTY	R S	O T			
-A>-NUMERICS-->	S-----	DESCRIPTION-----	--NO--	-CODE-	-OR GENERIC TYPE-----	-Q -E-			
C 1- 22			CAP,CER,0.1UF,+/-10%,25V,X7R,1206	747287	89536	747287	22		
C 23			CAP,CER,47PF,+/-10%,50V,COG,1206	747352	89536	747352	1		
U 1- 9, 11-	*		IC, NMOS, 256K X 1 DRAM, 120NSEC, PLC	808212	89536	808212	18	1	
U 19	*			808212					
U 10	*		IC,ALSTTL,OCTAL BUS TRANSCEIVER,SOIC	799593	89536	799593	1	1	
U 20	*		IC,ALSTTL,QUAD 2 INPUT NAND GATE,SOIC	782268	89536	782268	1	1	
U 21	*		IC,ALSTTL,QUAD 2 INPUT OR GATE,SOIC	742460	89536	742460	1	1	
U 22	*		IC,ALSTTL,DUAL JK F/F,-EDG TRG,SOIC	807578	89536	807578	1	1	

An * in 'S' column indicates a static-sensitive part.

NOTE

The 9105A-007 uses two A16 512K RAM Modules.

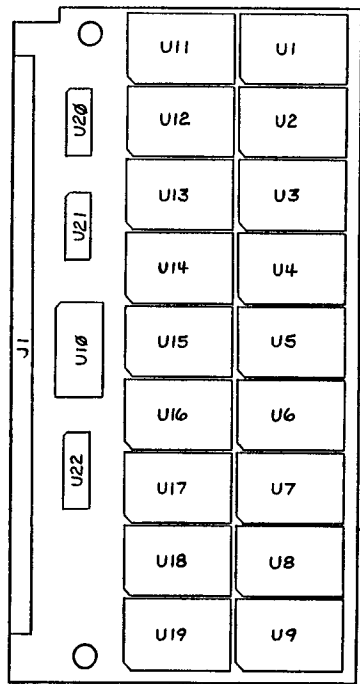

CKT 4

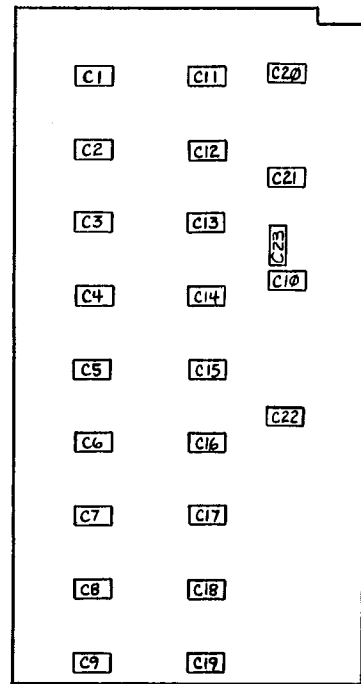

CKT 1

9100A-1616

Figure 5-12. A16 512K RAM Module

5/List of Replaceable Parts

Table 5-18. A19 Monochrome Monitor

REFERENCE DESIGNATOR	FLUKE STOCK	MFRS SPLY	MANUFACTURERS PART NUMBER	TOT QTY	R S T	N O T
-A>-NUMERICS----- S	-----DESCRIPTION-----	NO--	-CODE-	-OR GENERIC TYPE-----	QTY-	-Q -E-
BT 1	POWER SUP, 40W, +5@3.5A, +12@2A, -12@1A	769406	89536	769406	1	
H 1	SCREW, MACH, PH, P, STL, 10-32X0.375	114314	73734	19084	4	
H 2	WASHER, FLAT, STEEL, 0.203X0.434X0.031	110262	89536	110262	3	
H 3	WASHER, FLAT, STL, .149, .375, .031	110270	89536	110270	8	
H 4	SCREW, MACH, PH, P, STL, 6-32X0.375	152165	89536	152165	8	
H 5	SCREW, MACH, SEMS, PH, P, STL, 6-32X0.375	177022	89536	177022	3	
H 6	SCREW, MACH, SEMS, PH, P, STL, 6-32X0.375	177022	89536	177022	5	
H 7	SCREW, MACH, PH, SEMS, STL, 4-40X1/4	185918	89536	185918	6	
H 8	CONN ACC, D-SUB, LATCH BLOCK, SHORT, 4-40	783480	89536	783480	2	
H 9	SCREW, MACH, PH, P, STL, 6-32X1.000	114215	89536	114215	3	
H 10	WASHER, FLAT, STL, .149, .375, .031	110270	89536	110270	3	
H 11	SCREW, MACH, SEMS, PH, P, STL, 6-32X0.375	177022	89536	177022	4	
MP 1	BRACKET, CRT, FINISHED	794149	89536	794149	4	1
MP 2	LABEL, BAR-CODE, 9.4 CPI, 0.245X1.25	807099	89536	807099	2	
MP 3	CHASSIS, FINISHED	794156	89536	794156	1	
MP 4	SPACER, PWB, NYL, .312	780619	89536	780619	3	
MP 5	BEZEL ASSY, 9100	792903	89536	792903	1	
MP 6	GASKET, TOUCH PANEL, DUST	843250	89536	843250	1	
MP 7	NAMEPLATE	787275	89536	787275	1	
MP 8	COVER, CHASSIS, 9100, FINISHED	794198	89536	794198	1	
MP 9	DAMPER, VIBRATION	805085	89536	805085	4	
MP 10	CABLE TIE ANCHOR, ADHSV, 0.160" TIE	407908	89536	407908	5	
MP 11	CABLE TIE, 4"L, 0.100"W, 0.75 DIA	172080	89536	172080	8	
MP 12	DECAL, COVER, 9100	792911	89536	792911	1	
MP 13	DECAL, FAN PANEL	785493	89536	785493	1	
MP 14	BRACKET, POT MOUNTING, FINISHED	794131	89536	794131	1	
MP 15	THUMBWHEEL, POTENTIOMETER	787358	89536	787358	1	
MP 16	SHIPPING BOX	776435	89536	776435	1	
MP 17	SHIPPING INSERT	777045	89536	777045	1	
MP 18	OPTION TRAY	801613	89536	801613	1	
MP 19	SHIPPING CARRIER/INSERT	777052	89536	777052	1	
MP 20	INSERT, OPTION TRAY	809616	89536	809616	1	
MP 21	ENCLOSURE W/GRILLS	802454	89536	802454	1	
MP 22	COVER, FAN	787366	89536	787366	1	
MP 23	DECAL, CAUTION	787242	89536	787242	1	
MP 24	BASE	747972	89536	747972	1	
MP 25	RETAINER, NUT	749655	89536	749655	1	
MP 26	BUSHING COVER RF OUTPUT	802553	89536	802553	1	
MP 27	SHOULDER WASHER	792861	89536	792861	2	
MP 28	RETAINER PIN	802520	89536	802520	1	
MP 29	BASE, MOUNTING PLATE	747998	89536	747998	1	
MP 30	FOOT, RUBBER, SELF-ADHESIVE, BLACK	513820	89536	513820	4	
MP 31	PIN, MECHANICAL, CLEVIS, 5/16 X 1-3/4	800524	89536	800524	1	
MP 32	SPRING, COIL, COMP, SQUARED END, M WIRE	800532	89536	800532	1	
MP 33	BUMPER, STEM, BUNA-S, 0.500X0.125	800839	89536	800839	4	
MP 34	ASSY, AC POWER PANEL	776377	89536	776377	1	
MP 35	DISPLAY, MONITOR GREEN	785444	89536	785444	1	
MP 36	CONTRAST OVERLAY	819987	89536	819987	0	1 1
W 1	CORD, LINE, 5-15/IEC, 3-18AWG, SVT	284174	89536	284174	1	
W 2	CABLE ASSY, 9100	778613	89536	778613	1	

An * in 'S' column indicates a static-sensitive part.

NOTE 1 = Contrast overlay is part of the bezel assembly.

5/List of Replaceable Parts

Table 5-19. Option -003 Parallel I/O Module
(See Figure 5-13.)

REFERENCE DESIGNATOR	FLUKE STOCK	MFRS SPLY	MANUFACTURERS PART NUMBER	TOT QTY	R S	O T	N E
-A>-NUMERICS-->	S-----DESCRIPTION-----	---NO--	-CODE-	-OR GENERIC TYPE-----			
A 7	* I/O MODULE (MAIN) PCA	768838	89536	768838	1		
A 8	* I/O MODULE (TOP) PCA	755611	89536	755611	1		
A 14	CALIBRATION MODULE	813980	89536	813980	1		
A 15	FLYING LEAD MODULE, 20 LEAD SET, TSTD	819763	89536	819763	1		
F 1	FUSE, 1/4 X 1-1/4, SLOW, 1.0A, 250V	109272	71400	MDL1A	1	5	
F 1	FUSE, 5X20MM, SLOW, 1A, 250V	808055	89536	808055	1	5	
H 1	SCREW, MACH, PHP, STL, 6-32 X 7/8	801241	89536	801241	4		
H 2	SCREW, MACH, PHP SEMS, STL, 6-32X1/4	178533	89536	178533	9		
MP 1	HLDR PART, FUSE, CAP, 1/4X1-1/4	460238	61935	031.1666	1		
MP 2	HLDR PART, FUSE, CAP, 5X20MM	461020	89536	461020	1		
MP 3	CASE TOP, I/O MODULE	773291	89536	773291	1		
MP 4	CASE BOTTOM, I/O MODULE	773283	89536	773283	1		
MP 5	DECAL, CASE TOP, I/O MODULE	805630	89536	805630	1		
MP 6	DECAL, CASE BOTTOM, I/O MODULE	773382	89536	773382	1		
MP 7	SHIELD, I/O MODULE	775866	89536	775866	1		
MP 8	FOOT, NON-SKID	774000	89536	774000	4		
MP 9	NAMEPLATE, SERIAL -REAR PANEL-	472795	89536	472795	1		
MP 10	CARTON KEYBOARD, I/O	805804	89536	805804	1		
MP 11	FOAM INSERT, KEYBOARD-I/O	805812	89536	805812	1		
MP 12	CONVOLUTED FOAM, KEYBOARD-I/O	805820	89536	805820	1		
W 1	CABLE ASSEMBLY, EXTERNAL EVENT	773945	89536	773945	1	1	
W 2	CABLE ASSY, I/O MODULE	783977	89536	783977	1		
W 3	WIRE, SHIELD CONTACT	803122	89536	803122	1		

An * in 'S' column indicates a static-sensitive part.

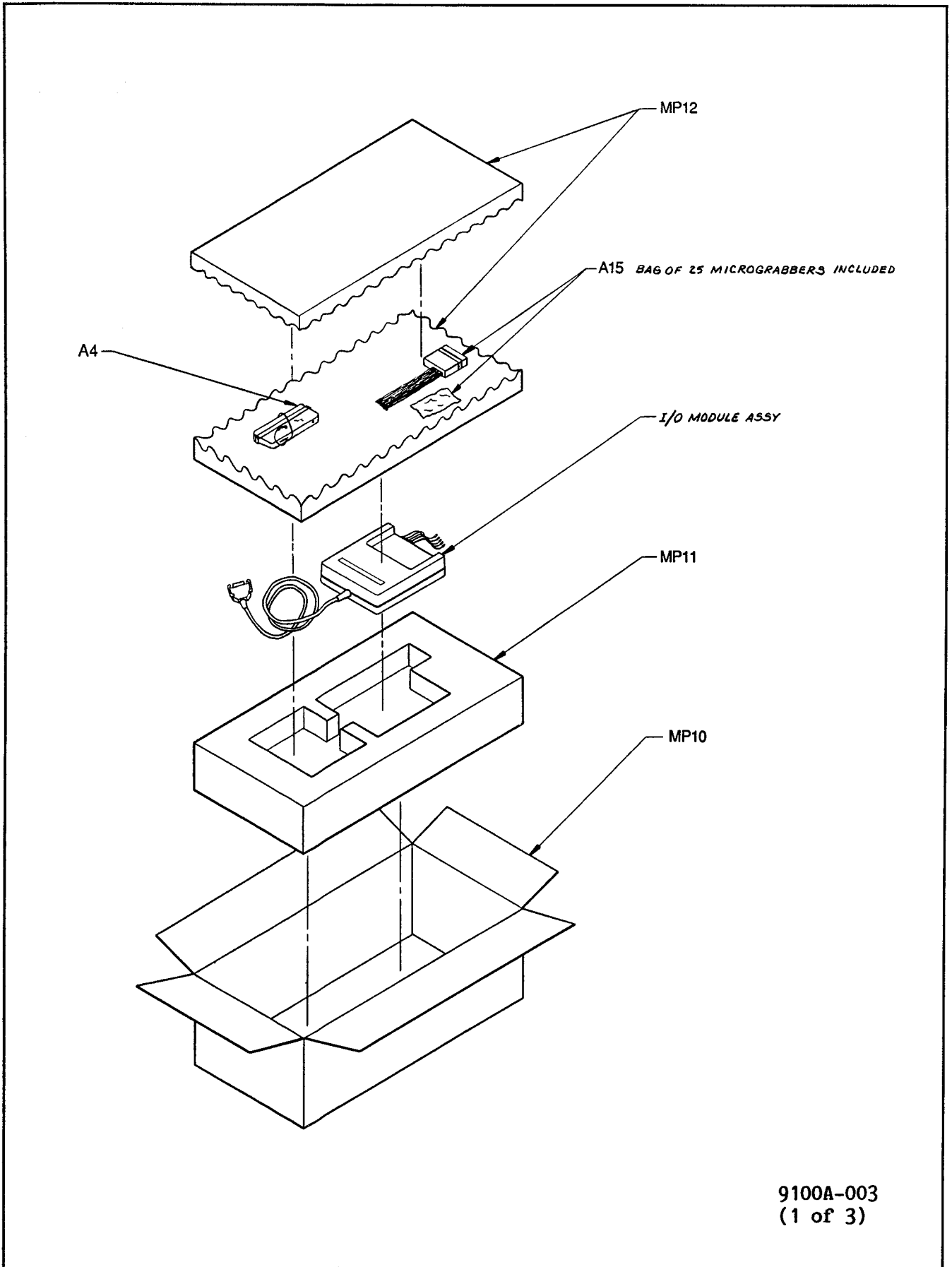

9100A-003
(1 of 3)

Figure 5-13. Option -003 Parallel I/O Module

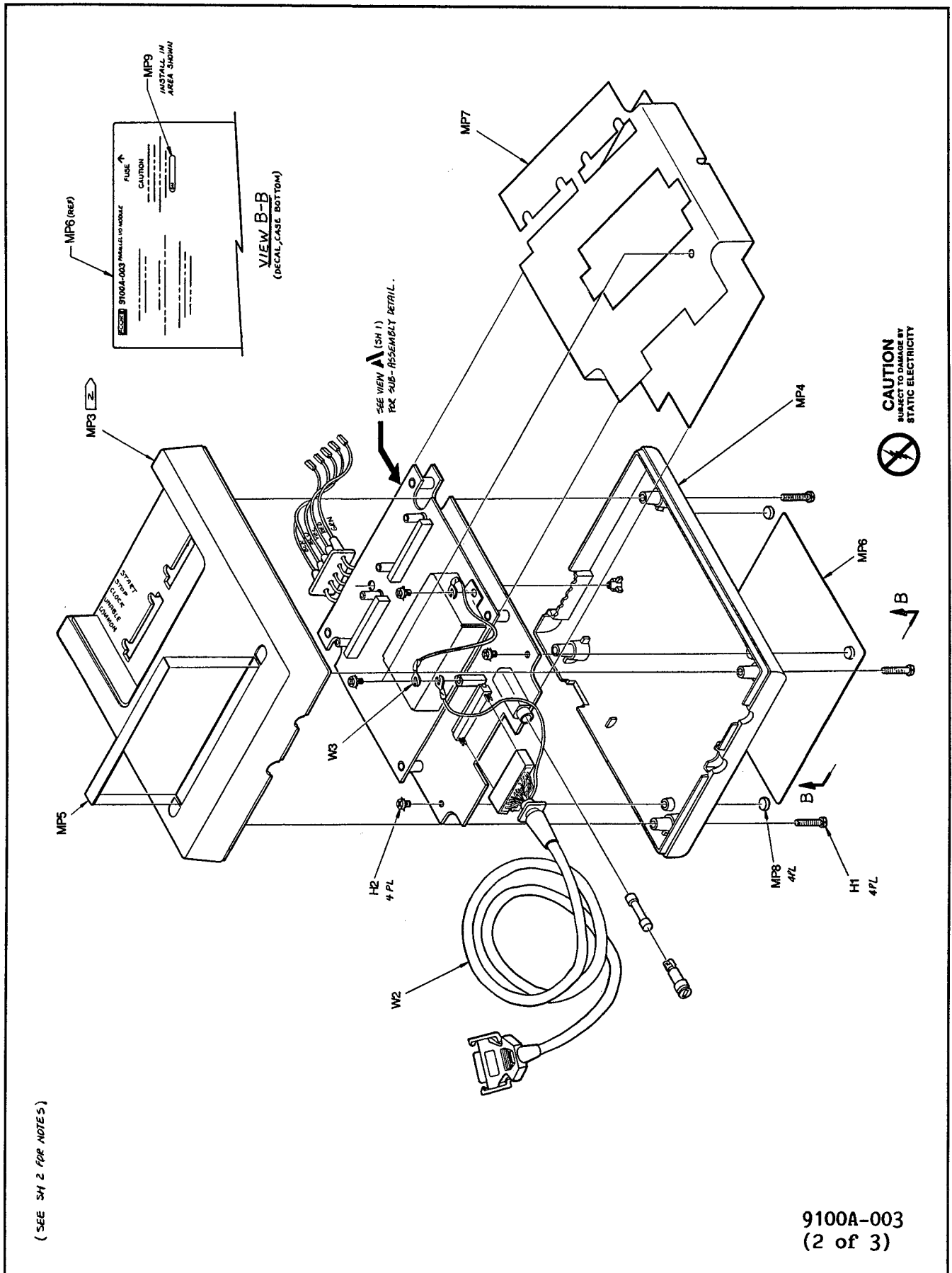
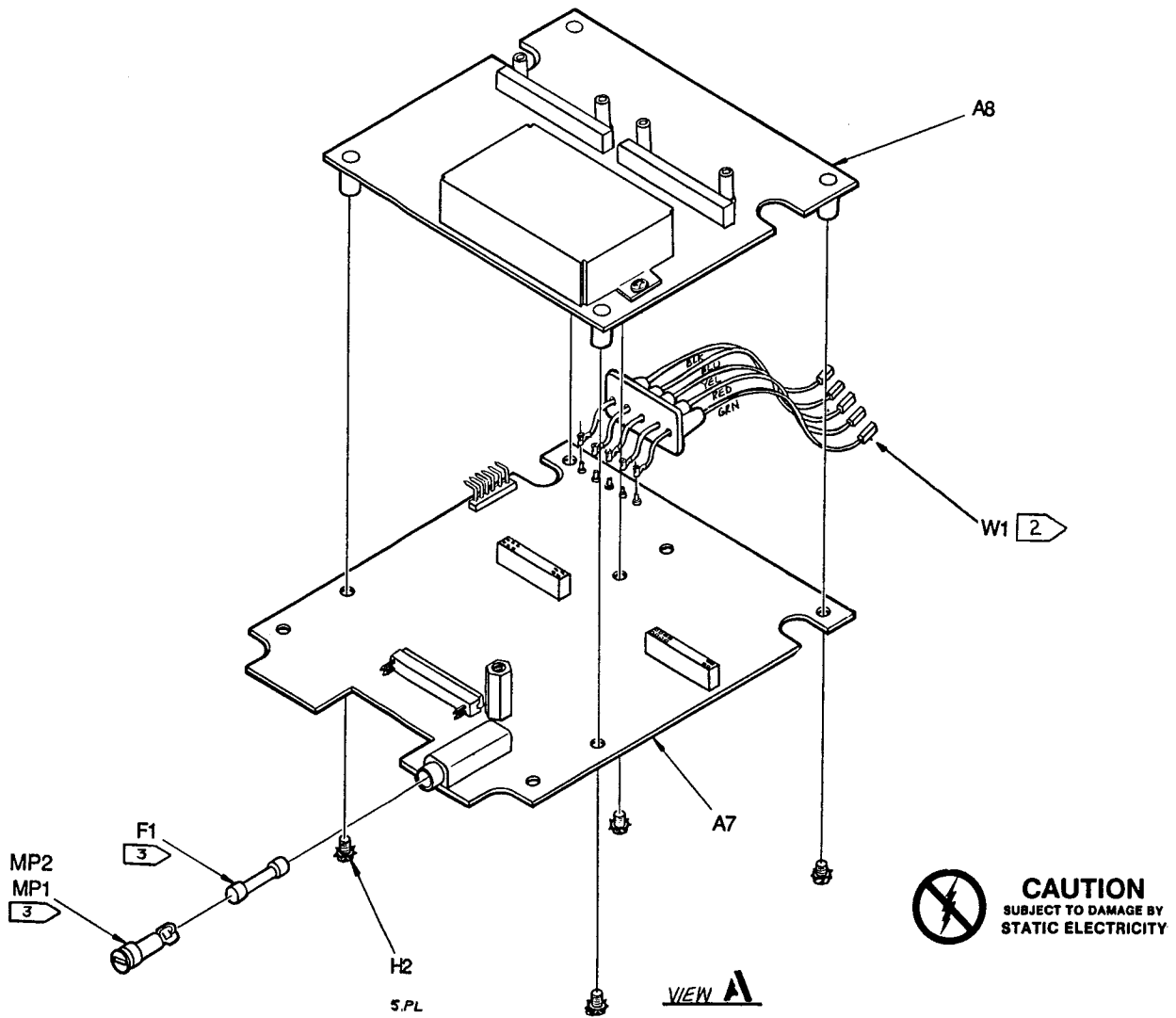

Figure 5-13. Option -003 Parallel I/O Module (cont.)



NOTES: UNLESS OTHERWISE SPECIFIED.

1. **WARNING:** Ⓢ INDICATES USAGE OF MOS DEVICE(S) WHICH MAY BE DAMAGED BY STATIC DISCHARGE. USE SPECIAL HANDLING PER S.O.P. 10.1

2. CABLE NOMENCLATURE ON MP3 CASE TOP SHALL MATCH UP WITH COLORS OF W1 AS NOTED:
 COMMON - BLACK WIRE
 UNABLE - BLUE WIRE
 CLOCK - YELLOW WIRE
 STOP - RED WIRE
 START - GREEN WIRE

3. FUSE & FUSE CAP VARY FOR DIFFERENT VOLTAGE CONFIGURATIONS; SEE FUSE CHART FOR FUSE & CAP PART NO.S.

FUSE CHART			3	CONFIGURATION
VOLTAGE	FUSE	CAP		
100/120V	109272	460238	115V	763649
220/240V	808055	461020	230V	763656

9100A-003
(3 of 3)

Figure 5-13. Option -003 Parallel I/O Module (cont.)

5/List of Replaceable Parts

Table 5-20. Option -004 Programmer's Station, Monochrome
(See Figure 5-14.)

REFERENCE DESIGNATOR	FLUKE STOCK	MFRS SPLY	MANUFACTURERS PART NUMBER	TOT QTY	R S	N O T
-A>-NUMERICS-->	S-----	DESCRIPTION-----	--NO-- -CODE- -OR GENERIC TYPE-----	QTY-	-Q	-E-
A 4	*	VIDEO CONTROLLER PCA	768762 89536 768762	1		
A 19		MONOCHROME MONITOR	826362 89536 826362	1		
A 103		KEYBOARD, ASYNC ASCII, 1200 BAUD	757120 89536 757120	1		1
H 1		RIVET, POP, DOME, AL, 0.125X0.316	423616 89536 423616	2		
MP 2		VIDEO CONNECTOR BRACKET	768648 89536 768648	1		
MP 3		NAMEPLATE, SERIAL -REAR PANEL-	472795 89536 472795	1		
MP 4		PROGRAMMER SOFTWARE SYSTEM, SLEEVED	89536	1		2
MP 5		CARTON KEYBOARD, I/O	805804 89536 805804	1		
MP 6		CONVOLUTED FOAM, KEYBOARD-I/O	805820 89536 805820	1		
MP 7		PROGRAM COPY PROTECTION SHEET	847066 89536 847066	1		
TM 1		9100A TL/1 REFERENCE MANUAL	818047 89536 818047	1		
TM 2		9100A PROGRAMMERS MANUAL	813857 89536 813857	1		
U 5	*	PROGRAMMED 27128-150	818195 89536 818195	1		
W 1		CABLE, MONITOR	787903 89536 787903	1		
Z 1		JUMPER, DIP, 0.300CTR, PROGRAM, 16 POS	783183 89536 783183	1		

An * in 'S' column indicates a static-sensitive part.

NOTES:

- 1 = See 9100A-013 option for replacement parts breakdown for A103.
- 2 = This software available only for 9100A's with Programmer's Station installed. Contact the factory if replacement is needed.

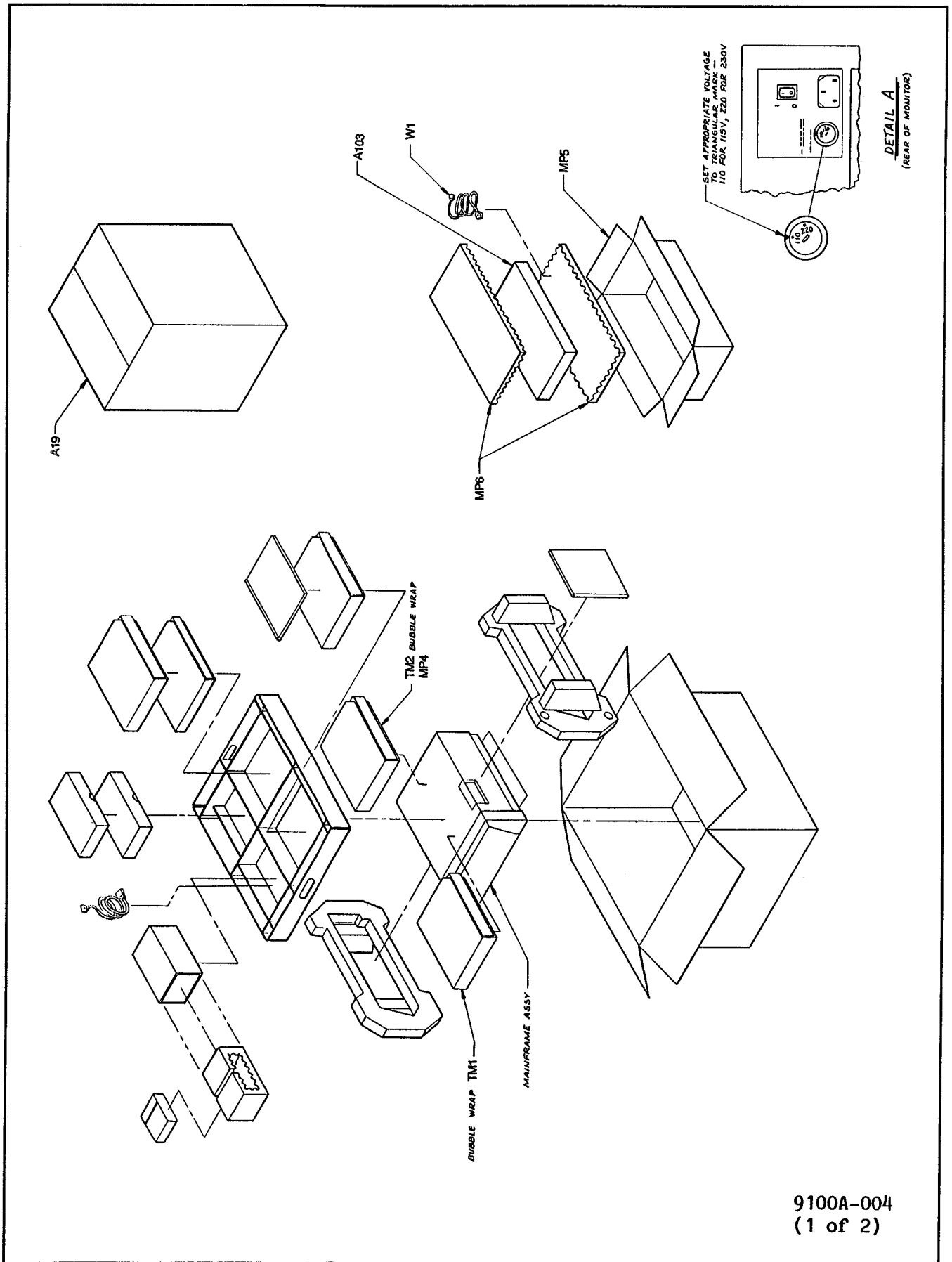

9100A-004
(1 of 2)

Figure 5-14. Option -004 Programmer's Station, Mono

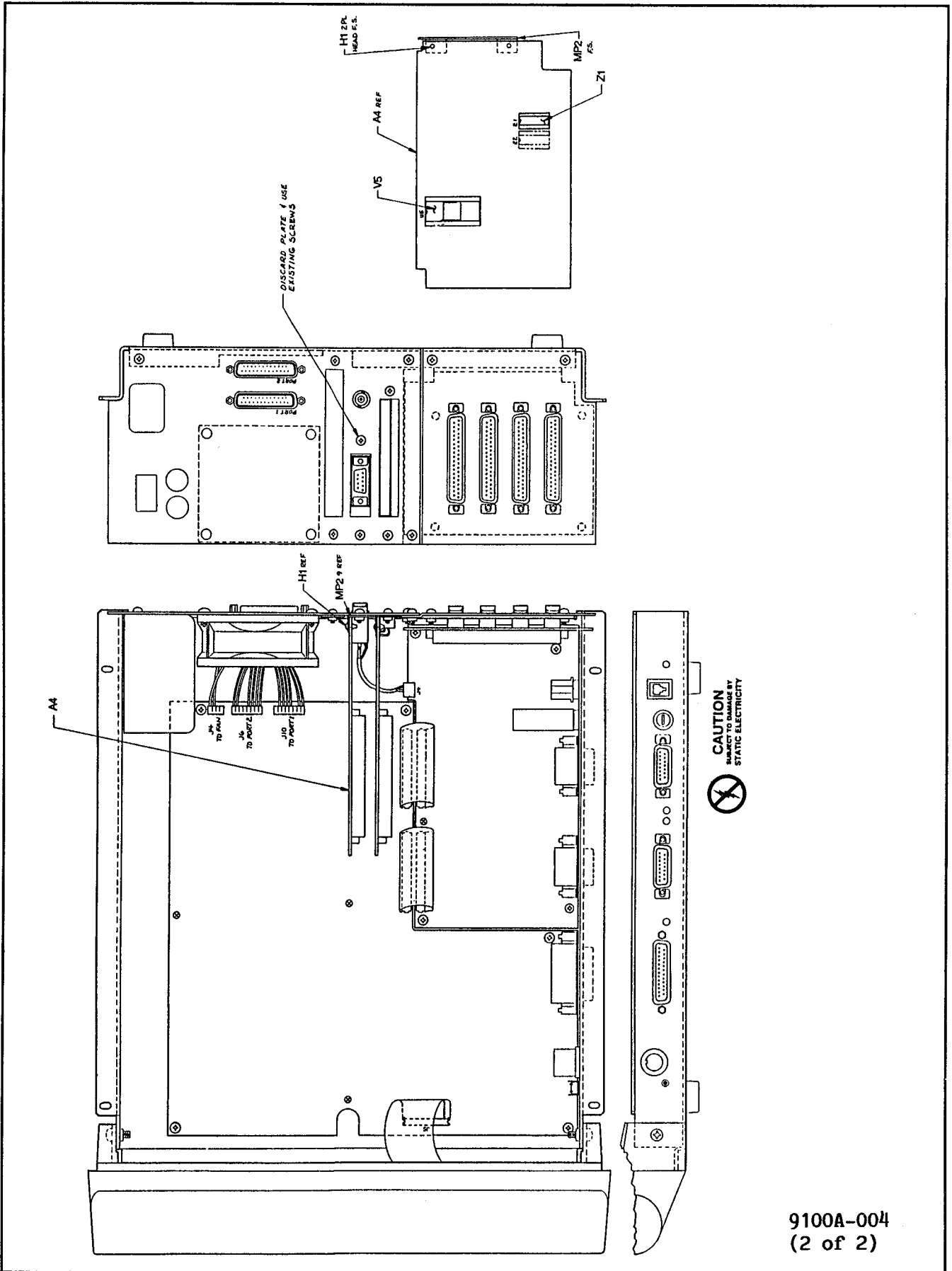

Figure 5-14. Option -004 Programmer's Station, Mono (cont.)

5/List of Replaceable Parts

Table 5-21. Option -005 Programmer's Station, Color
(See Figure 5-15.)

REFERENCE DESIGNATOR	FLUKE STOCK	MFRS PLY	MANUFACTURERS PART NUMBER	TOT	R S	N T
-A>-NUMERICS-----> S-----DESCRIPTION-----	--NO--	-CODE-	-OR GENERIC TYPE-----	QTY-	-Q	-E-
A 4	* VIDEO CONTROLLER PCA	768762	89536 768762	1		
A 103	KEYBOARD, ASYNC ASCII, 1200 BAUD	757120	89536 757120	1		1
H 1	RIVET, POP, DOME, STL, 0.250X0.720	187625	89536 187625	2		
MP 2	VIDEO CONNECTOR BRACKET	768648	89536 768648	1		
MP 3	PROGRAMMER SOFTWARE SYSTEM, SLEEVED		89536	1		2
MP 4	CARTON KEYBOARD, I/O	805804	89536 805804	1		
MP 5	CONVOLUTED FOAM, KEYBOARD-I/O	805820	89536 805820	1		
MP 6	PROGRAM COPY PROTECTION SHEET	847066	89536 847066	1		
TM 1	9100A TL/1 REFERENCE MANUAL	818047	89536 818047	1		
TM 2	9100A PROGRAMMERS MANUAL	813857	89536 813857	1		
U 5	* PROGRAMMED 27128-150	818195	89536 818195	1		
Z 2	JUMPER, DIP, 0.300CTR, PROGRAM, 16 POS	783183	89536 783183	1		

An * in 'S' column indicates a static-sensitive part.

NOTES:

1 = See 9100A-013 option for replacement parts breakdown for A103.

2 = This software available only for 9100A's with Programmer's Station installed. Contact the factory if replacement is needed.

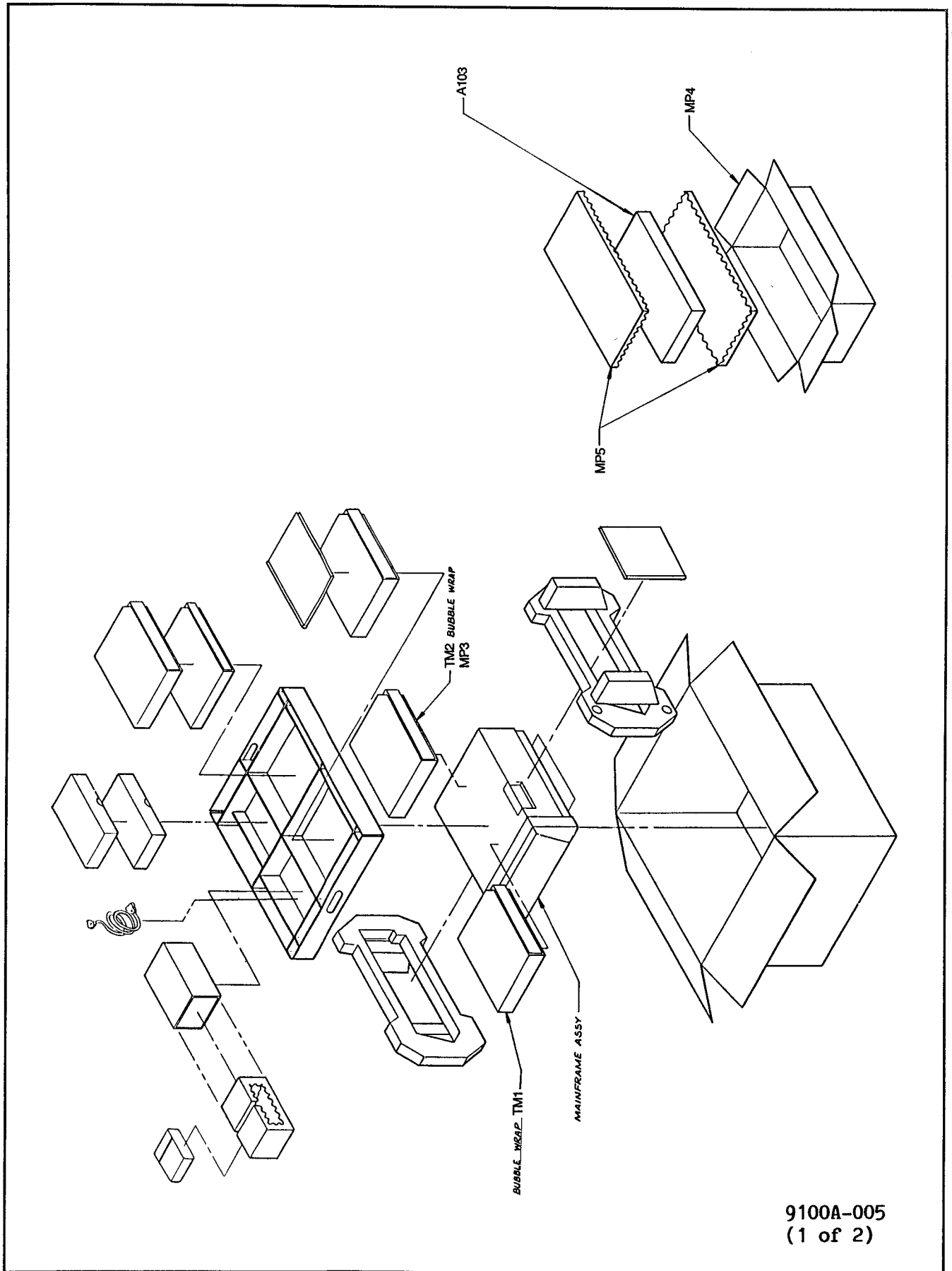

Figure 5-15. Option -005 Programmer's Station, Color

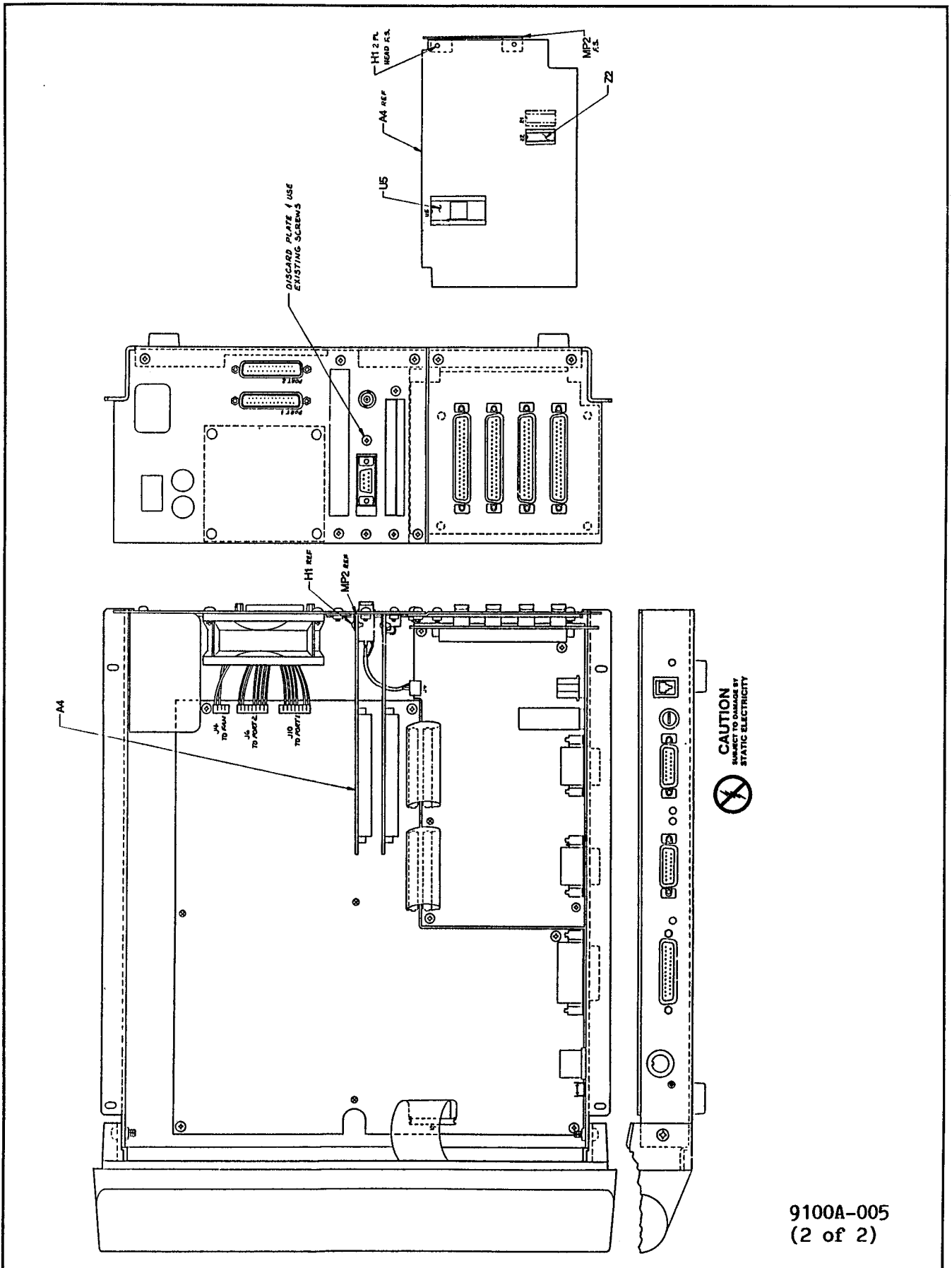

Figure 5-15. Option -005 Programmer's Station, Color (cont.)

9100A-005
(2 of 2)

5/List of Replaceable Parts

Table 5-22. Option -008 Real Time Clock PCA
(See Figure 5-16.)

REFERENCE DESIGNATOR	FLUKE STOCK	MFRS SPLY	MANUFACTURERS PART NUMBER	TOT	R	O
-A>-NUMERICS--> S-----DESCRIPTION-----	--NO--	-CODE-	-OR GENERIC TYPE----	QTY-	-Q	-E-
B 1	782953	89536	782953	1	1	
C 1, 2	369074	89536	369074	2	1	
C 3, 10- 21	407361	72982	8121-A100-W5R-103M	13		
CR 1	203323	07910	1N4448	1	1	
H 1	183574	89536	183574	2		
H 2	423616	89536	423616	2		
J 1	747816	89536	747816	1		
MP 1	802009	89536	802009	1		
Q 1	195974	64713	2N3906	1	1	
Q 2	218396	04713	2N3904	1	1	
R 1, 2, 6,	348839	80031	CR251-4-5P10K	6		
R 7, 9, 12	348839					
R 4	221986	01121	CB2265	1		
R 5	376434	80031	CR251-4-5P51K	1		
R 8, 10	441485	80031	CR251-4-5P200K	2		
R 11	340075	80031	CR251-4-5P10E	1		
RN 5	414003	80031	95081002CL	1		
TP 1- 3	781237	89536	781237	3		
U 3	818211	89536	818211	1	1	
U 9	604181	12040	MM58167N	1	1	
U 10	408732	01295	SN74LS164N	1	1	
U 11	799924	89536	799924	1	1	
U 12	741280	89536	741280	1	1	
XU 3	643999	89536	643999	1		
XU 9	376236	91506	324-AG39D	1		
Y 1	501817	89536	501817	1	1	

An * in 'S' column indicates a static-sensitive part.

5/List of Replaceable Parts

Table 5-23. Option -009 Video, Monochrome
(See Figure 5-17.)

REFERENCE DESIGNATOR	FLUKE STOCK	MFRS SPLY	MANUFACTURERS PART NUMBER	TOT QTY	R S	O T	N E
-A>-NUMERICS----->	S-----	DESCRIPTION-----	--NO-- -CODE- -OR GENERIC TYPE-----				
A 4	*	VIDEO CONTROLLER PCA	768762 89536 768762	1			
A 19		MONOCHROME MONITOR	826362 89536 826362	1			
H 1		RIVET, POP, DOME, AL, 0.125X0.316	423616 89536 423616	2			
MP 2		VIDEO CONNECTOR BRACKET	768648 89536 768648	1			
MP 3		NAMEPLATE, SERIAL -REAR PANEL-	472795 89536 472795	1			
U 5	*	PROGRAMMED 27128-150	818195 89536 818195	1			
W 1		CABLE, MONITOR	787903 89536 787903	1			
Z 1		JUMPER, DIP, 0.300CTR, PROGRAM, 16 POS	783183 89536 783183	1			

An * in 'S' column indicates a static-sensitive part.

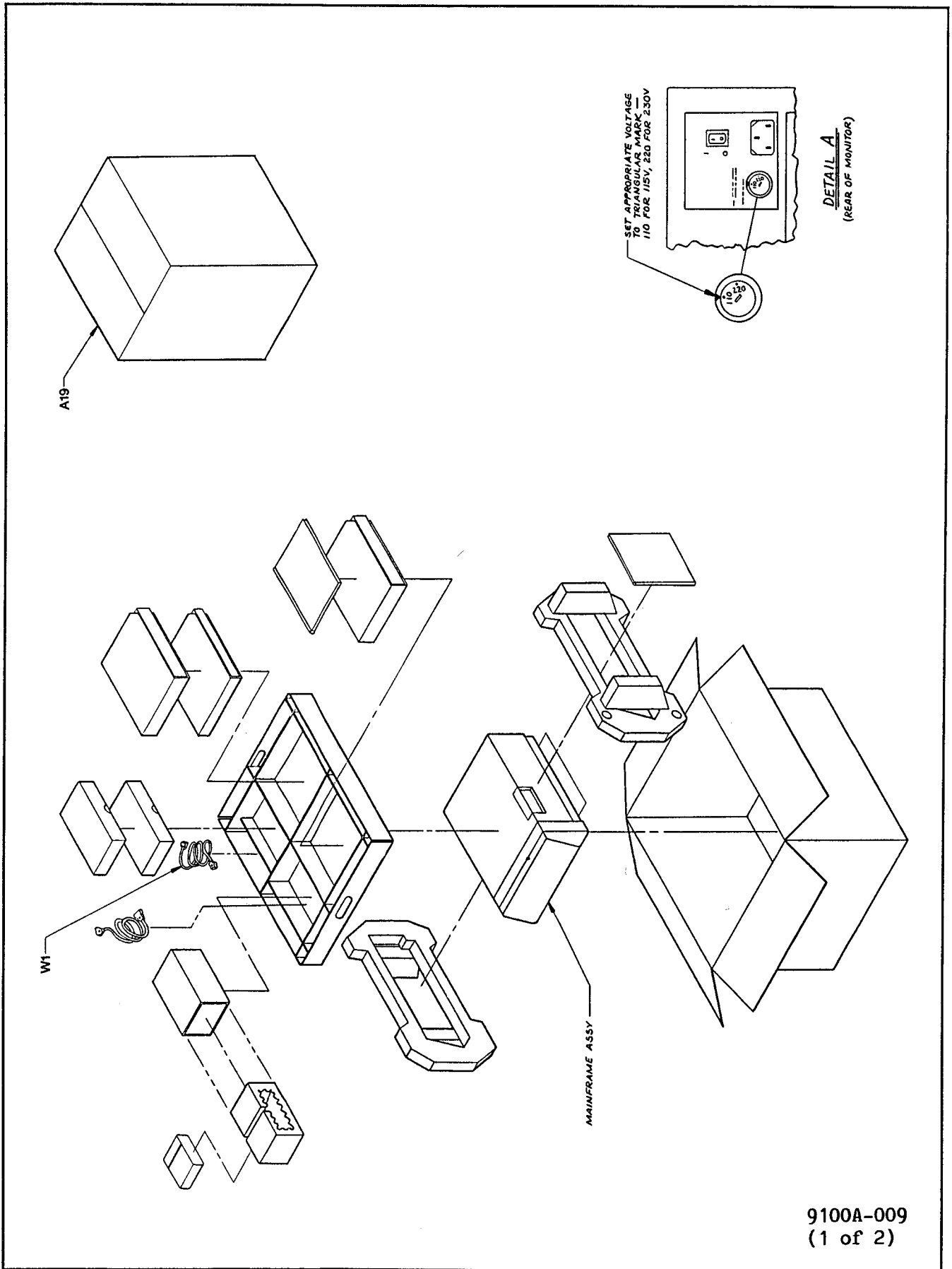

9100A-009
(1 of 2)

Figure 5-17. Option -009 Video, Monochrome
5-59

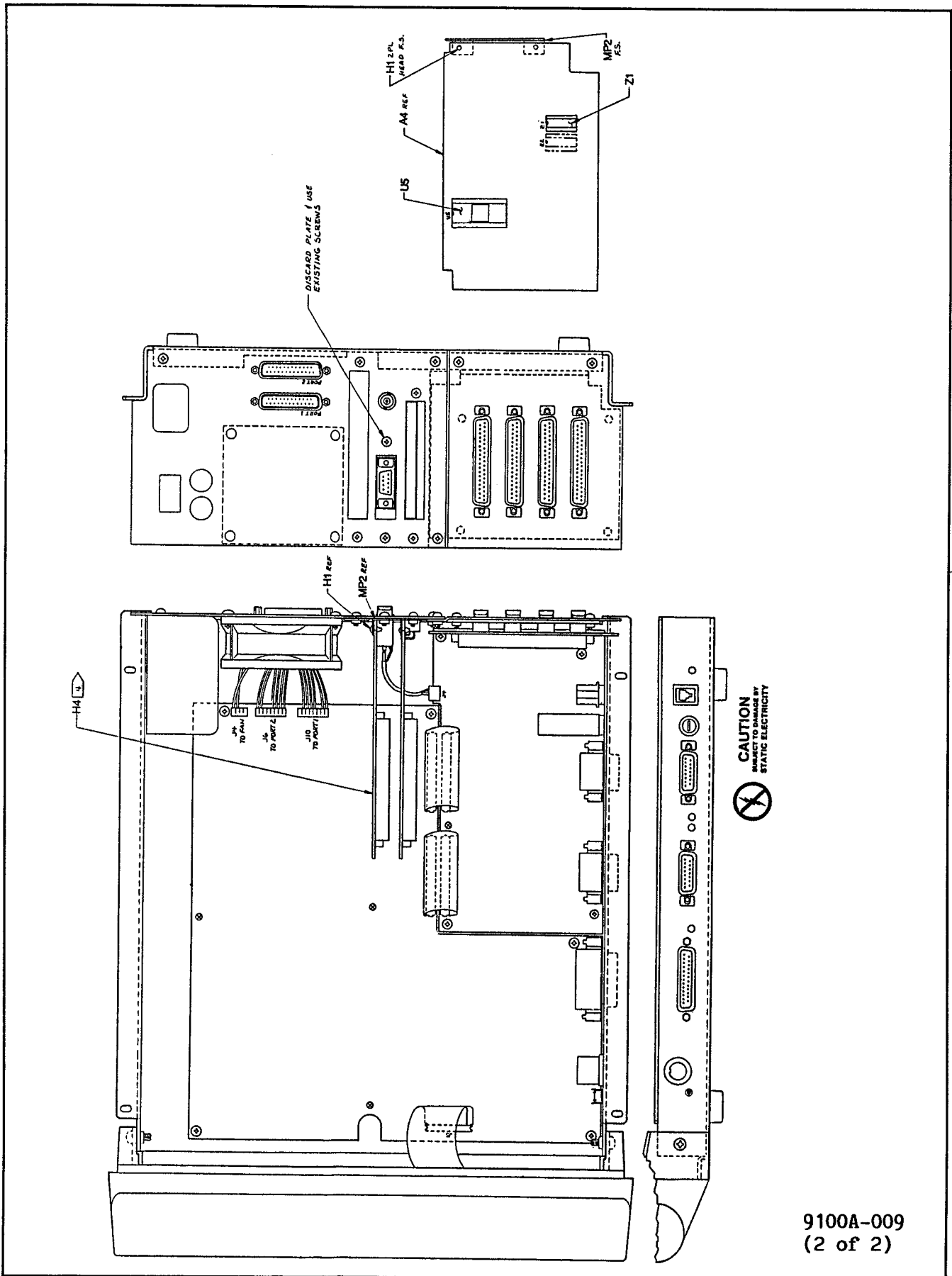

Figure 5-17. Option -009 Video, Monochrome (cont.)

5/List of Replaceable Parts

Table 5-24. Option -011 Video, Color
(See Figure 5-18.)

REFERENCE DESIGNATOR	-A>-NUMERICS	S	DESCRIPTION	FLUKE STOCK	MFRS SPLY	MANUFACTURERS PART NUMBER	TOT QTY	R S T	N O T
				--NO--	--CODE--	--OR GENERIC TYPE--			
A	4	*	VIDEO CONTROLLER PCA						
H	1		RIVET, POP, DOME, AL, 0.125X0.316	768762	89536	768762	1		
MP	2		VIDEO CONNECTOR BRACKET	423616	89536	423616	2		
U	5	*	PROGRAMMED 27128-150	768648	89536	768648	1		
Z	2		JUMPER, DIP, 0.300CTR, PROGRAM, 16 POS	818195	89536	818195	1		
				783183	89536	783183	1		

An * in 'S' column indicates a static-sensitive part.

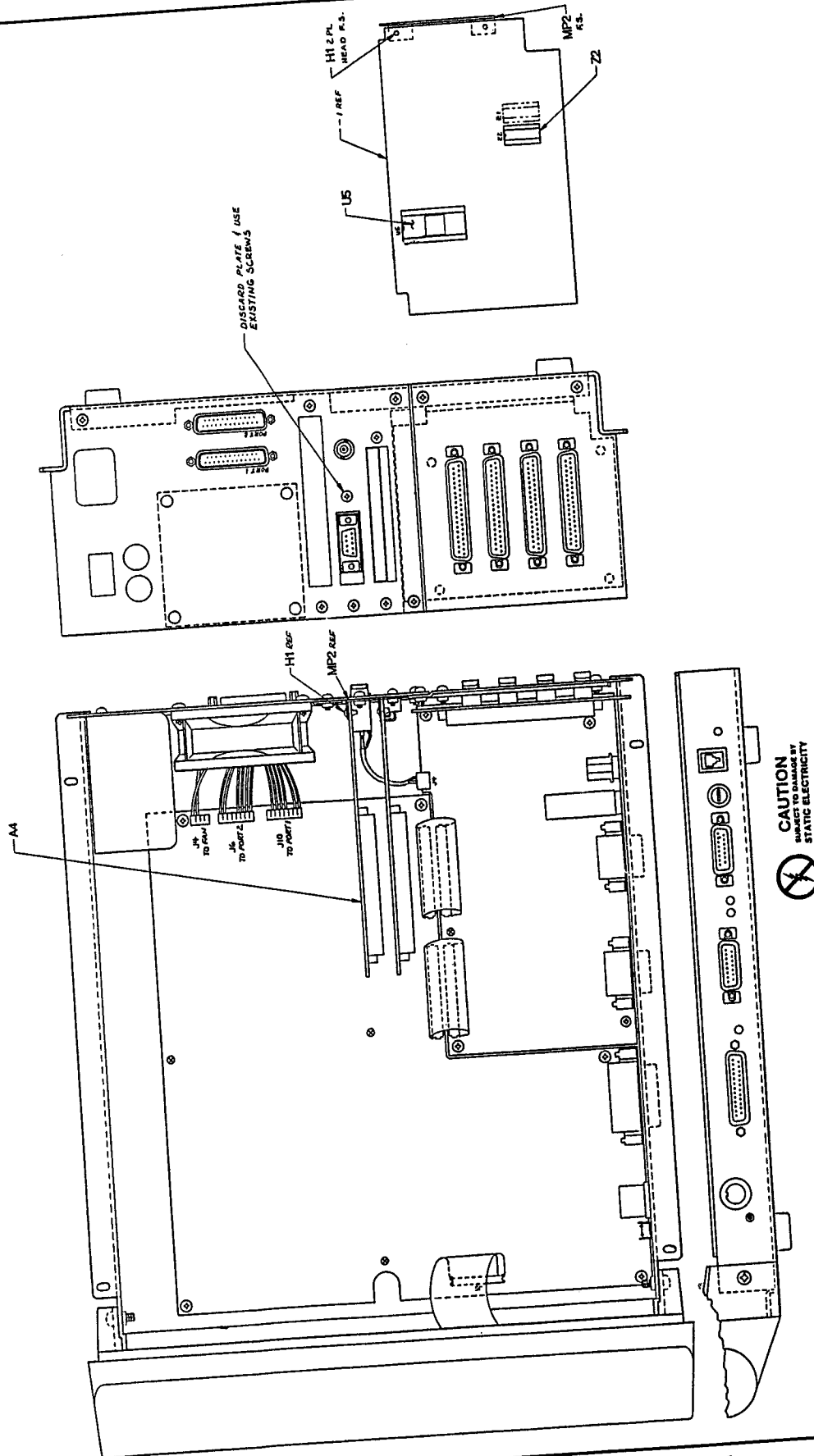

Figure 5-18. Option -011 Video, Color

9100A-011

5/List of Replaceable Parts

Table 5-25. Option -013 Programmer's Keyboard

REFERENCE DESIGNATOR	FLUKE STOCK	MFRS SPLY	MANUFACTURERS PART NUMBER	TOT QTY	N R O S T -Q -E-
-A>-NUMERICS-->	S-----	DESCRIPTION-----	--NO-- -CODE-	-OR GENERIC TYPE-----	
MP 1	*	ENCODER ASSEMBLY	783092	89536 783092	1
MP 2	*	MEMBRANE SWITCH ASSEMBLY	783076	89536 783076	1
MP 3		KEYCAP SET	783118	89536 783118	1
MP 4		TOP CASE	783035	89536 783035	1
MP 5		BASE	783084	89536 783084	1
W 1		CABLE	783043	89536 783043	1

An * in 'S' column indicates a static-sensitive part.



**Section 6
Appendices**

CONTENTS

Appendix A. Federal Supply Codes A-1
Appendix B. Fluke Sales and Service Centers B-1
Appendix C. Assembly Revision Information C-1

Appendix 6A
Federal Supply Codes

Federal Supply Codes for Manufacturers (cont)

08261 Spectra Strip Corp. Garden Grove, California	11726 Qualidyne Corp. Santa Clara, California	13606 Use 56289 Sprague Electric Co. Transistor Div. Concord, New Hampshire	16299 Corning Glass Electronic Components Div. Raleigh, North Carolina
08530 Reliance Mica Corp. Brooklyn, New York	12014 Chicago Rivet & Machine Co. Bellwood, Illinois	13839 Replaced by 23732	16332 Replaced by 28478
08806 General Electric Co. Miniature Lamp Products Dept Cleveland, Ohio	12040 National Semiconductor Corp. Danbury, Connecticut	14099 Semtech Corp. Newbury Park, California	16473 Cambridge Scientific Ind. Div. of Chemed Corporation Cambridge, Maryland
08863 Nylomatic Corp. Norrisville, Pennsylvania	12060 Diodes, Inc. Chatsworth, California	14140 Edison Electronic Div. Mc Gray-Edison Co. Manchester, New Hampshire	16742 Paramount Plastics Fabricators, Inc. Downey, California
08988 Use 53085 Skottie Electronics Inc. Archbald, Pennsylvania	12136 Philadelphia Handle Co. Camden, New Jersey	14193 Cal-R-Inc. formerly California Resistor, Corp. Santa Monica, California	16758 Delco Electronics Div. of General Motors Corp. Kokomo, Indiana
09214 G.E. Co. Semi-Conductor Products Dept. Power Semi-Conductor Products OPN Sec. Auburn, New York	12300 Potter-Brumfield Div. AMF Canada LTD. Guelph, Ontario, Canada	14298 American Components, Inc. an Insilco Co. Conshohocken, Pennsylvania	17001 Replaced by 71468
09353 C and K Components Watertown, Massachusetts	12327 Freeway Corp. formerly Freeway Washer & Stamping Co. Cleveland, Ohio	14655 Cornell-Dubler Electronics Division of Federal Pacific Electric Co. Govt. Control Dept. Newark, New Jersey	17069 Circuit Structures Lab. Burbank, California
09423 Scientific Components, Inc. Santa Barbara, California	12443 The Budd Co. Polychem Products Plastic Products Div. Bridgeport, Pennsylvania	14752 Electro Cube Inc. San Gabriel, California	17338 High Pressure Eng. Co., Inc. Oklahoma City, Oklahoma
09922 Burndy Corp. Norwalk, Connecticut	12615 U.S. Terminals Inc. Cincinnati, Ohio	14869 Replaced by 96853	17545 Atlantic Semiconductors, Inc. Asbury Park, New Jersey
09969 Dale Electronics Inc. Yankton, S. Dakota	12617 Hamlin Inc. Lake Mills, Wisconsin	14936 General Instrument Corp. Semi Conductor Products Group Hicksville, New York	17556 Siliconix, Inc. Santa Clara, California
10059 Barker Engineering Corp. Formerly Amerace, Amerace ESNA Corp. Kenilworth, New Jersey	12697 Clarostat Mfg. Co. Dover, New Hampshire	15636 Elec-Trol Inc. Saugus, California	17870 Replaced by 14140
11236 CTS of Berne Berne, Indiana	12749 James Electronics Chicago, Illinois	15801 Fenwal Electronics Inc. Div. of Kidde Walter and Co., Inc. Framingham, Massachusetts	18178 Vactec Inc. Maryland Heights, Missouri
11237 CTS Keene Inc. Paso Robles, California	12856 Micrometals Sierra Madre, California	15818 Teledyne Semiconductors, formerly Amelco Semiconductor Mountain View, California	18324 Signetics Corp. Sunnyvale, California
11358 CBS Electronic Div. Columbia Broadcasting System Newburyport, Minnesota	12954 Dickson Electronics Corp. Scottsdale, Arizona	15849 Litton Systems Inc. Useco Div. formerly Useco Inc. Van Nuys, California	18612 Vishay Resistor Products Div. Vishay Intertechnology Inc. Malvern, Pennsylvania
11403 Best Products Co. Chicago, Illinois	12969 Unitrode Corp. Watertown, Massachusetts	15898 International Business Machines Corp. Essex Junction, Vermont	18736 Voltronics Corp. Hanover, New Jersey
11503 Keystone Columbia Inc. Warren, Michigan	13103 Thermalloy Co., Inc. Dallas, Texas	15909 Replaced by 14140	18927 GTE Sylvania Inc. Precision Material Group Parts Division Titusville, Pennsylvania
11532 Teledyne Relays Hawthorne, California	13327 Solitron Devices Inc. Tappan, New York	16258 Space-Lok Inc. Burbank, California	19451 Perine Machinery & Supply Co. Seattle, Washington
11711 General Instrument Corp. Rectifier Division Hicksville, New York	13511 Amphenol Cadre Div. Bunker-Ramo Corp. Los Gatos, California		19701 Electro-Midland Corp. Mepco-Electra Inc. Mineral Wells, Texas
			20584 Enochs Mfg. Inc. Indianapolis, Indiana

Federal Supply Codes for Manufacturers (cont)

20891 Self-Organizing Systems, Inc. Dallas, Texas	28480 Hewlett Packard Co. Corporate HQ Palo Alto, California	43543 Nytronics Inc. Transformer Co. Div. Geneva, New York	70903 Belden Corp. Geneva, Illinois
21604 Bucheye Stamping Co. Columbus, Ohio	28520 Heyman Mfg. Co. Kenilworth, New Jersey	44655 Ohmite Mfg. Co. Skokie, Illinois	71002 Birnbach Radio Co., Inc. Freeport, New York
21845 Solitron Devices Inc. Transistor Division Riveria Beach, Florida	29083 Monsanto, Co., Inc. Santa Clara, California	49671 RCA Corp. New York, New York	71400 Bussmann Mfg. Div. of McGraw-Edison Co. Saint Louis, Missouri
22767 ITT Semiconductors Palo Alto, California	29604 Stackpole Components Co. Raleigh, North Carolina	49956 Raytheon Company Lexington, Massachusetts	71450 CTS Corp. Elkhart, Indiana
23050 Product Comp. Corp. Mount Vernon, New York	30148 AB Enterprise Inc. Ahoskie, North Carolina	50088 Mostek Corp. Carrollton, Texas	71468 ITT Cannon Electric Inc. Santa Ana, California
23732 Tracor Inc. Rockville, Maryland	30323 Illinois Tool Works, Inc. Chicago, Illinois	50579 Litronix Inc. Cupertino, California	71482 Clare, C.P. & Co. Chicago, Illinois
23880 Stanford Applied Engrng. Santa Clara, California	31091 Optimax Inc. Colmar, Pennsylvania	51605 Scientific Components Inc. Linden, New Jersey	71590 Centrelab Electronics Div. of Globe Union Inc. Milwaukee, Wisconsin
23938 Pamotor Div., Wm. J. Purdy Co. Burlingame, California	32539 Mura Corp. Great Neck, New York	53021 Sangamo Electric Co. Springfield, Illinois	71707 Colo Coil Co., Inc. Providence, Rhode Island
24248 Replaced by 94222	32767 Griffith Plastic Corp. Burlingame, California	54294 Cutler-Hammer Inc. formerly Shallcross, A Cutter-Hammer Co. Selma, North Carolina	71744 Chicago Miniature Lamp Works Chicago, Illinois
24355 Analog Devices Inc. Norwood, Massachusetts	32879 Advanced Mechanical Components Northridge, California	55026 Simpson Electric Co. Div. of Am. Gage and Mach. Co. Elgin, Illinois	71785 TRW Electronics Components Cinch Connector Operations Div. Elk Grove Village Chicago, Illinois
24655 General Radio Concord, Massachusetts	32897 Erie Technological Products, Inc. Frequency Control Div. Carlisle, Pennsylvania	56289 Sprague Electric Co. North Adams, Massachusetts	72005 Wilber B. Driver Co. Newark, New Jersey
24759 Lenox Fugle Electronics Inc. South Plainfield, New Jersey	32997 Bourns Inc. Trimpot Products Division Riverside, California	58474 Superior Electric Co. Bristol, Connecticut	72092 Replaced by 06980
25088 Siemen Corp. Isilen, New Jersey	33173 General Electric Co. Products Dept. Owensboro, Kentucky	60399 Torin Corp. formerly Torrington Mfg. Co. Torrington, Connecticut	72136 Electro Motive Mfg. Co. Williamantic, Connecticut
25403 Amperex Electronic Corp. Semiconductor & Micro-Circuits Div. Slatersville, Rhode Island	34333 Silicon General Westminister, California	63743 Ward Leonard Electric Co., Inc. Mount Vernon, New York	72259 Nytronics Inc. Peiham Manor, New Jersey
27014 National Semiconductor Corp. Santa Clara, California	34335 Advanced Micro Devices Sunnyvale, California	64834 West Mfg. Co. San Francisco, California	72619 Dialight Div. Amperex Electronic Corp. Brooklyn, New York
27264 Molex Products Downers Grove, Illinois	34802 Electromotive Inc. Kenilworth, New Jersey	65092 Weston Instruments Inc. Newark, New Jersey	72653 G.C. Electronics Div. of Hydrometals, Inc. Brooklyn, New York
28213 Minnesota Mining & Mfg. Co. Consumer Products Div. St. Paul, Minnesota	37942 P.R. Mallory & Co., Inc. Indianapolis, Indiana	66150 Winslow Tele-Tronics Inc. Eaton Town, New Jersey	72665 Replaced by 90303 72794 Dzus Fastener Co., Inc. West Islip, New York
28425 Serv-/Link formerly Bohannan Industries Fort Worth, Texas	42498 National Radio Melrose, Massachusetts	70485 Atlantic India Rubber Works Chicago, Illinois	72928 Gulton Ind. Inc. Gudeman Div. Chicago, Illinois
28478 Deltrol Controls Div. Deltrol Corporation Milwaukee, Wisconsin		70563 Amperite Company Union City, New Jersey	

Federal Supply Codes for Manufacturers (cont)

72982 Erie Tech. Products Inc. Erie, Pennsylvania	75382 Kulka Electric Corp. Mount Vernon, New York	80583 Hammarlund Mfg. Co., Inc. Red Bank, New Jersey	83584 Burrhoughs Corp. Electronic Components Div. Plainfield, New Jersey
73138 Bechman Instrument Inc. Helipot Division Fullerton, California	75915 Littlefuse Inc. Des Plaines, Illinois	80640 Arnold Stevens, Inc. South Boston, Massachusetts	83740 Union Carbide Corp. Battery Products Div. formerly Consumer Products Div. New York, New York
73293 Hughes Aircraft Co. Electron Dynamics Div. Torrance, California	76854 Oak Industries Inc. Switch Div. Crystal Lake, Illinois	81073 Grayhill, Inc. La Grange, Illinois	84171 Arco Electronics Great Neck, New York
73445 Ampere Electronic Corp. Hicksville, New York	77342 AMF Inc. Potter & Brumfield Div. Princeton, Indiana	81312 Winchester Electronics Div. of Litton Industries Inc. Oakville, Connecticut	84411 TRW Electronic Components TRW Capacitors Ogallala, Nebraska
73559 Carling Electric Inc. West Hartford, Connecticut	77638 General Instrument Corp. Rectifier Division Brooklyn, New York	81483 Therm-O-Disc Inc. Mansfield, Ohio	84613 Fuse Indicator Corp. Rockville, Maryland
73586 Circle F Industries Trenton, New Jersey	77969 Rubbercraft Corp. of CA. LTD. Torrance, California	81483 International Rectifier Corp. Los Angeles, California	84682 Essex International Inc. Industrial Wire Div. Peabody, Massachusetts
73734 Federal Screw Products, Inc. Chicago, Illinois	78189 Shakeproof Div. of Illinois Tool Works Inc. Elgin, Illinois	81590 Korry Mfg. Co. Seattle, Washington	86577 Precision Metal Products of Malden Inc. Stoneham, Massachusetts
73743 Fischer Special Mfg. Co. Cincinnati, Ohio	78277 Sigma Instruments, Inc. South Braintree, Massachusetts	81741 Chicago Lock Co. Chicago, Illinois	86684 Radio Corp. of America Electronic Components Div. Harrison, New Jersey
73899 JFD Electronics Co. Components Corp. Brooklyn, New York	78488 Stackpole Carbon Co. Saint Marys, Pennsylvania	82305 Palmer Electronics Corp. South Gate, California	86928 Seastrom Mfg. Co., Inc. Glendale, California
73949 Guardian Electric Mfg. Co. Chicago, Illinois	78553 Eaton Corp. Engineered Fastener Div. Tinnerman Plant Cleveland, Ohio	82389 Switchcraft Inc. Chicago, Illinois	87034 Illuminated Products Inc. Subsidiary of Oak Industries Inc. Anaheim, California
74199 Ouan Nichols Co. Chicago, Illinois	79136 Waldes Kohinoor Inc. Long Island City, New York	82415 North American Phillips Controls Corp. Frederick, Maryland	88219 Gould Inc. Industrial Div. Trenton, New Jersey
74217 Radio Switch Corp. Marlboro, New Jersey	79497 Western Rubber Company Goshen, Indiana	82872 Roanwell Corp. New York, New York	88245 Litton Systems Inc. Useco Div. Van Nuys, California
74276 Signalite Div. General Instrument Corp. Neptune, New Jersey	79963 Zierick Mfg. Corp. Mt. Kisko, New York	82877 Rotron Inc. Woodstock, New York	88419 Cornell-Dubilier Electronic Div. Federal Pacific Co. Fuquay-Varian, North Carolina
74306 Piezo Crystal Co. Carlisle, Pennsylvania	80031 Electro-Midland Corp. Mepco Div. A North American Phillips Co. Norristown, New Jersey	82879 ITT Royal Electric Div. Pawtucket, Rhode Island	88486 Plastic Wire & Cable Jewitt City, Connecticut
74542 Hoyt Elect. Instr. Works Penacook, New Hampshire	80145 LFE Corp., Process Control Div. formerly API Instrument Co. Chesterland, Ohio	83003 Varo Inc. Garland, Texas	88690 Replaced by 04217
74970 Johnson E.F., Co. Waseca, Minnesota	80183 Use 56289 Sprague Products North Adams, Massachusetts	83058 The Carr Co., United Can Div. of TRW Cambridge, Massachusetts	89536 John Fluke Mfg. Co., Inc. Seattle, Washington
75042 TRW Electronics Components IRC Fixed Resistors Philadelphia, Pennsylvania	80294 Bourns Inc., Instrument Div. Riverside, California	83298 Bendix Corp. Electric Power Div. Eatontown, New Jersey	89730 G.E. Co., Newark Lamp Works Newark, New Jersey
75376 Kurz-Kasch Inc. Dayton, Ohio		83330 Herman H. Smith, Inc. Brooklyn, New York	
75378 CTS Knights Inc. Sandwich, Illinois		83478 Rubbercraft Corp. of America, Inc. West Haven, Connecticut	

Federal Supply Codes for Manufacturers (cont)

90201 Mallory Capacitor Co. Div. of P.R. Mallory Co., Inc. Indianapolis, Indiana	91836 King's Electronics Co., Inc. Tuckahoe, New York	95354 Methode Mfg. Corp. Rolling Meadows, Illinois	98291 Sealectro Corp. Mamaroneck, New York
90211 Use 56365 Square D Co. Chicago, Illinois	91929 Honeywell Inc. Micro Switch Div. Freeport, Illinois	95712 Bendix Corp. Electrical Components Div. Microwave Devices Plant Franklin, Indiana	98388 Royal Industries Products Div. San Diego, California
90215 Best Stamp & Mfg. Co. Kansas City, Missouri	91934 Miller Electric Co., Inc. Div. of Aunet Woonsocket, Rhode Island	95987 Weckesser Co. Inc. Chicago, Illinois	98743 Replaced by 12749
90303 Mallory Battery Co. Div. of Mallory Co., Inc. Tarrytown, New York	92194 Alpha Wire Corp. Elizabeth, New Jersey	96733 San Fernando Electric Mfg. Co. San Fernando, California	98925 Replaced by 14433
91094 Essex International Inc. Suglex/IWP Div. Newmarket, New Hampshire	93332 Sylvania Electric Products Semiconductor Products Div. Woburn, Massachusetts	96853 Gulton Industries Inc. Measurement and Controls Div. formerly Rustrak Instruments Co. Manchester, New Hampshire	99120 Plastic Capacitors, Inc. Chicago, Illinois
91293 Johanson Mfg. Co. Boonton, New Jersey	94145 Replaced by 49956	96881 Thomson Industries, Inc. Manhasset, New York	99217 Bell Industries Elect. Comp. Div. formerly Southern Elect. Div. Burbank, California
91407 Replaced by 58474	94154 Use 94988 Wagner Electric Corp. Tung-Sol Div. Newark, New Jersey	97540 Master Mobile Mounts, Div. of Whitehall Electronics Corp. Ft. Meyers, Florida	99392 STM Oakland, California
91502 Associated Machine Santa Clara, California	94222 Southco Inc. formerly South Chester Corp. Lester, Pennsylvania	97913 Industrial Electronic Hardware Corp. New York, New York	99515 ITT Jennings Monrovia Plant Div. of ITT Jennings formerly Marshall Industries Capacitor Div. Monrovia, California
91508 Augat Inc. Attleboro, Massachusetts	95146 Alco Electronic Products Inc. Lawrence, Massachusetts	97945 Penwall Corp. SS White Industrial Products Div. Piscataway, New Jersey	99779 Use 29587 Bunker-Ramo Corp. Barnes Div. Landsdowne, Pennsylvania
91637 Dale Electronics Inc. Columbus, Nebraska	95263 Leecraft Mfg. Co. Long Island City, New York	97966 Replaced by 11358	99800 American Precision Industries Inc. Delevan Division East Aurora, New York
91662 Elco Corp. Willow Grove, Pennsylvania	95264 Replaced by 98278	98094 Replaced by 49956	99942 Centrelab Semiconductor Centrelab Electronics Div. of Globe-Union Inc. El Monte, California
91737 Use 71468 Gremar Mfg. Co., Inc. ITT Cannon/Gremar Santa Ana, California	95275 Vitramon Inc. Bridgeport, Connecticut	98159 Rubber-Teck, Inc. Gardena, California	70943 Toyo Electronics (R-Ohm Corp.) Irvine, California
91802 Industrial Devices, Inc. Edgewater, New Jersey	95303 RCA Corp. Receiving Tube Div. Cincinnati, Ohio	98278 Malco A Microdot Co., Inc. Connector & Cable Div. Pasadena, California	National Connector Minneapolis, Minnesota
91833 Keystone Electronics Corp. New York, New York	95348 Gordo's Corp. Bloomfield, New Jersey		

Appendix 6B
Fluke Sales and Service Centers

U.S. SALES AREAS for all Fluke products**Alabama**

Huntsville
4920 Corporate Drive
Suite J
Huntsville, AL 35805-6202
(205) 837-0581

Arizona

Tempe
2211 S. 48th Street
Suite B
Tempe, AZ 85282
(602) 438-8314

Tucson
(602) 790-9881

California

Burbank
2020 N. Lincoln Street
Burbank, CA 91504
(213) 849-7181

Northern
2300 Walsh Ave., Bldg. K
Santa Clara, CA 95051
(408) 727-0513

San Diego
(619) 292-7657

Southern
P.O. Box 19676
Irvine, CA 92713-9676
16969 Von Karman
Suite 100
Irvine, CA 92714
(714) 863-9031

Colorado

Denver
14180 E. Evans Ave.
Aurora, CO 80014
(303) 695-1000

Connecticut

Hartford
Glen Lochen East
41-C New London Turnpike
Glastonbury, CT 06033
(203) 659-3541

Florida

Clearwater
(813) 799-0087

Miami
(305) 462-1380

Orlando
940 N. Fern Creek Ave.
Orlando, FL 32803
(305) 896-4881

Tampa
(813) 251-9211

Georgia

Atlanta
2700 Delk Road
Suite 150
Marietta, GA 30067
(404) 953-4747

Illinois

Chicago
1150 W. Euclid Avenue
Palatine, IL 60067
(312) 705-0500

Indiana

Indianapolis
8777 Purdue Road
Suite 101
Indianapolis, IN 46268
(317) 875-7870

Louisiana

New Orleans
(504) 455-0814

Massachusetts

Boston
Middlesex Technology Center
900 Middlesex Turnpike
Building 8
Billerica, MA 01821
(617) 663-2400

Maryland

Baltimore
(301) 792-7060

Rockville
5640 Fishers Lane
Rockville, MD 20852
(301) 770-1570

Michigan

Detroit
33031 Schoolcraft
Livonia, MI 48150
(313) 522-9140

Minnesota

Bloomington
1801 E. 79th St.
Suite 9
Bloomington, MN 55420
(612) 854-5526

Missouri

St. Louis
11756 Borman Drive
Suite 160
St. Louis, MO 63146
(314) 993-3805

North Carolina

Greensboro
1310 Beaman Place
Greensboro, NC 27408
(919) 273-1918

New Jersey

Paramus
P.O. Box 930
Paramus, NJ 07653-0930
West 75 Century Road
Paramus, NJ 07652
(201) 262-9550

New Mexico

Albuquerque
(505) 881-3550

New York

Rochester
4515 Culver Road
Rochester, NY 14622
(716) 323-1400

Ohio

Cleveland
Plaza South Three
Suite 402
7271 Engle Road
Middleburg Heights, OH 44130
(216) 234-4540

Oklahoma

Northeast
(405) 236-2977

Oregon

Portland
(503) 227-2042

Pennsylvania

Malvern
200 Lindenwood Drive
Malvern, PA 19355
(215) 647-9550

Pittsburgh
(412) 261-5171

Texas

Austin
(512) 459-3344

Dallas
1801 Royal Lane
Suite 307
Dallas, TX 75229
(214) 869-0311

El Paso
(915) 533-3508

Houston
(713) 240-5995

San Antonio
10417 Gulfdale
San Antonio, TX 78216
(512) 340-0498

Utah

Salt Lake City
(801) 268-9331

Washington

Seattle
5020 148th Ave. N.E.
Suite 110
Redmond, WA 98052
(206) 881-6966

Washington, DC

Washington, DC
(301) 770-1570

INTERNATIONAL SALES OFFICES

Algeria

Bureau de Liaison Phillips
(For Philips products)
24 rue Bougainville
El Mouradia, Alger
Tel: 60 14 05
TLX: 62221

Antilles

Philips Antillana N.V.
(For Philips products)
Schottegatweg Oost 146
P.O. Box 3523
Willemstad, Curacao
Tel: 599-9-615277
TLX: 1047

Argentina

Coasin S.A.
(For Fluke products)
Virrey del Pino 4071DPTO E-65
1430 CAP FED
Buenos Aires, Argentina
Tel: (54) (1) 552-5248
TLX: (390) 22284

Philips Argentina S.A.

(For Philips products)
Casilla Correo 3479
Vedia 3892
1430 Buenos Aires
Tel: 54-1-5414106/5417141
TLX: 21359/21243

Australia

Elmeasco Instruments Pty, Ltd.
(For Fluke products)
P.O. Box 30
Concord, N.S.W. 2137
Australia
Tel: (61) (2) 736-2888
TLX: (790) AA25887
FAX: (61) 2-733663

Elmeasco Instruments Pty, Ltd.

(For Fluke products)
P.O. Box 623
12 Maroondah Highway
Ringwood, Victoria 3134
Australia
Tel: (61) (3) 879-2322
TLX: (790) AA30418
FAX: (61) 3-879-4310

Elmeasco Instruments Pty, Ltd.

(For Fluke products)
P.O. Box 274
Salisbury, Qld Australia 4107
Tel: (61) (7) 875-1444
TLX: (790) AA44062

Elmeasco Instruments Pty, Ltd.

(For Fluke products)
P.O. Box 154
Prospect, South Australia 5082
Tel: (61) (8) 344-9000

Elmeasco Instruments Pty, Ltd.

(For Fluke products)
32 Teddington Rd.
Victoria Park
Western Australia 6100
Tel: (61) 9-470-1855

Philips Scientific & Industrial

Equipment Division
(For Philips products)
CentreCourt 25-27 Paul Street
North Ryde
Sydney N.S.W. 2113
Tel: 88 88 222

Austria

**Walter Rekirsch Elektronische
Gerate GmbH & Co.**
(For Fluke products)
Vertrieb KG
Obachgasse 28
1220 Vienna, Austria
Tel: (43) (222) 253626
TLX: (847) 134759
FAX: (43) (222) 257275

Osterreichische Philips Industrie GmbH

(For Philips products)
Geschäftsbereich I & E
Marktbereich Test-und Meßgerate
A-1101 WIEN, Triester Straße 64
Tel: (0222) 60101/1772 DW

Bahrain

Basma W.L.L.
(For Fluke products)
P.O. Box 5701
Manama, Bahrain
Tel: (973) 251-364
TLX: (955) 9003
FAX: (965) 245218

Bangladesh

Motherland Corporation
(For Fluke products)
24 Halkhola Road, Tikatuli
Dacca-3, Bangladesh
Tel: 257249, TLX: (950) 642022

Philips Bangladesh Ltd.

(For Philips products)
P.O. Box 62, Ramna
16/17 Kawran Bazar C/A
DHAKA
Tel: 411976
TLX: 65668

Belgium

N.V. Philips Professional Systems S.A.
Test and Measurement
Tweestationsstraat 80
Rue des Deux Gares
Brussel 1070 Bruxelles
Tel: 2-5256111

Bolivia

Coasin Bolivia S.R.L.
(For Fluke products)
Casilla 7295
La Paz, Bolivia
Tel: (591) (2) 40962
TLX: (336) 3233 COALAP BV

Brazil

ATP Hi-Tek Eletronica Ltda.
(For Fluke products)
Al. Amazonas 422, Alphaville
Barueri
CEP 06400, Sao Paulo, Brazil
Tel: (55) (11) 421-5477
TLX: (391) 1171413

Philips do Brasil Ltda.

(For Philips products)
Av. Eng. Luiz Carlos Berrini 3009
Caixa Postal 8681
04571 SAO PAULO S.P.
Tel: 55-11-2411611
TLX: (011) 32750

Brunei

Rank O'Connor's, Sdn Bhd
(For Fluke products)
No. 8 Block D,
Sufri Shophouse Complex
Mile 1 Jalan Tutong
Bandar Seri Begawan
Negara Brunei Darussalam
Tel: (673) (2) 23109 or 23557
TLX: (799) BU2265 RANKOC

Canada

Fluke Electronics Canada Inc.
400 Britannia Rd. East Unit #1
Mississauga, Ontario
L4Z 1X9 Canada
Tel: (416) 890-7600
FAX: (416) 890-6866

Fluke Electronics Canada Inc.

1690 Woodward Drive
Suite 216
Ottawa, Ontario
K2C 3R8 Canada
Tel: (613) 723-9453
FAX: (613) 723-9458

Fluke Electronics Canada Inc.

1255 Trans Canada Highway
Suite 130
Dorval, Quebec
H9P 2V4 Canada
Tel: (514) 685-0022
FAX: (514) 685-0039

Fluke Electronics Canada Inc.

101, 1144 - 29th Ave. N.E.
Calgary, Alberta
T2E 7P1 Canada
Tel: (403) 291-5215
FAX: (403) 291-5219

Chile

Intronica Chile, Ltda.
(For Fluke products)
Casilla 16228
Santiago 9, Chile
Tel: (56) 2-2321886
TLX: (332) 346351

Philips Chilena S.A.

de Produc. Electr.
(For Philips products)
Avenida Santa Maria 0760
Casilla 2687
Santiago De Chile
Tel: 56-2-770038
TLX: 240239

China, Peoples Republic of

Fluke International Corp.
(For Fluke products)
P.O. Box C9090 M/S 206A
Everett, WA 98206 U.S.A.
Tel: (206) 356-5511
TLX: 185103 FLUKE UT
FAX: (206) 356-5116

Colombia

Sistemas E Instrumentacion, Ltda.
(For Fluke products)
Carrera 13, No. 37-43, Of. 401
Ap. Aereo 29583
Bogota DE, Colombia
Tel: (57) 232-4532
TLX: (396) 45787

Industrias Philips de Colombia S.A.

(For Philips products)
Apartado Aereo 4282
Calle 13 No. 51-39
Bogota
Tel: 57-1-2600600
TLX: Philcolon 44776

Cyprus

Chris Radiovision, Ltd.
(For Fluke products)
P.O. Box 1989
Nicosia, Cyprus
Tel: (357) (21) 66121
TLX: (826) 2395

Cyprus, Northern

Ucok Buroteknik
(For Fluke products)
2C & 2D Muftu Ziyai Street
Lefkosa, Northern Cyprus
Mersin 10, Turkey
Tel: (90) (741) 357-20-71777
TLX: (821) 57267

Denmark

Tege Olsen A/S
(For Fluke products)
Ballerup Byevej 222
2750 Ballerup
Denmark
Tel: (45) (2) 658111
TLX: (855) 35293
FAX: (45) 2-680 300

Philips A/S Test & Measurement

(For Philips products)
Prags Boulevard 80
DK-2300-Kobenhavn S
Tel: (01) 572222
TLX: 31201

Ecuador

Proteco Coasin Cia., Ltda.
(For Fluke products)
P.O. Box 228-A
Ave. 12 de Octubre 2285
y Orellana
Quito, Ecuador
Tel: (593) (2) 529684
TLX: (393) 22085

Philips Ecuador S.A.

(For Philips products)
Casilla 343
Paez 118 y Avenida Patria
Quito
Tel: 593-2-546100/546125
TLX: 2227 PHLPSQ ED

Proteco Coasin Cia., Ltda.

(For Fluke products)
P.O. Box 9733
Ave. Principal No. 204 y Calle Segunda
Urbanizacion Miraflores
Guayaquil, Ecuador
Tel: (593) (4) 387519

Egypt and Sudan

**Electronic Engineering
Liaison Office**
(For Fluke products)
P.O. Box 2891 Horreya
11361 Heliopolis, Cairo
Egypt
Tel: (20) 2-695705
TLX: (927) 22782

Philips Egypt Liaison Office of Philips
(For Philips products)
Export B.V.
10, Abdel Rahman el Rafei Str.
P.O. Box 1687
Dokki, Cairo
Tel: 20-2-3490922
TLX: 22816 PHEGY UN

Ethiopia
(For Philips products)
Philips Ethiopia (Priv. Ltd. Co.)
Ras Abebe Areguay Avenue
P.O. Box 2565
Addis Ababa
Tel: 148300

Fiji
Awa New Zealand Ltd.
(For Fluke products)
37 Freestone Walu Bay Road
P.O. Box 858
Suva, Fiji
Tel: (679) 312079
TLX: (792) 2347
FAX: (679) 314379

Finland
Instrumentarium Elektroniikka
(For Fluke products)
P.O. Box 64
02631 Espoo 63
Finland
Tel: (358) (0) 5281
TLX: (857) 124426
FAX: (358) 0-502-1073

OY Philips AB
(For Philips products)
P.O. Box 11
02631 ESPOO
Tel: 0-5257225

France
M.B. Electronique S.A.
(For Fluke products)
606 Rue Fournay
P.O. Box 31
78530 BUC, France
Tel: (33) (1) 39568131
TLX: (842) 695414
FAX: (33) (1) 3956-53-44

S.A. Philips Industrielle et Commercials
Division Science et Industrie
(For Philips products)
105 rue de Paris, BP 62
93002 BOBIGNY Cedex
Tel: (1) 49 42 80 80
TLX: 210290

Germany
Philips GmbH
(For Philips products)
Unternehmensbereich
Elektronik für Wissenschaft
und Industrie
Vertriebsbereich Testr and Meßtechnik
Miramstraße 87 Postfach 310320
D-3500 KASSEL
Tel: (0561) 5010, TLX: 997070

Bereich Fluke Produkte
Oskar-Messter-Strape 18
D-8045 Ismaning

Great Britain
Philips Test & Measurement
York Street
Cambridge CB1 2PX
Tel: (0223) 358866
TLX: 817331

Philips Test & Measurement
(For Fluke products)
Colonial Way
Watford WD2 4TT

Greece
Hellenic Scientific Representations Ltd.
(For Fluke products)
11 Vrassida Street
Athens 612, Greece
Tel: (30) (1) 7211140
TLX: (863) 219330

Philips S.A. Hellenique I&E Division
(For Philips products)
15, 25th March Street
GR-17778 TAVROS or
P.O. Box 3153 Athens
Tel: 30-1-4894911
TLX: 241566-241567

Hong Kong
Fluke Asia Ltd.
(For Fluke products)
Shun Tak Centre
Suite No. 1501
200 Connaught Road
Central, Hong Kong
Tel: (852) 5-482116
FAX: (852) 5-479863
TLX: (780) 87058 Fluke HX

Philips Hong Kong Ltd.
(For Philips products)
29/F Hopewell Centre
17 Kennedy Road
G.P.O. Box 2108
Hong Kong
Tel: 852-5-283298
TLX: 73660 PHILH HX

Schmidt & Co (H.K.), Ltd
(For Fluke products)
18th Floor, Great Eagle Centre
23 Harbour Road
Wanchai, Hong Kong
Tel: (852) (5) 8330-222
TLX: (780) 74766 or 76762
FAX: (852) 5-8918754

India
Hinditron Services Pvt., Ltd.
(For Fluke products)
69/A.L. Jagmohandas Marg
Bombay 400 006, India
Tel: (22) 8121316, (91) (22) 8125344
TLX: (953) 1175326

Hinditron Services Pvt., Ltd.
(For Fluke products)
8th Main Road
33/44A Raj Mahal Vilas Extension
Bangalore 560 080, India
Tel: (91) 812-363139, TLX: (953) 8452741

Hinditron Services Pvt. Ltd.
(For Fluke products)
5th Floor, "Castle House"
5/1A, Hungerford St.
Calcutta 700 017, India
Tel: (91) 33-432628, TLX (953) 21-4153

Hinditron Services Pvt. Ltd.
(For Fluke products)
204-5-6 Hemkunt Tower
98 Nehru Place
New Delhi, 110019, India
Tel: (91) 11-6410380, TLX: (953) 316458

Hinditron Services Pvt., Ltd.
(For Fluke products)
Emerald Complex 1-7-264
5th Floor
114 Sarojini Devi Rd.
Secunderabad 500 003, India
Tel: 842 821117, TLX: (953) 04256973

Peico Electronics & Electricals Ltd.
(For Philips products)
Shivsagar Estate, Block 'A'
Dr. Annie Besant Road
P.O.B. 6598
Worli, Bombay 400018
Tel: 4921500/4921513

Indonesia
P.T. Lamda Triguna
(For Fluke products)
Tel: (62) 21-8195365
TLX: (796) 45483 LOMAS I.A.
P.O. Box: 6/JATJG, Jakarta 13001

P.T. Daeng Brothers
(For Philips products)
Centre Point Building, 3rd Fl.
Jalan Gatot Subroto Kav. 35/36
P.O. Box 41 Tebet
Jakarta
Tel: 62-21-517900
TLX: 62798 PHDC IA

Iran
Philips Iran Ltd.
(For Philips products)
(Private Joint Stock Comp.)
P.O. Box 11365-3891
Tehran
Tel: 98-21-674138
TLX: 212545 PHPS IR

Iraq
Philips Midden Oosten B.V.
(For Philips products)
Baghdad Branch
Hai Al Whida. Area No. 902
Street No. 12, Bldg. 141/10
P.O. Box 5749
Baghdad
Tel: 7187181
TLX: 212439 Philips IK

Ireland
Circuit Specialists Limited
(For Fluke products)
Unit 5 Enterprise Centre
Plassey Technological Park
Castleroy, Limerick
Ireland
Tel: (852) (61) 330333
TLX: (852) 70092

P.J. Brennan and Company Ltd.
(For Philips products)
61 Stillorgan Industrial Park
Stillorgan, Co. Dublin
Tel: 952501
TLX: 3817
FAX: 952333

Israel
R.D.T. Electronics Engineering Ltd.
P.O. Box 43137
Tel Aviv 61430
Israel
Tel: (972) (3) 483211, TLX: 371452
FAX: 972-3-492190

Italy
Sistrel S.p.A.
(For Fluke products)
Via Pelizza da Volpedo 59
20092 Cinisello Balsamo
Milan, Italy
Tel: (39) (2) 6181893, TLX: (843) 334643
FAX: (39) 2-6182440

Sistrel S.p.A.
(For Fluke products)
Via le Erminio Spalla No. 41
00142 Rome, Italy
TLX: (843) 625857, FAX (39) 6-504137

Sistrel S.p.A.
(For Fluke products)
Via Cintia
Parco S. Paolo 35
80126 Naples, Italy
Tel: (39) (81) 7679700
FAX (39) 81-7661361

Philips S.p.A.
(For Philips products)
Sezione S & I, T & M Dept.
Viale Elvezia 2
20052 Monza
Tel: (039) 3635240/8/9
TLX: 333343

Japan
John Fluke Mfg. Co., Inc.
Japan Branch
(For Fluke products)
Sumitomo Higashi Shinbashi Bldg.
1-1-11 Hamamatsucho
Minato-ku, Tokyo 105, Japan
Tel: (81) (3) 434-0181
TLX: (781) 2424331
FAX: 81-3-434-0170

John Fluke Mfg. Co., Inc.
Japan Branch
(For Fluke products)
Katsushige Building
2-45 Kohraibashi
Higashi-ku, Osaka 541
Japan
Tel: (81) (6) 229-0871
FAX: 81-6-229-1098

NF Circuit Design Block Co., Ltd.
(For Philips products)
3-20 Tsunashima Higashi, 6-Chome,
Kokokoku, Yokohama 223
Tel: (045) 452-0411
TLX: 3823-297

Kenya
Philips (Kenya) Ltd.
(For Philips products)
OL Kalou Road, Industrial Area
P.O. Box 30554
Nairobi
Tel: 254-2-557999, TLX: 22225 Nairobi

Korea, Republic of
Myoung Corporation
 (For Fluke products)
 Yeo Eui Do
 P.O. Box 14
 Seoul, Korea
 Tel: (82) (2) 784-9942
 TLX: MYOUNG K24283
 FAX (82) 2-784-2387

Kuwait
Al Bahar International Group
 (For Fluke products)
 P.O. Box 26672 Safat
 13127 Safat, Kuwait
 Tel: (965) 848601, TLX: (959) 44822

Lebanon and Jordan
Mabek (Electronic Division)
 (For Fluke products)
 P.O. Box 13-5657
 Beirut, Lebanon
 Tel: 812523, TLX: (923) 22889

Philips Middle East S.A.R.L.
 (For Philips products)
 B.P. 11-670
 Ave. Sami Solh
 Beyrouth
 Tel: 392320/1
 TLX: 20765 LE PHIBAN

Malaysia
Mecomb Malaysia SDN BHD
 (For Fluke products)
 P.O. Box 24
 46700 Petaling Jaya
 Selangor, Malaysia
 Tel: (60) 3-7743422, TLX: (784) MA37764
 FAX: (60) 3-774 3414

Philips Malaysia Snd. Bhd./
Wisma Philips
 (For Philips products)
 1st, 2nd, 3rd Floors, 3 Jalan
 SS 15/2a, P.O. Box 12163
 Subang Jaya
 47500 Petaling Jaya
 Tel: 60-3-7345511
 TLX: PHIMAL MA 25111

Malta
Fablan Enterprises
 (For Fluke products)
 20, Msida Road
 Gzira, Malta
 Tel: 513283/40216, TLX: (838) 1837

Mexico
Mexicana de Electronica
Industrial S.A. (MEXEL)
 Diagonal No. 27
 Entre Calle de Eugenia Y Ave.
 Colonia del Valle
 C.P. 03100, Mexico
 Tel: (905) 660-4323, TLX: (383) 1771038

Morocco
Oussama S.A.
 (For Fluke products)
 Angle Boulevard Emile Zola et
 Rue Rethel
 P.O. Box 2007 Casa
 Casablanca, Morocco
 Tel: (212) 24-13-38, TLX: (933) 22730 M

Somaciel
 (For Philips products)
 304 Boulevard Mohamed V,
 Casablanca 05
 Tel: 30 80 51/52
 TLX: 27021

Nepal
Associated Enterprises
 (For Fluke products)
 GPO Box 790, Pyaphal Tole
 Kathmandu, Nepal
 Tel: 13868, TLX: 2568

Netherlands
Philips Nederland
Test en Meetapparaten
 Hoevenseweg 55A
 5017 AD TILBURG
 Postbus 115
 5000 AC TILBURG
 Tel: 013-352455
 TLX: 52683

Fluke European Headquarters
 (For Fluke products)
 P.O. Box 2269
 5600 CG Eindhoven
 The Netherlands
 Tel: (40) 458045, TLX: (844) 51846
 FAX: 31-40-457515

New Zealand
Northrop Instruments & Systems Ltd.
 (For Fluke products)
 Information Technology Group
 131 Khyber Pass Road
 Private Bag, Newmarket
 Auckland 1, New Zealand
 Tel: (64) (9) 501-801, TLX: (791) 21570
 FAX: 64-9-543430

Northrop Instruments & Systems Ltd.
 (For Fluke products)
 Information Technology Group
 First Floor, Northrop Bldg.
 189-191 Willis Street
 P.O. Box 2406
 Wellington, New Zealand
 Tel: (64) (4) 856-658, TLX: (791) 3380

Northrop Instruments & Systems Ltd.
 (For Fluke products)
 Information Technology Group
 110 Mandeville Street
 P.O. Box 8388
 Christchurch, New Zealand
 Tel: (64) (3) 488-874, TLX: (791) 4801

Philips New Zealand Ltd.
Industrial & Electro-acoustic
Systems Division
 2 Wagener Place, P.O. Box 4 021
 Auckland 3, New Zealand
 Tel: (09) 894-160
 TLX: NZ 2395, FAX: (9) 862-728

Nigeria
Associated Electronic Products
(Nigeria) Ltd.
 (For Philips products)
 KM 16, Ikorodu Road, Ojota
 P.O. Box 1921
 Lagos
 Tel: 234-1-900160/69
 TLX: 21961 NG

Norway
Morgenstjerne & Co A/S
 (For Fluke products)
 Konghellegate 3
 P.O. Box 6688, Rodelokka
 Oslo 5, Norway
 Tel: (47) (2) 356110, TLX: (856) 71719
 FAX: (47) 2-381457

Norsk AI/S Philips
 (For Philips products)
 Dept. I&E, Test & Measurement
 Sandstuveien 70, P.O. Box 1
 Manglerud
 Oslo 6
 Tel: 2-680200

Oman
OHI Telecommunications
 (For Fluke products)
 P.O. Box 889
 Muscat, Oman
 Tel: (968) 603606, TLX: (926) 5052

Pakistan
International Operations
(PAK Private), Ltd.
 (For Fluke products)
 505 Muhammadi House
 I.I. Chundrigar Road
 P.O. Box 5323, Karachi, Pakistan
 Tel: (21) 221127, TLX: (952) 24494

Philips Electrical Co. of Pakistan Ltd.
 (For Philips products)
 P.O. Box 7101
 M.A. Jinnah Road
 Karachi 3
 Tel: 92-21-725772
 TLX: 2874 PHPAK PK

Paraguay
Philips del Paraguay S.A.
 (For Philips products)
 Avenida Artigas 1519
 Casilla de Correo 605
 Asuncion
 Tel: 595-21-291924
 TLX: PY 215

Peru
Importaciones y Representaciones
Electronicas S.A.
 (For Fluke products)
 Avda. Franklin D. Roosevelt 105
 Lima 1, Peru
 Tel: (51) (14) 28-8650, TLX: (394) 25663

Philips Peruana S.A.
 (For Philips products)
 Av. Alfonso Ugarte 1268
 Lima 5 or Apartado 1841
 Lima 100
 Tel: 51-14-326070
 TLX: 21678 PE PHILPER

Philippines, Republic of
Spark Radio & Electronics, Inc.
 (For Fluke products)
 Greenhills P.O. Box 610
 San Juan, Metro Manila, 3113
 Philippines
 Tel: (2) 775192, TLX: (722 or 732) 27901

Philips Industrial Development Inc.
 (For Philips products)
 2246, Pasong Tamo
 P.O. Box 911
 MCCPO Makati Riazal D
 Metro Manila
 Tel: 63-2-868951

Portugal
Decada Espectral
Equipamentos de Electronica
 (For Fluke products)
 Av. Bombeiros Voluntarios
 Lote 102B, Miraflores/Alges
 1495 Lisbon, Portugal
 Tel: (351) (1) 4103420, TLX: (832) 15515
 FAX: (351) 1-410-1844

Philips Portuguesa, S.A.R.L.,
Divisao de Sistemas Industriais
 (For Philips products)
 e Electri-Acasticc
 Outurila-Cavinaxille
 2795 Linda-A-Velha
 Tel: 2190071; TLX: 42987

Saudi Arabia
Electronic Equipment Marketing Co.
 (For Fluke products)
 P.O. Box 3750
 Riyadh, 11481 Saudi Arabia
 Tel: (928) (1) 477-1650, TLX: 401120

Singapore, Republic of
Rank O'Connor's (PTE) Ltd.
 (For Fluke products)
 O'Connor House
 98 Pasir Panjang Road
 Singapore 0511
 Republic of Singapore
 Tel: (65) 4737944, TLX: (786) RS21023

Philips Project Development (S) Pte. Ltd.
 (For Philips products)
 Lorong 1, Toa Payoh
 Singapore 1231, P.O. Box 340
 Toa Payoh Central Post Office
 Singapore 9131
 Tel: 65-3502000
 TLX: Philips RS/21375

South Africa
Protea, PNI
 (For Fluke products)
 P.O. Box 39127
 Bramley 2018
 Republic of South Africa
 Tel: (27) (11) 786-3647
 TLX: (960) 4-24409 SA
 FAX: 27-11-887-1479

South African Philips (Pty) Ltd.
 (For Philips products)
 P.O.B. 7703
 2 Herb Street
 New Doornfontein
 Johannesburg 2000
 Tel: (011) 6179111

South Korea
Philips Industries (Korea) Ltd.
 (For Philips products)
 C.P.O. Box 3680, Philips House
 260-199, Itaewon-Dong
 Yongsan-Ku
 Seoul
 Tel: 82-2-794-5011/5
 TLX: Philkor K 27291

Spain
ESSA
 (For Fluke products)
 Equipos y Sistemas S.A.
 C/Apolonio Morales, 13-B
 Madrid 16, Spain
 Tel: (34) (1) 458-0150, TLX: (831) 42856
 FAX: (34) 1-458-0150

Philips Iberica S.A.E. Dpto
 (For Philips products)
 Aparatos de Medida
 Martinez Villergas 2
 Madrid 28027
 Tel: 404-2200

Sri Lanka
Computerlink Data Systems, Ltd.
 (For Fluke products)
 331 Union Place
 Colombo, 2, Sri Lanka
 Tel: (94) (1) 28641/2, TLX: (954) 22455

Sweden

Philips Foersaeljning AB
Division Industrielektronik
 Test & Measurement
 S-115 84 Stockholm
 Tel: (08) 782 18 00

Switzerland

Traco Electronic AG
 (For Fluke products)
 Jenatschstrasse 1
 8002 Zurich
 Switzerland
 Tel: (41) (1) 201-0711, TLX: (845) 815570

Philips AG

(For Philips products)
Test-und Messtechnik
 Postfach
 CH-8027 Zurich
 Tel: (01) 4882390

Syria

Mabek (Electronics Division)
 (For Fluke products)
 P.O. Box 4238
 Damascus, Syria

Philips Moyen-Orient S.A.R.L.

(For Philips products)
 Rue Fardoss 79
 P.O. Box 2442
 Damascus
 Tel: 218605/221650
 TLX: PHISYR 411203 SY

Taiwan

Schmidt Electronics Corp.
 (For Fluke products)
 5th Floor, Cathay Min-Sheng
 Commercial Building,
 344 Min-Sheng East Road
 Taipei 104, Taiwan R.O.C.
 Tel: (886) (2) 501-3468, TLX: (785) 11111
 FAX: (886) 2-5029692

Philips Taiwan Ltd.

(For Philips products)
 150, Tun Hua North Road
 P.O. Box 22978
 Taipei
 Tel: 886-2-7120500
 TLX: 21570 PHILPEI

Tanzania

Philips (Tanzania) Ltd.
 (For Philips products)
 T.D.F.L. Building - 1st Floor
 P.O. Box 20104
 Ohio/Upanga Rd.
 Dar es Salaam
 Tel: 29571/4
 TLX: 41016

Thailand

Measuretronix Ltd.
 (For Fluke products)
 2102/63 Ramkamhaeng Road
 Bangkok 10240
 Thailand
 Tel: (66) (2) 374-2516, TLX: (788) 82796

Philips Electrical Co. of Thailand Ltd.

(For Philips products)
 283, Silom Road
 P.O. Box 961
 Bangkok 10500
 Tel: 66-2-233 6330.9
 TLX: 87327 PHILTHA TH

Tunisia

Selep S.A.R.L.
 (For Fluke products)
 6, Rue de Sparte
 Tunis - 1000 RP
 Tunisia
 Tel: (216) (1) 248093, TLX: (934) 13030

STIET

(For Philips products)
 32bis rue Ben Ghedahem
 Tunis
 Tel: 348666, TLX: 14512

Turkey

Erkman Elektronik Aletler
 (For Fluke products)
 Ticaret Anonim Sirketi
 Necatibey Cad 92/3
 Karakoy, Istanbul, Turkey
 Tel: (90) (1) 1441546, TLX: (821) 24399
 FAX: (90) 1-1497037

Turk Philips Ticaret A.S.

(For Philips products)
 Inonu Caddesi 78/80
 P.K. 504
 80074 Beyoglu-Istanbul
 Tel: 90-1-1435910
 TLX: 24192 PHTRTR

United Arab Emirates

Haris Al-Afag, Ltd.
 (For Fluke products)
 P.O. Box 8141
 Kamal Hamza Bldg.
 Traffic Police Rd.
 Dubai, U.A.E.
 Tel: (971) 4-283625, TLX: (958) 48168

Philips Middle East

(For Philips products)
 Dubai Intern. Trade Centre,
 11th Floor
 P.O. Box 9269
 Dubai
 Tel: 971-4-377000
 TLX: 46350 PMOA EM

Al-Sanani Cen. Trad. Est.

(For Fluke products)
 P.O. Box 7187
 Abu-Dhabi, U.A.E.
 Tel: (971) (2) 821370
 TLX: (958) 23966

Uruguay

Coasin Uruguay S.A.
 (For Fluke products)
 Libertad 2529
 Casilla de Correo 1400
 Montevideo, Uruguay
 Tel: (598) (2) 789015, TLX: (398) UY23010

Industrias Philips del Uruguay S.A.

(For Philips products)
 Av. Uruguay 1287
 Casilla de Correo 294
 Montevideo
 Tel: 919000
 TLX: PHILURU UY 22296

Venezuela

Coasin C.A.
 (For Fluke products)
 Calle 9 Con Calle 4, Edif Edinurbi
 Apartado de Correos NR-70.136
 Los Ruices
 Caracas 1070-A, Venezuela
 Tel: (58) 2-241-0309, TLX: (395) 21027

Inds. Venezolanas Philips. S.A.

(For Philips products)
 Av. Francisco de Miranda,
 Urb. La Carlota,
 Edf. Centro Empresarial Parque del Este
 Apartado 1167
 Caracas 1010-A
 Tel: 58-2-203,71111
 TLX: 25267 IVPSA VC

Zaire

Philips Electronics S.A.R.L.
 (For Philips products)
 137, Boulevard du 30 juin
 B.P. 16636
 Kinshasa
 Tel: 31693, TLX: 21078 KINSHASA

Zambia

Philips Electrical Zambia Ltd.
 (For Philips products)
 Mwembeshi Road
 P.O. Box 1878
 Lusaka
 Tel: 218511/218701
 TLX: ZA 41220

Zimbabwe

Philips Electrical (Pvt.) Ltd.
 (For Fluke products)
 62 Mutare Road
 P.O. Box 994
 Harare
 Tel: 47211/48031
 TLX: 2236

For countries not listed above:**Philips Export B.V.**

I&E Export
Test & Measuring
 Building HVW-3
 P.O. Box 218
 5600 MD Eindhoven
 The Netherlands
 Tel: +31 40 324842
 TLX: 35000 phtc nl
 FAX: +31 40 324898

TECHNICAL SERVICE CENTERS

U.S. Service Locations

California

Fluke Technical Center
46610 Landing Parkway
Fremont, CA 94538
(415) 651-5112

Fluke Technical Center
16969 Von Karman Ave., Suite 100
Irvine, CA 92714
(714) 863-9031

Colorado

Fluke Technical Center
14180 East Evans Ave.
Aurora, CO 80014
(303) 695-1000

Florida

Fluke Technical Center
940 N. Fern Creek Avenue
Orlando, FL 32803
(305) 896-4881

Illinois

Fluke Technical Center
1150 W. Euclid Ave.
Palatine, IL 60067
(312) 705-0500

Maryland

Fluke Technical Center
5640 Fishers Lane
Rockville, MD 20852
(301) 770-1576

New Jersey

Fluke Technical Center
West 75 Century Road
P.O. Box 930
Paramus, NJ 07653-0930
(201) 599-9500

Texas

Fluke Technical Center
1801 Royal Lane, Suite 307
Dallas, TX 75229
(214) 869-0311

Washington

Fluke Technical Center
6920 Seaway Blvd.
Everett, WA 98206
(206) 356-5560

International

Argentina

Coasin S.A.
(For Fluke products)
Virrey del Pino 4071
Buenos Aires, Argentina
Tel: 522-5248

Philips Argentina S.A.
(For Philips products)
Casilla Correo 3479
1000 Buenos Aires
Tel: 542-2411/51

Australia

Elmeasco Instruments Pty Ltd.
(For Fluke products)
P.O. Box 30
Concord, N.S.W. 2137
Australia
Tel: 736-2888

Elmeasco Instruments Pty. Ltd.
(For Fluke products)
P.O. Box 623
Ringwood, VIC 3134
Australia
Tel: 879-2322

Elmeasco Instruments Pty. Ltd.
(For Fluke products)
PO Box 274
Salisbury, Queensland 4107
Australia
Tel: 875-1444

Philips Scientific &
Industrial Equip. Div.
(For Philips products)
Centre Court 25-27 Paul St.
North Ryde
Sydney N.S.W. 2113
Tel: 88 88 222

Austria

Walter Rekirsch Elektronische
Geräte GmbH & Co.
(For Fluke products)
Vertrieb KG
Obachgasse 28
1220 Vienna, Austria
Tel: 253626

Oesterreichische Philips
Industrie GmbH
(For Philips products)
Abteilung Industrie Elektronik
Triesterstrasse 64
A-1100 Wien
Tel: 645521

Algeria

Bureau de Liaison Philips
(For Philips products)
24 bis rue Bougainville
Ti Mouradia, Alger
Tel: 56 56 72

Antillen

Philips Antillana N.V.
(For Philips products)
P.O. Box 523
Willemstad, Curacao
Tel: 414071/74

Bangladesh

Philips Bangla Desh Ltd.
(For Philips products)
P.O. Box 62
Ramna, Dhaka
Tel: 234280

Belgium

N.V. Philips & Mble Assoc.
Scientific & Industrial Div
70 Rue des Deux Gares
Brussels, Belgium
Tel: 2-525 6111

Brazil

Hi-Tek Electronica Ltda.
(For Fluke products)
Al. Amazonas 422
Alphaville, Barueri
CEP 06400 Sao Paulo, Brazil
Tel: 421-5477

Industias Brasileiras
Philips Ltd.
(For Philips products)
Av. Eng. Luiz Carlos Berrini
3009-7 and. CEP 04571
Sao Paulo S.P.
Tel: 241.1611

Canada

Fluke Electronics Canada Inc.
400 Britannia Rd.
Unit #1
Mississauga, Ontario L4Z 1Y9
Tel: 416-890-7600

Fluke Electronics Canada, Inc.
(For Fluke products)
1255 Trans Canada Highway
Suite 130
Dorval, Quebec H9P 2V4
Tel: 514-685-0022

Fluke Electronics Canada Inc.
(For Fluke products)
101, 1144 29th Ave. N.E.
Calgary, Alberta T2E 7P7
(403) 291-5215

Chile

Intronica Chile Ltda.
(For Fluke products)
Casilla 16228
Santiago 9, Chile
Tel: 2321886

Philips Chilena S.A.
(For Philips products)
Casilla Postal 2687
Santiago de Chile
Tel: 770038

China, Peoples Republic of
Instrimpex - Fluke Service Center
(For Fluke products)
57, Xisi Dong Da Jie
Xicheng-qu
P.O. Box 9085
Beijing
People's Republic of China
Tel: 65-7281

Colombia

Sistemas E Instrumentacion, Ltda.
(For Fluke products)
Carrera 13, No. 37-43, Of. 401
Ap. Aereo 29583
Bogota DE, Colombia
Tel: 232-4532

Denmark

Tage Olson A/S
(For Fluke products)
Ballerup, Byveg 222
2750 Ballerup
Denmark
Tel: 658111

Philips Elektronik Systemer A/S
(For Philips products)
Afd. Industri & Forskning
Prags Boulevard 80-P.B. 1919
DK-2300-Koebenhavn S.
Tel: 572222

Ecuador

Protoco Coasin Cia., Ltda.
(For Fluke products)
P.O. Box 228-A
Ave. 12 de Octubre 2285 y
Orellana
Quito, Ecuador
Tel: 526759

Philips Ecuador S.A.
(For Philips products)
Casilla 343
Quito
Tel: 396100

Egypt and Sudan

Electronic Engineering
Liaison Office
(For Fluke products)
P.O. Box 2891 Horreya
11361 Heliopolis
Cairo, Egypt
Tel: 695705

Philips Egypt Branch
of P.M.O.B.V.
P.O. Box 1687
10 Abadel Rahman el Rafei St.
Dokki, Cairo
Tel: 490922

Ethiopia

Philips Ethiopia
(Priv. Ltd. Co.)
(For Philips products)
Ras Aveve Areguay Avenue
P.O. Box 2565
Addis Ababa
Tel: 148300

Finland

Instrumentarium Elektroniikka
(For Fluke products)
P.O. Box 64, Viihka 1
02631 ESPOO 63
Finland
Tel: 358-0-5281

OY Philips AB
(For Philips products)
Kaivokatu 8
P.O. Box 255
00101 Helsinki 10
Tel: 1-7271

France

M.B. Electronique S.A.
(For Fluke products)
608, Rue Fourny
P.O. Box 31
78530 BUC, France
Tel: 9568131

S.A. Philips Industrielle
et Commerciale
Science et Industry
(For Philips products)
105 Rue de Paris
93002 Bobigny
Tel: 48301111

Germany (F.R.G.)

Philips GmbH
Unternehmensbereich Elektronik
für Wissenschaft und Industrie
Werk für Messtechnik
Oskar-Messter-Straße 18
8045 Ismaning
Deutschland
Tel: (089) 96050

Great Britain

Philips Scientific Test
& Measuring Division
(For Fluke products)
Colonial Way
Watford Herts WD2 4TT
United Kingdom
Tel: 0923-240511

Pye Unicam Ltd.
(For Philips products)
York Street
Cambridge CB1 2PX
Tel: 923-40511

Greece

Hellenic Scientific
Representations Ltd.
(For Fluke products)
11 Vrassida Street
Athens 612, Greece
Tel: 7211140

Philips S.A. Hellenique
(For Philips products)
P.O. Box 153
54 Ave Syngrou
Athens
Tel: 9215311

Hong Kong

Schmidt & Co (H.K.) Ltd.
(For Fluke products)
18th Fl., Great Eagle Centre
23 Harbour Road
Wanchai, Hong Kong
Tel: 8330-222

Philips Hong Kong Ltd.
(For Philips products)
P.O.B. 2108
27-29 Floor
Hopewill Centre
17, Kennedy Road
Hong Kong
Tel: 5-283298

Iceland

Heimelistaeki SF
(For Philips products)
Saetun 8
Reykjaavik
Tel: 24000

India

Hinditron Services Pvt. Ltd
(For Fluke products)
1st Floor, 17-B, Mahal
Industrial Estate
Mahakali Road Andheri East
Bombay 400 093, India
Tel: 6300043

Hinditron Services Pvt. Ltd.
(For Fluke products)
33/44A Raj Maha Villas Extn.
8th Main Road
Bangalore 560 080, India
Tel: 363139

Hinditron Services Pvt. Ltd.

(For Fluke products)
15 Community Centre
Panchshila Park
New Delhi, 110 017, India
Tel: 6433675

Hinditron Services Pvt. Ltd.

Field Service Center
(For Fluke products)
Emerald Complex 1-7-264
5th Floor
114 Sarojini Devi Road
Secunderabad 500 003, India
Tel: 821117

Peico Electronic & Electricals Ltd.

(For Philips products)
Shivsagar Estate
Block "A"
Dr. Annie Besant Road
P.O.B. 6598
Worli, Bombay 400 018
Tel: 4921500

Indonesia

P.T. Lamda Triguna
(For Fluke products)
P.O. Box 6/JATJG
Jakarta 13001, Indonesia
Tel: 8195365

P.T. Daeng Brothers
(For Philips products)
Centre Point Bldg - 3rd Floor
Jl Jend. Gatot Suggroto
Kav. 35/36
P.O. Box 41 Tebet
Jakarta 12950
Tel: 517335

Iran

Philips Iran Ltd.
(For Philips products)
P.O.B. 1297
Teheran
Tel: 372081/5

Iraq

Philips Iraq W.L.L.
(For Philips products)
Munir Abbas Building
4th Floor South Gate
P.O. Box 5749
Baghdad
Tel: 880409

Ireland

Philips Electrical
(Ireland) Ltd.
(For Philips products)
Newstead
Clonskeagh, Dublin 14
Tel: 693355

Israel

R.D.T. Electronics
Engineering Ltd.
P.O. Box 43137
Tel Aviv 61430
Israel
Tel: 483211

Italy

Sistrel S.p.A.
(For Fluke products)
Via Pelizza da Volpedo 59
20092 Cinisello Balsamo
Milan, Italy
Tel: 6181893

Philips S.p.A.
(For Philips products)
Sezione S & I T & M Dept.
Viale Elvezia 2
20052 Monza
Tel: (039) 3635.1

Japan

John Fluke Mfg. Co., Inc.
Japan Branch
(For Fluke products)
Sumitomo Higashi Shinbashi Bldg.
1-1-11 Hamamatsucho
Minato-ku, Tokyo 105, Japan
Tel: 434-0181

Nihon Philips Corporation

(For Philips products)
Shuwa Shinagawa Building
26-38 Takanawa 3-chrome
Minato-ku, Tokyo 108
Tel: 4485511

Kenya

Philips (Kenya) Ltd.
(For Philips products)
P.O. Box 30554
Nairobi
Tel: 557999

Korea

Myoung Corporation
(For Fluke products)
Yeo Eui Do P.O. Box 14
Seoul, Korea
Tel: 784-9942

Philips Elelectronics (Korea) Ltd.

(For Philips products)
C.P.O. Box 3680
Seoul, Korea
Tel: 794-5011/5

Lebanon

Philips Middle East S.A.R.L.
(For Philips products)
P.O. Box 11-670
Beirut
Tel: 285748/9

Malaysia

Mecomb Malaysia Sdn. Bhd.
(For Fluke products)
P.O. Box 24
46700 Petaling Jaya
Selangor, Malaysia
Tel: 774-3422

Electrnic System (Malaysia)

Sdn. Bhd.
(For Philips products)
Resourse Plaza
No. 4 Persiaran Barat
P.O. Box 12163
Petaling Jaya
Selangor, Kuala Lumpur
Tel 554511/24

Mexico

Mexicana de Electronica
Industrial,
S.A. (Mexel)
(For Fluke products)
Diagonal No. 27
Entre Calle de Eugenia Y Ave
Colonia del Valle
C.P. 03100, Mexico
Tel: 660-4323

Apesa Electronica S.A. de C.V.
(For Philips products)
Apartado Postal 213
C.P. 50140
Toluca Edo de Mexico

Morocco

S.A.M.T.E.L.
(For Philips products)
2 Rue de Bapaume
Casablanca
Tel: 243050

Netherlands

Philips Nederland
Test & Meetapparaten
(For Fluke products)
Hoevensweg 55A,
5017 AD Tilburg
Postbus 115, 5000 AC Tilburg
Nederland
35 24 55

Philips Nederland B.V.

(For Philips products)
Boschdijk 525
Gebouw VB
5600 MD Eindhoven
Tel: 782808

New Zealand

Northrop Instruments
& Systems Ltd.
(For Fluke products)
459 Kyber Pass Road,
Private Bag, Newmarket
Auckland 1, New Zealand
Tel: 501-801

Northrop Instruments & Systems Ltd.

(For Philips products)
First Floor, Northrop Bldg.
189-191 Willis Street
P.O. Box 2406
Wellington, New Zealand
Tel: 856-658

Philips Electrical Ind. Ltd.

(For Philips products)
Scientific & Industrial Div
68-86 Jervois Quay
P.O. Box 2097
Wellington C1
Tel: 735735

Nigeria

Associated Electronic Products
(Nigeria) Ltd.
(For Philips products)
Km. 16 Ikorodu Road
Ojota
P.O. Box 1921
Lagos
Tel: 932825

6B/Sales and Service Centers

Norway

Morgenstjerne & Co. A/S
(For Fluke products)
Konghellegate 3
P.O. Box 6688, Rodelokka
Oslo 5, Norway
Tel: 356110

Norsk Akieselskap
Philips Dept.
Industry and
Telecommunication
Sandstuveien 70
P.O. Box 1
Manglerud
Oslo 6
Tel: 2-680200

Pakistan

Pak International Operations
(For Fluke products)
505 Muhammadi House
I.I. Chundrigar Road
P.O. Box 5323
Karachi Pakistan
Tel: 221127/239052

Philips Electrical Industries
of Pakistan Ltd.
(For Philips products)
Philips Markaz
M.A. Jinnah Road
P.O. Box 7101
Karachi 3, Pakistan
Tel: 725772/9

Paraguay

Philips del Paraguay S.A.
(For Philips products)
Av. Artigas 1497
Casilla Correo 605
Asuncion
Tel 291924

Peru

Importaciones Y Representaciones
Electronicas S.A.
(For Philips products)
Avda. Franklin D. Roosevelt 105
Lima 1, Peru
Tel: 288650

Philips Peruana S.A.
(For Philips products)
Av. Alfonso Ugarte 1268
Apartado 1841
Lima
Tel: 32-6070

Philippines

Spark Radio and Electronics Corp.
(For Fluke products)
Greenhills P.O. Box 610
San Juan Metro-Manila Zip, 3113
Philippines
Tel: 63-2-775192

Philips Industrial Development Inc.
(For Philips products)
2246 Pasong Tamo
Makati, Metro Manila
Tel: 868951

Portugal

Decada Espectral
(For Fluke products)
Equipamentos de Electronica e
Cientificos, SARL.
Av. Bombeiros Voluntarios,
Lote 102B
Miraflores/Alges
1495 Lisboa, Portugal
Tel: 2103420

Philips Portuguesa S.A.R.L.
(For Philips products)
Av. Eng. Duarte Pacheco
Appartado 1331
Lisbon-1
Tel: (019) 683121

Singapore

Rank O'Connor's Singapore
(PTE) Ltd.
(For Fluke products)
98 Pasir Panjang Road
Singapore 0511
Republic of Singapore
Tel: 4737944

Philips Project Development
(S) Pte. Ltd.
(For Philips products)
Lorong 1
Toa Payoh
P.O. Box 340
Singapore 1231
Tel: 2538811

South Africa

Fluke S.A. (Pty) Ltd.
P.O. Box 39127
Bramley 2018
Republic of South Africa
Tel: 786-3647

South African Philips
(Pty) Ltd.
(For Philips products)
P.O.B. 7703
2, Herb Street
New Doornfontein, Johannesburg
2000
Tel: 786-3647

Spain

Equipos Y Sistemas S.A. (ESSA)
(For Fluke products)
C/Apolonio Morales, 13B
Madrid 16, Spain
Tel: 4580150

Philips Iberica S.A.E.
(For Philips products)
Dpto Aparatos de Medida
Marinez Villergas Z Madrid 28027
Tel: 404-2200

Sweden

Svenska A.B. Philips
Div. Industrielektroik
Avd. Matinstrument
11584 Stockholm
Tel: 782-1800

Switzerland

Traco Electronic AG
(For Philips products)
Jenatschstrasse 1
8002 Zurich
Switzerland
Tel: 2010711

Philips AG
(For Philips products)
S & I Equipment
Allmendstasse 140
Postfach 670
CH-8027 Zurich, Switzerland
Tel: 488221

Syria

Philips Moyen-Orient S.A.
(For Philips products)
Rue Fardoss 79
B.P. 2442 Damascus
Tel 221650

Taiwan

Schmidt Electronics Corp.
(For Fluke products)
5th Floor, Cathay Min-Sheng
Commercial Building
344 Min-Sheng East Road
Taipei, Taiwan, R.O.C.
Tel: 5013468

Yung Kang Trading Co. Ltd.
(For Philips products)
11th Floor CTS Building
102 Kuang Fu South Road
P.O.Box 1467
Taipei
Tel: 752-7421

Tanzania

Philips (Tanzania) Ltd.
(For Philips products)
P.O. Box 20104
Dar es Salaam
Tel: 29571

Thailand

Measuretronix Ltd.
(For Fluke products)
2102/63 Ramkamhaeng Rd.
Bangkok, 10240 Thailand
Tel: 3742516

Philips Electrical Company
of Thailand Ltd.
(For Philips products)
Electronic and Communication
Systems Dept.
283 Silom Road
P.O. Box 961
Bangkok 10
Tel: 233-63330/9

Tunisia

S.T.I.E.T.
(For Philips products)
32 bis
Rue Ben Ghedhahem
Tunis
Tel: 244268

Turkey

Erkman Elektronik Aletler
(For Fluke products)
Ticaret Anonim Sirketi
Necatiby Cad 92/3
Karakoy, Istanbul, Turkey
Tel: 441546

Turk Philips Ticaret A.S.
(For Philips products)
Posta Kutusu 504
Beykoglu Istanbul
Tel: 1435910

United Arab Emirates

Philips Middle East b.v.
(For Philips products)
Dubai Int'l Trade Centre
Level 11
P.O. Box 6269
Dubai
Tel: 377000

Uruguay

Coasin Uruguaya S.A.
(For Fluke products)
Casilla de Correo 1400
Libertad 2529
Montevideo, Uruguay
Tel: 789015

Industrias Philips del Uruguay
(For Philips products)
Avda Uruguay 1287
Casilla de Correo 294
Montevideo
Tel: 915641

Venezuela

Coasin C.A.
(For Fluke products)
Calle 9 Con Calle 4
Edif. Edinurbi
Apartado de Correos Nr-70 136
Los Ruices
Caracas 1070-A, Venezuela
Tel: 241-0309

Industias Venezolanas
Philips S.A.
(For Philips products)
Av Ppal de los Ruices
Apartado Postal 1167
Caracas
Tel: 239-3811

Zaire

S.A.M.E. s.z.r.l.
(For Philips products)
B.P. 16636
Kinshasa
Tel: 31693

Zambia

Philips Electrica Zambia Ltd.
(For Philips products)
Mwembeshi Road
P.O. Box 31878
Lusaka
Tel: 218511

Zimbabwe

Philips Electric (Pvt.) Ltd.
(For Philips products)
P.O. Box 994
62 Umtali Road
Beverley, Harare
Tel: 47211

Appendix 6C
Module Revision Information

INTRODUCTION

As changes and improvements are made to the instrument, they are identified by incrementing the revision letter marked on the affected PCA.

These changes are documented on supplemental change/errata sheets which, when applicable, are inserted at the front of the manual. To identify the configuration of the PCAs used in your instrument, refer to the revision letter marked on each PCA.

6C/Module Revision Information

Module Revision Information

Ref	Assembly Name	Fluke Part No.	Revision Level
A1	Main PCA	755520	C2
A2	Display IF PCA	767947	C1
A3	Keypad	755454	D
A4	Video Controller PCA	755553	C1
A5	Probe PCA	755561	E
A6	Clock Module PCA	755579	B
A7	I/O Module (Main) PCA	755587	C
A8	I/O Module (Top) PCA	768747	A2
A9	Probe I/O PCA	768788	G
A10	Multi-Function IF PCA	768721	A1
A11	I/O Connector PCA	767996	A
A16	512K RAM Module	809079	A
-008	Real-Time Clock PCA	768721	A1

Section 7
Schematic Diagrams

TABLE OF CONTENTS

FIGURE	TITLE	PAGE
7-1.	A1 Main PCA	7-3
7-2.	A2 Display Interface PCA	7-7
7-3.	A3 Keypad PCA	7-9
7-4.	A4 Video Controller PCA	7-10
7-5.	A5 Probe PCA	7-12
7-6.	A6 Clock Module PCA	7-13
7-7.	A7 I/O Module (Main) PCA	7-14
7-8.	A8 I/O Module (Top) PCA	7-16
7-9.	A9 Probe I/O PCA	7-17
7-10.	A10 Multi-Function Interface PCA*	7-19
7-11.	A11 I/O Connector PCA	7-20
7-12.	A12 DIP Clip Module (Half)**	7-21
7-13.	A13 DIP Clip Module (Full)	7-22
7-14.	A14 Calibration Module PCA	7-23
7-15.	A16 512K RAM Module	7-24
7-16.	A19 Monochrome Monitor, Block Diagram	7-25
7-17.	-013 Programmer's Keyboard, Block Diagram	7-25
7-18.	Interconnect Diagram, 9100A	7-26
7-19.	Interconnect Diagram, 9105A	7-27

* A10 schematic also used with -008 Real-Time Clock PCA

** A12 schematic also used with A15 Flying Lead Module

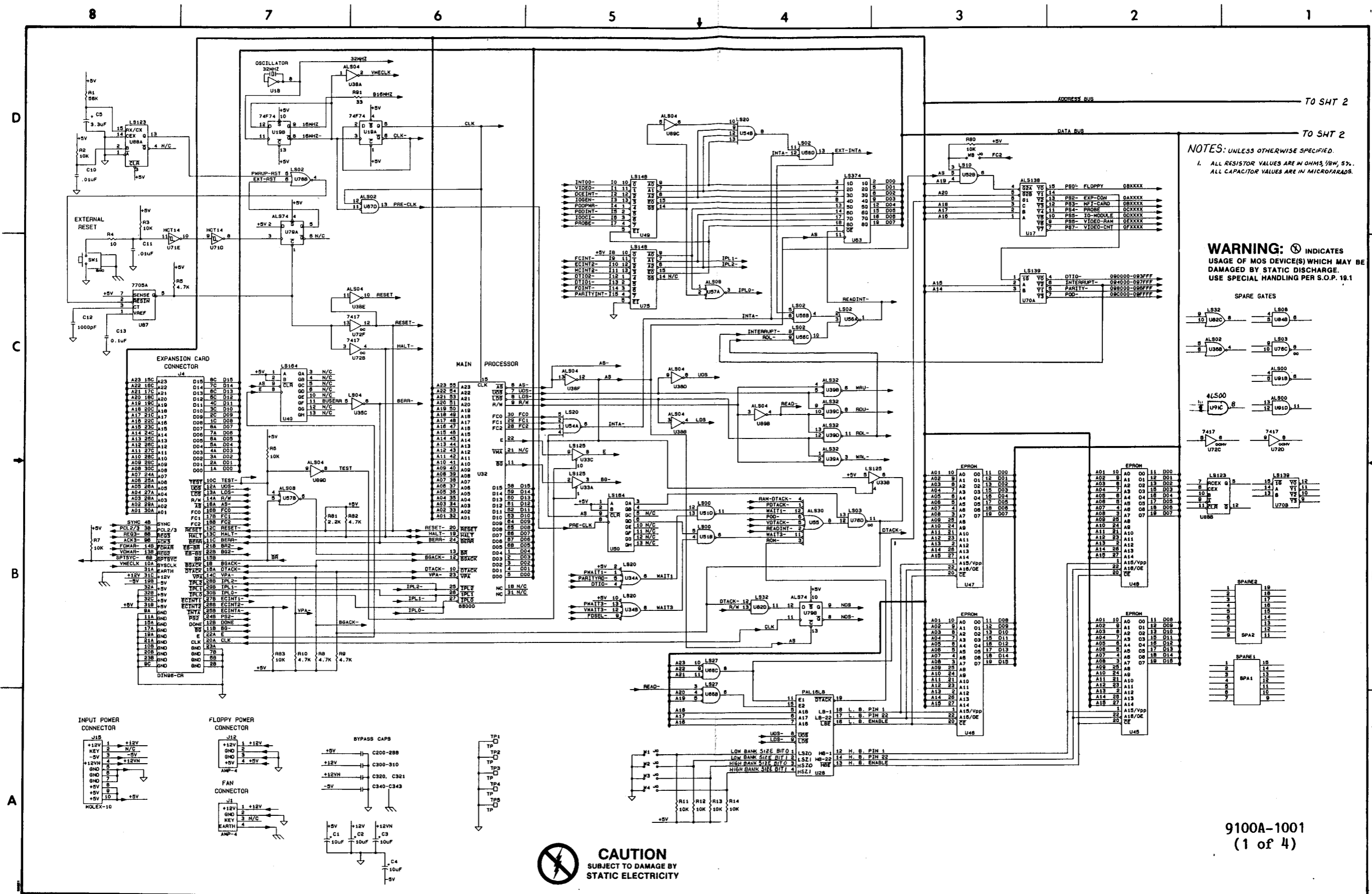

NOTES: UNLESS OTHERWISE SPECIFIED.
 1. ALL RESISTOR VALUES ARE IN OHMS, /5W, 5%.
 ALL CAPACITOR VALUES ARE IN MICROFARADS.

WARNING: ⊗ INDICATES USAGE OF MOS DEVICE(S) WHICH MAY BE DAMAGED BY STATIC DISCHARGE. USE SPECIAL HANDLING PER S.O.P. 19.1

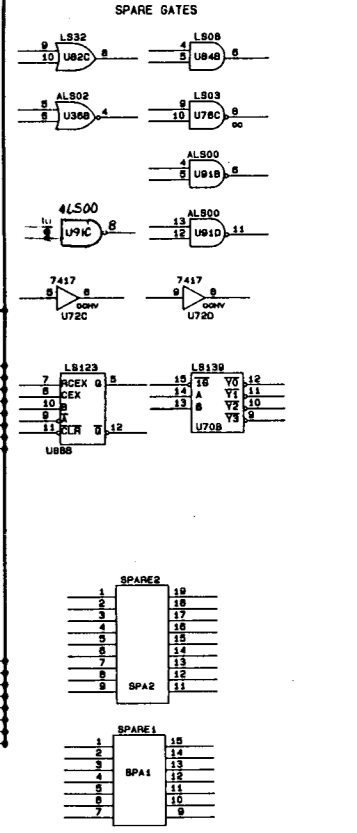

9100A-1001
(1 of 4)

CAUTION
 SUBJECT TO DAMAGE BY
 STATIC ELECTRICITY

Figure 7-1. A1 Main PCA

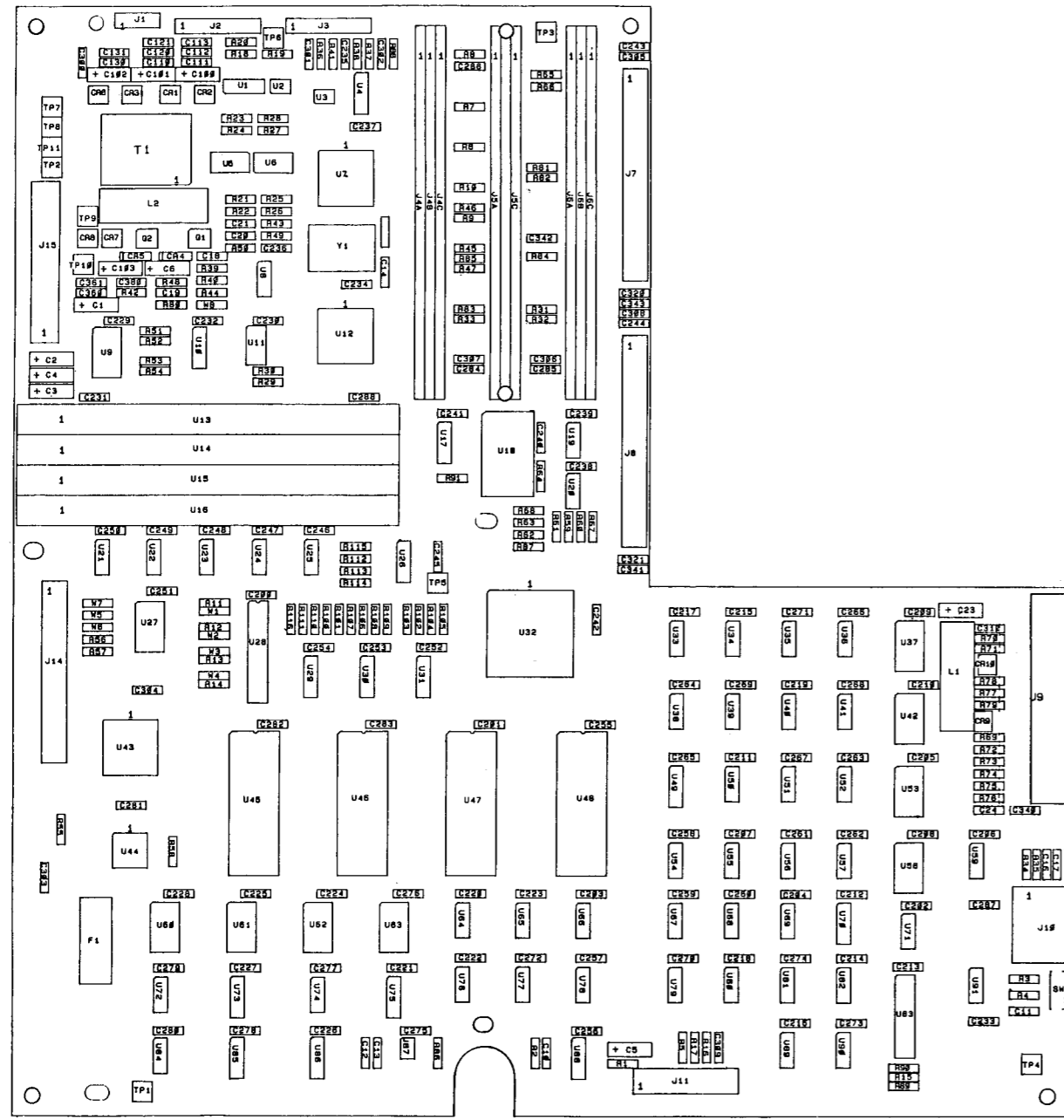

9100A-1601

CAUTION
SUBJECT TO DAMAGE BY
STATIC ELECTRICITY

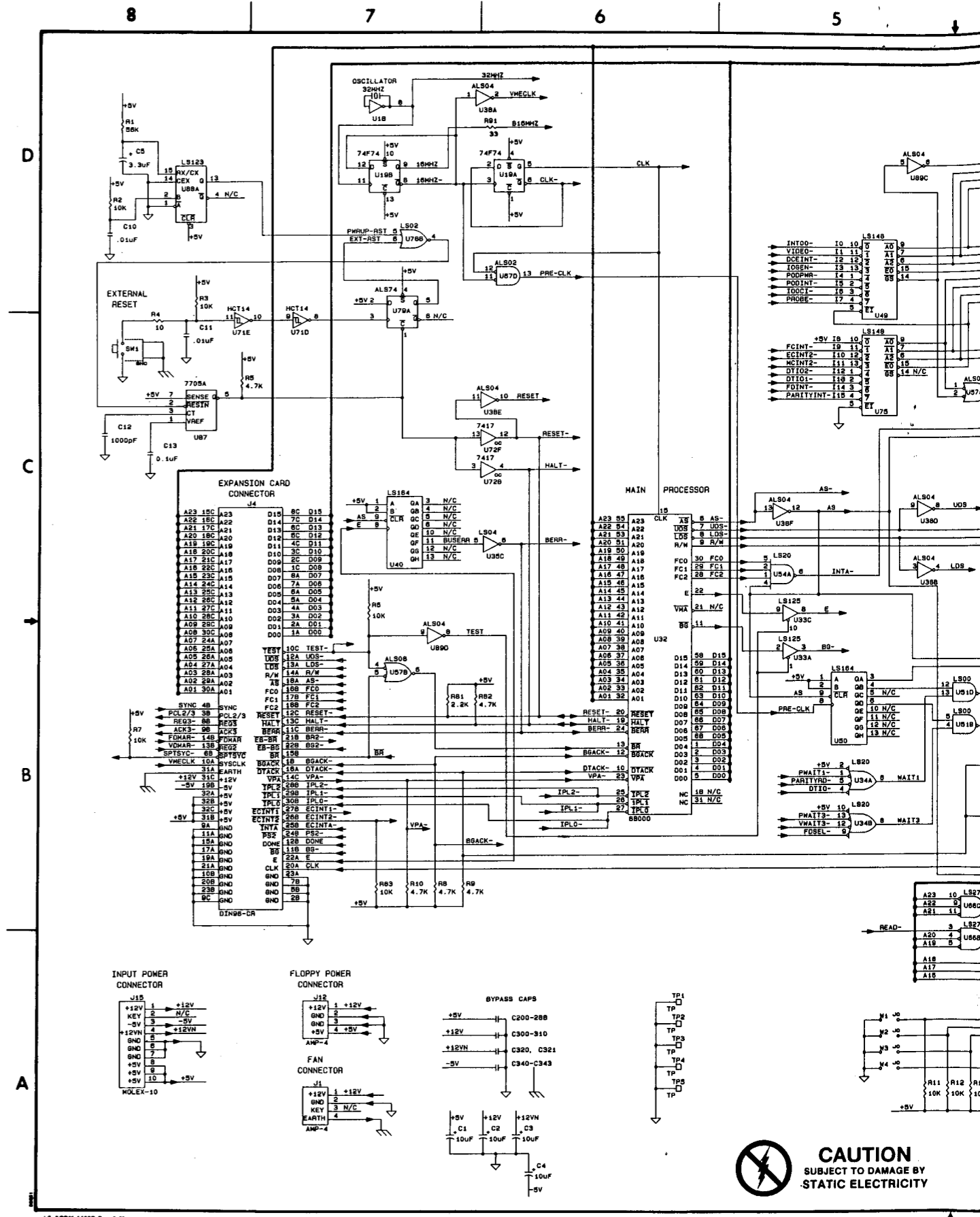

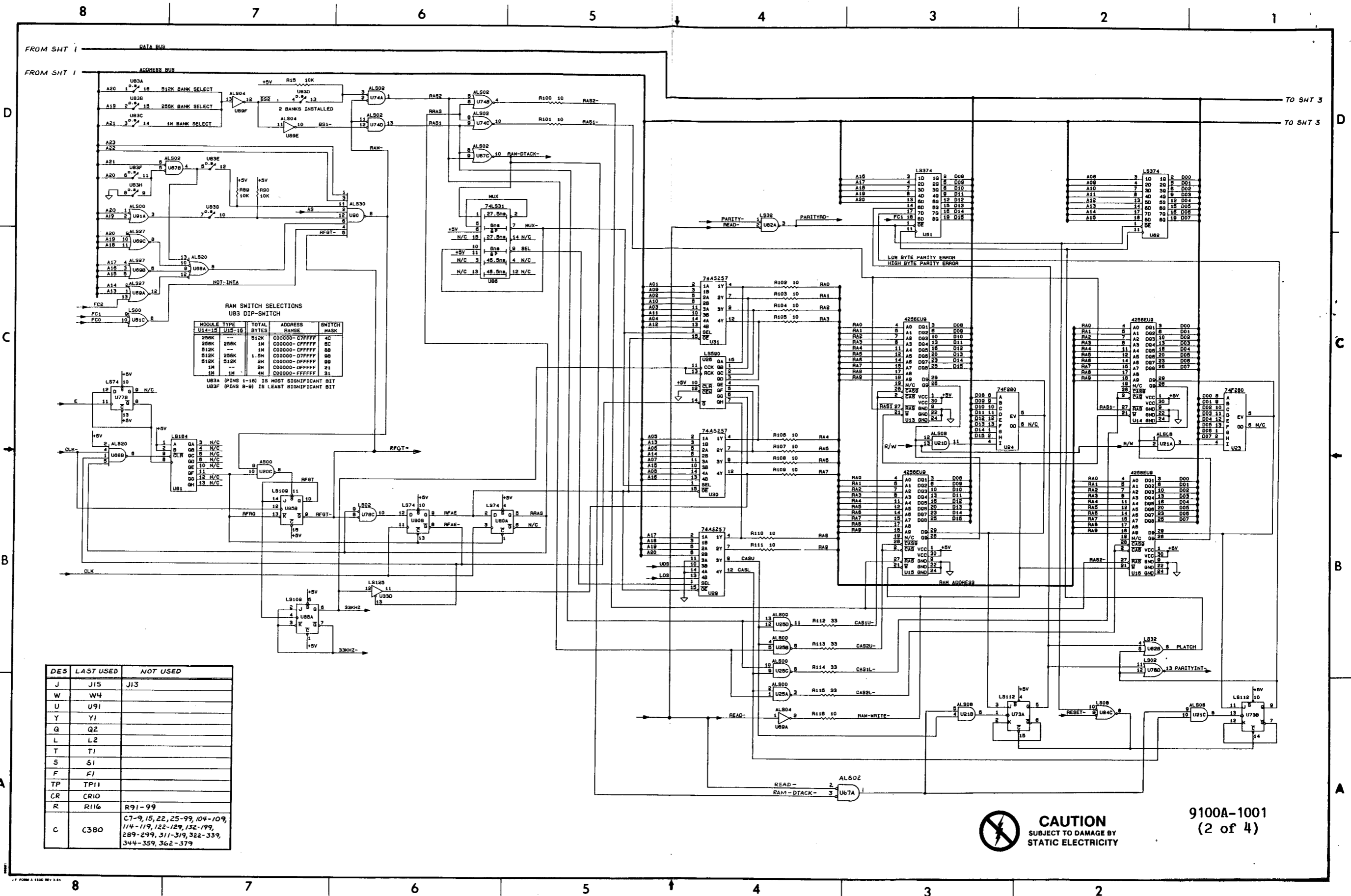
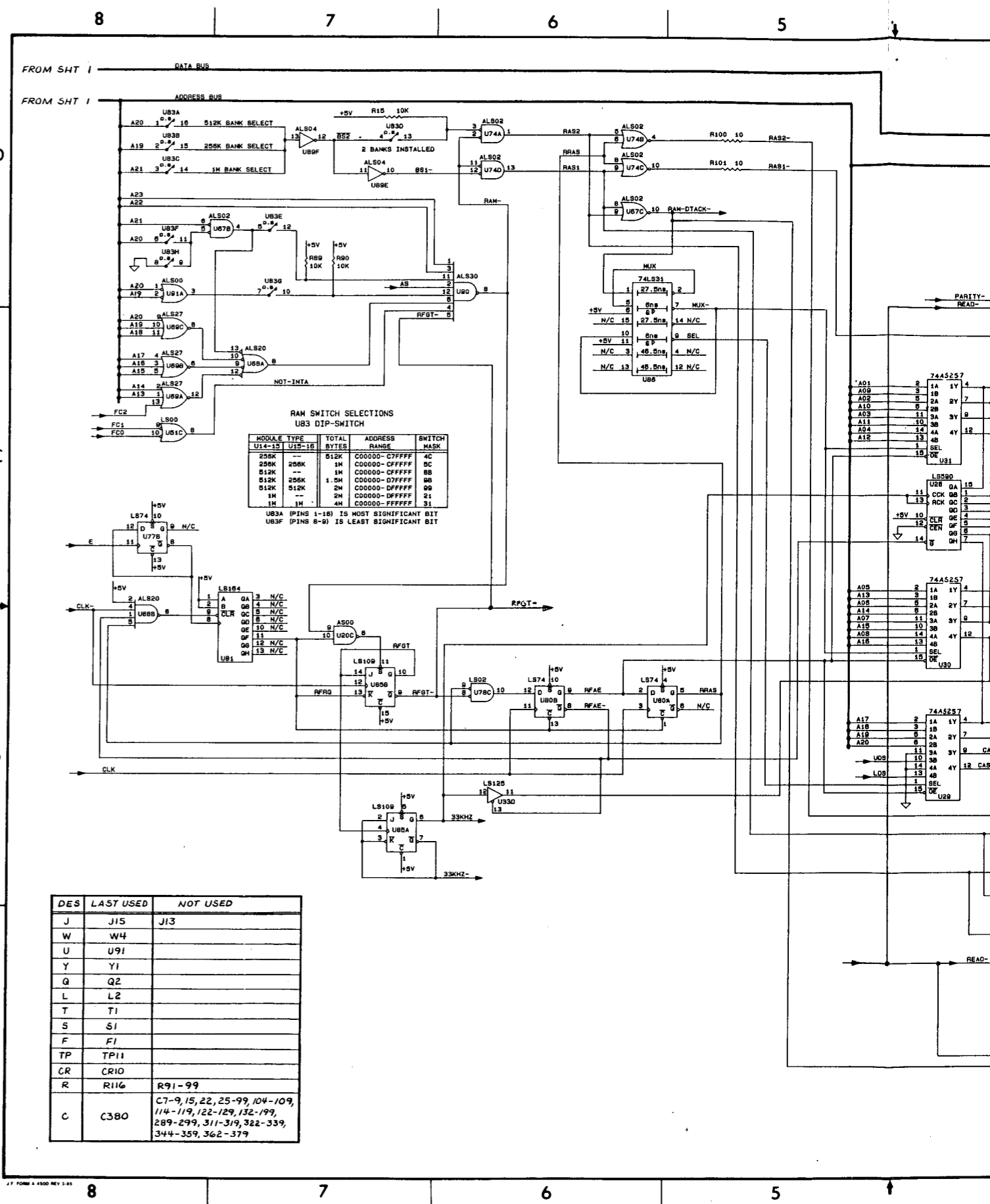
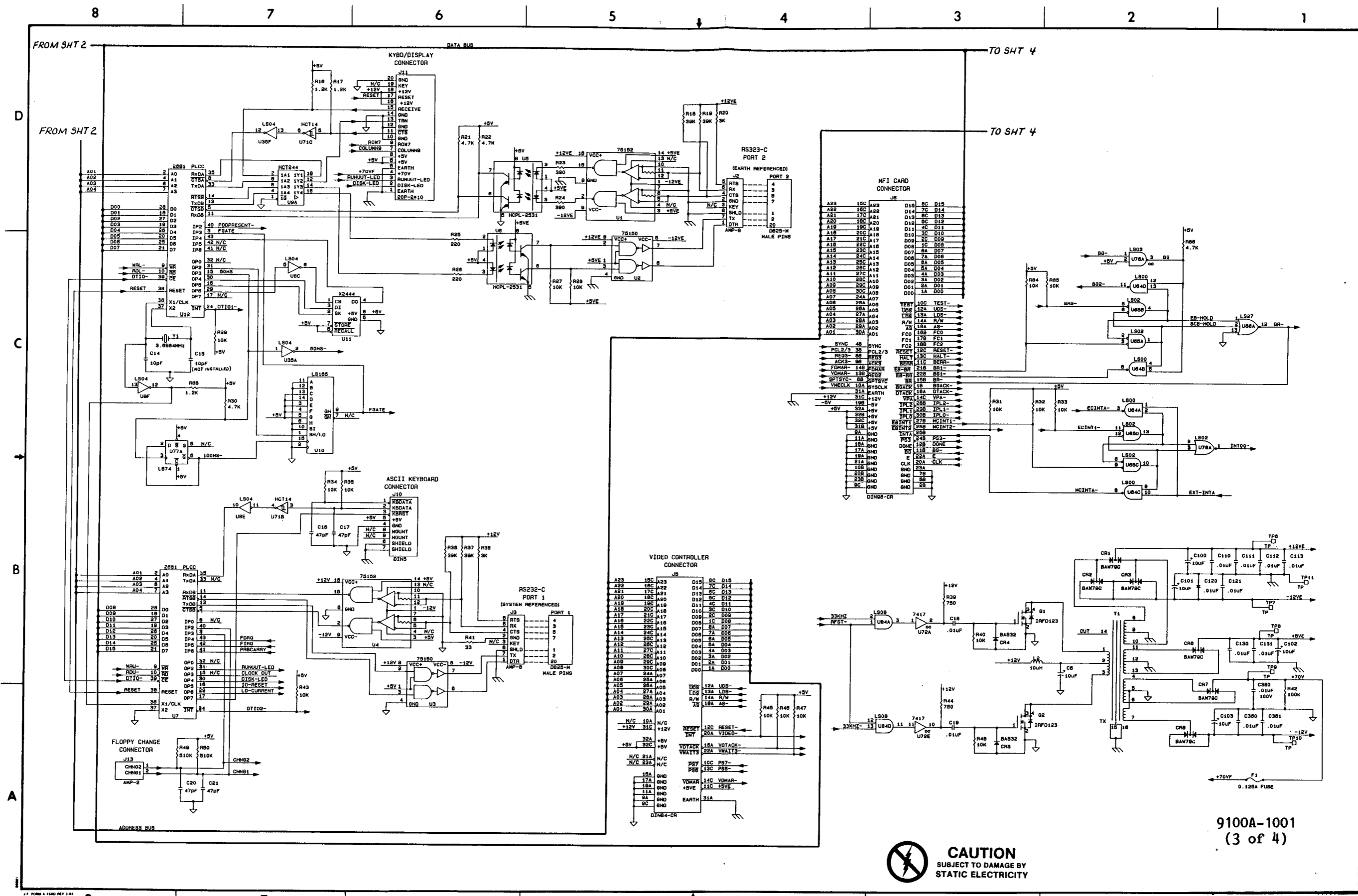

Figure 7-1. A1 Main PCA (cont.)

CAUTION
SUBJECT TO DAMAGE BY
STATIC ELECTRICITY

9100A-1001
(2 of 4)





CAUTION
SUBJECT TO DAMAGE BY
STATIC ELECTRICITY

9100A-1001
(3 of 4)

Figure 7-1. A1 Main PCA (cont.)

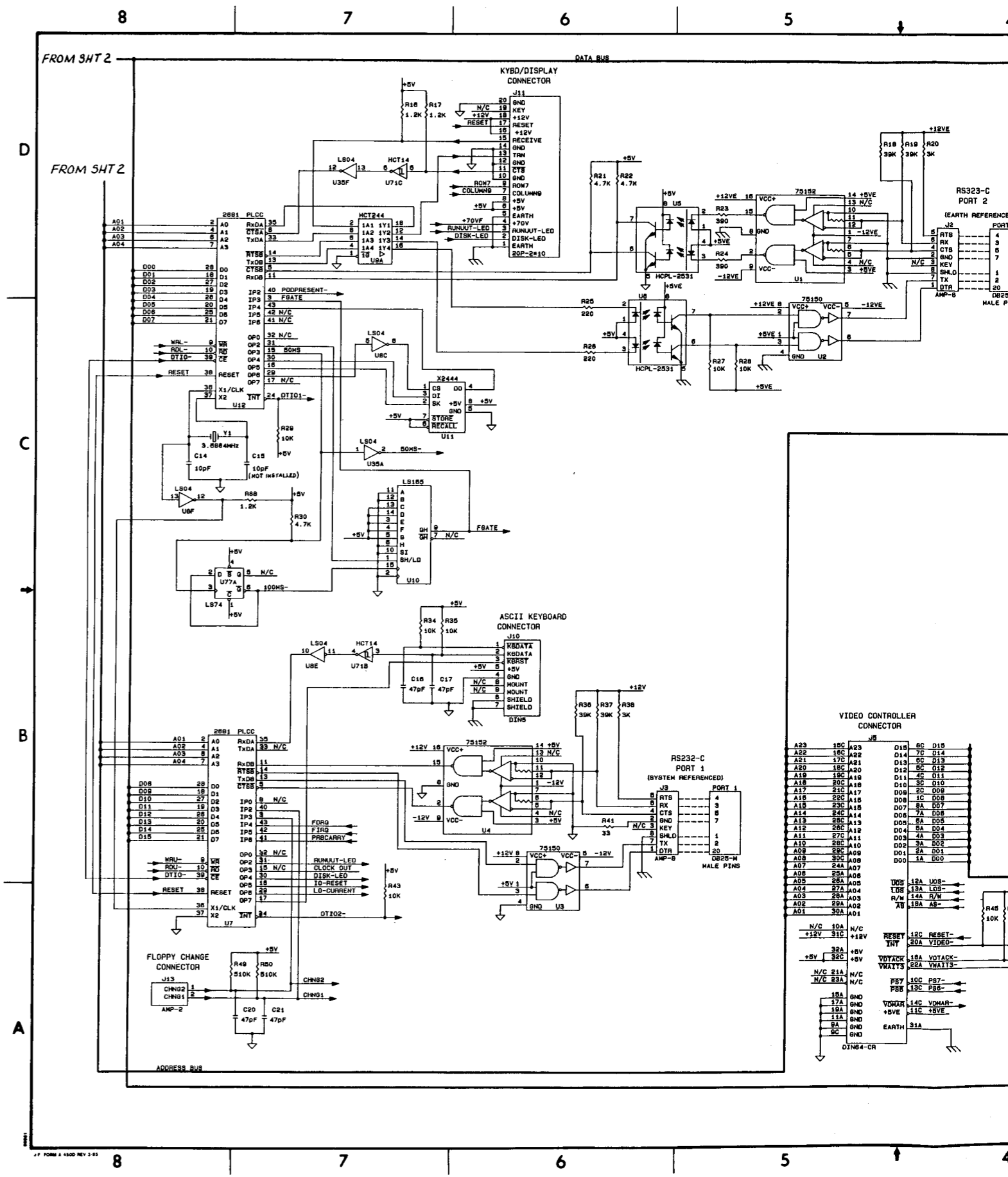

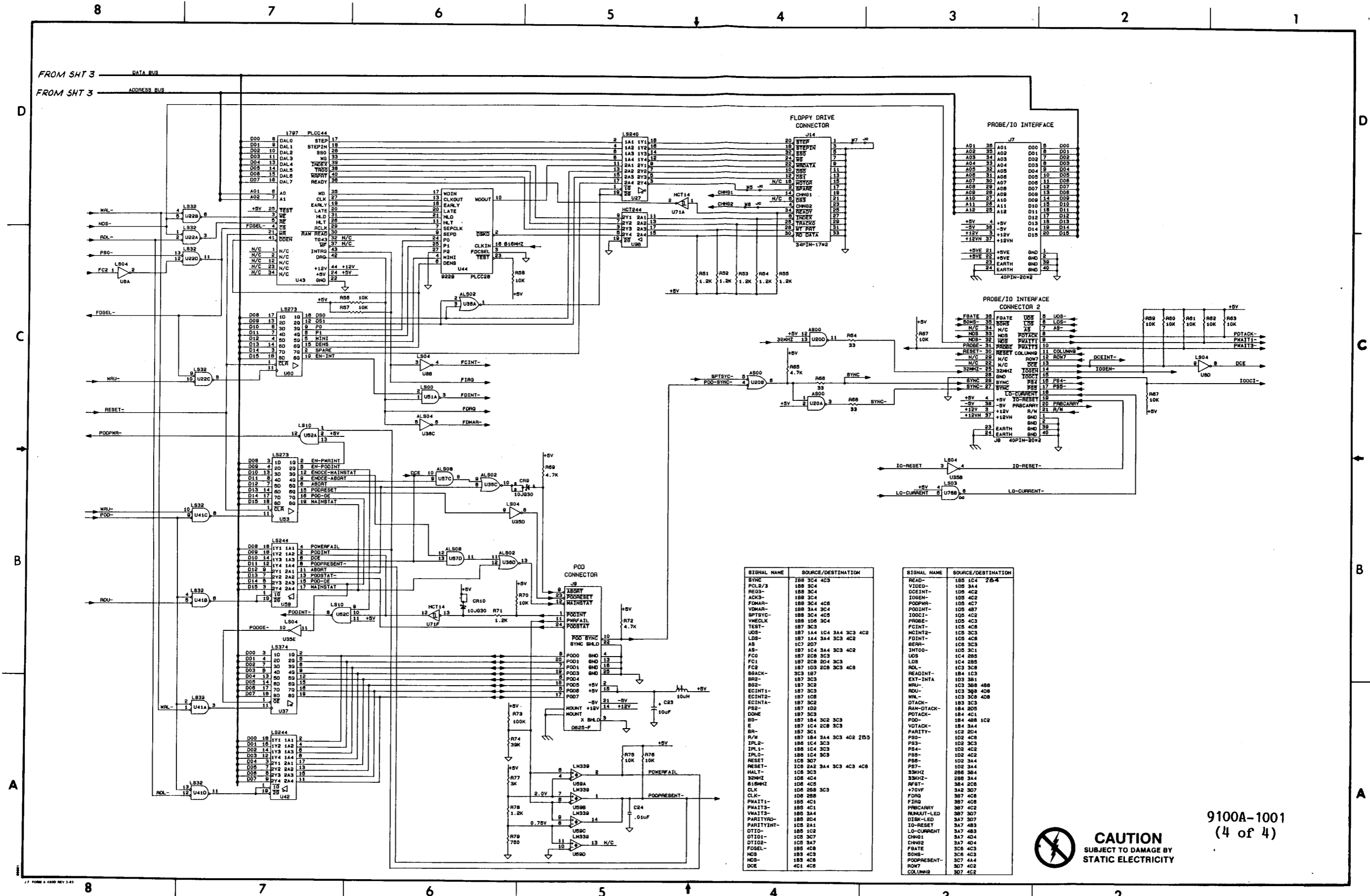
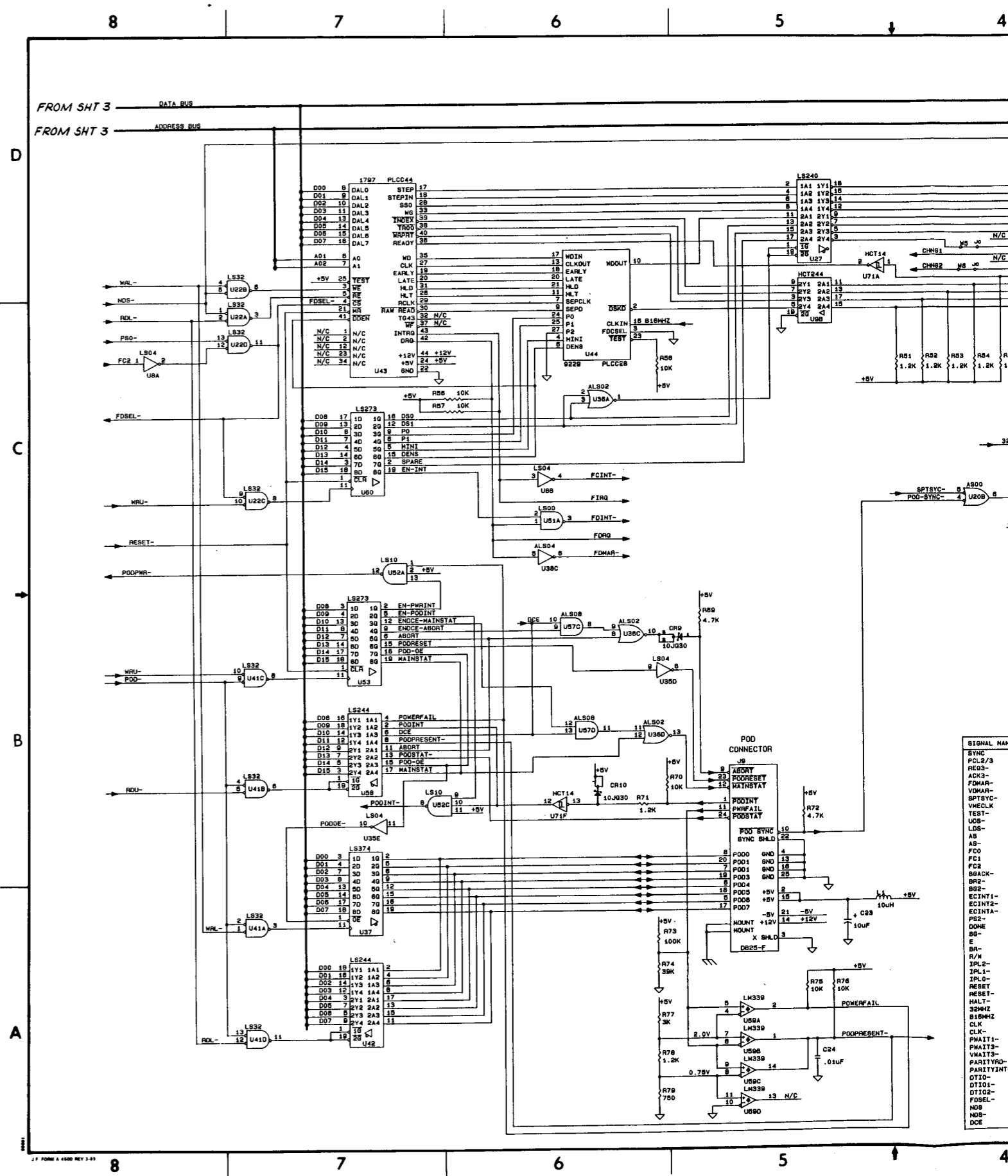

Figure 7-1. A1 Main PCA (cont.)



FROM SHT 3
DATA BUS
ADDRESS BUS

D
C
B
A

SIGNAL NAME	
BYNC	
PCL2/3	
REG3	
ACK3	
FMAR	
VDMAR	
SPTSYN	
VHECK	
TEST	
USB	
LDS	
AS	
AB	
FCO	
FC1	
FC2	
SHACK	
BR2	
BQ2	
ECINT1	
ECINT2	
ECINTA	
PS2	
DSNE	
DS-	
E	
RA-	
R/N	
IPL2-	
IPL1-	
IPLO	
REBET	
HALT-	
32MHz	
CLK	
CLK	
PWAIT1-	
VWAIT3-	
PARTYRD-	
PARTYINT-	
DTIO-	
DTIO1-	
DTIO2-	
FSSEL-	
NBS	
NBS-	
DCE	

NOTES: UNLESS OTHERWISE SPECIFIED:
 1. ALL RESISTORS VALUES ARE IN OHMS, 1/K, OR M
 2. ALL CAPACITOR VALUES ARE IN MICROFARADS.

WARNING: ⚡ INDICATES USAGE OF MOS DEVICE(S)
 WHICH MAY BE DAMAGED BY STATIC DISCHARGE. USE SPECIAL
 HANDLING PER S.O.P. 19.1

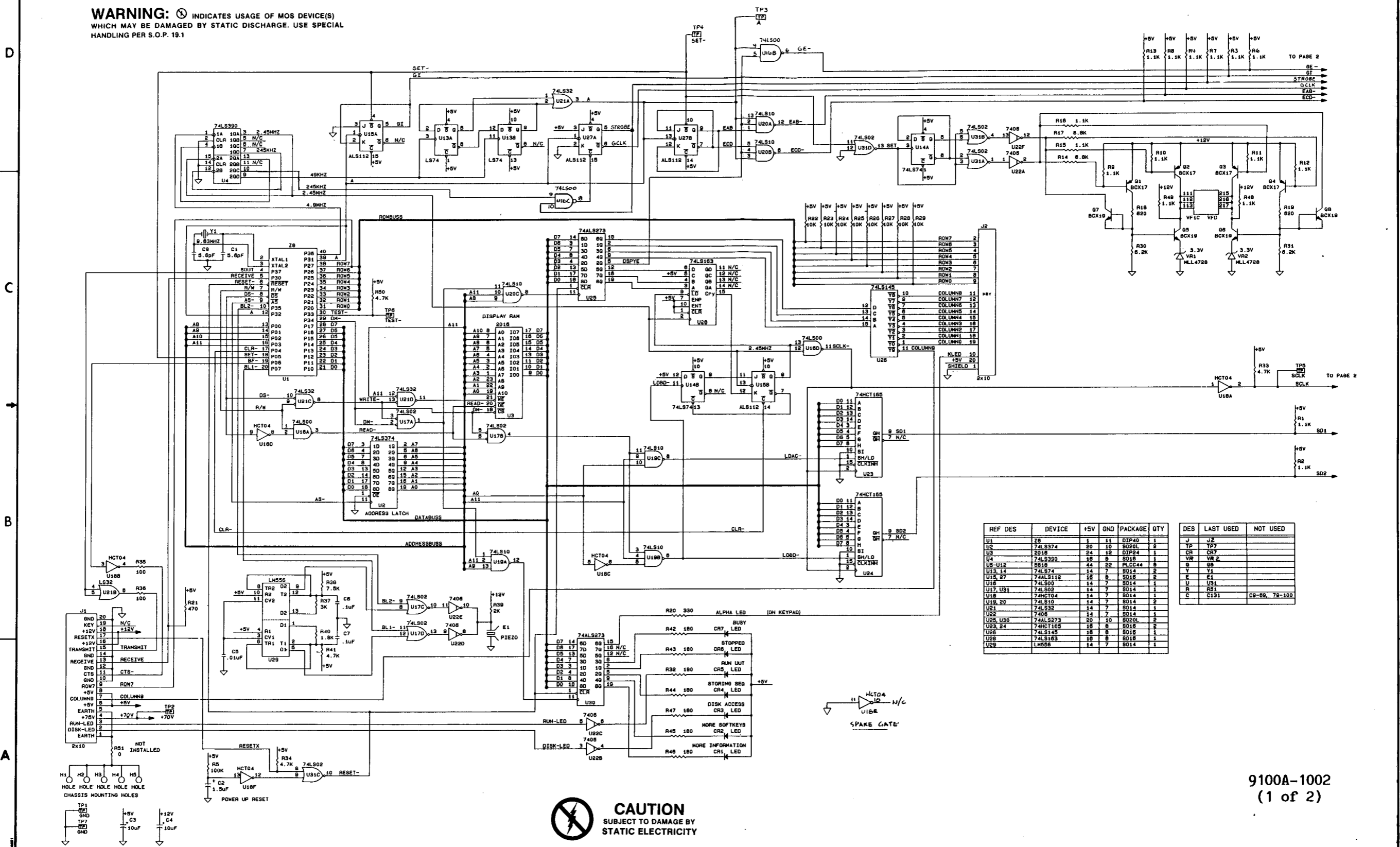

REF DES	DEVICE	+5V	GND	PACKAGE	QTY	DES	LAST USED	NOT USED
U1	74LS273	1	11	DIP40	1	J	J2	
U2	74LS145	20	10	SO16	1	TP	TP7	
U3	74LS90	24	12	DIP24	1	CR	CR7	
U4	74LS90	48	8	SO16	1	VR	VR 2	
U5-U12	74LS00	44	22	PLCC44	8	Q	Q8	
U13, 14	74LS74	14	7	SO14	2	Y	Y1	
U15, 27	74LS112	16	8	SO16	2	E	E1	
U16	74LS00	14	7	SO14	1	U	U31	
U17, U31	74LS02	14	7	SO14	1	R	R51	
U18	74HCT04	14	7	SO14	1	C	C191	CB-89, 78-100
U19, 20	74LS10	14	7	SO14	2			
U21	74LS32	14	7	SO14	1			
U22	7408	14	7	SO14	1			
U23, U30	74LS273	20	10	SO16	2			
U24	74HCT165	16	8	SO16	2			
U25	74LS145	16	8	SO16	1			
U26	74LS145	16	8	SO16	1			
U29	LM555	14	7	SO14	1			

CAUTION
 SUBJECT TO DAMAGE BY
 STATIC ELECTRICITY

9100A-1002
 (1 of 2)

Figure 7-2. A2 Display Interface PCA

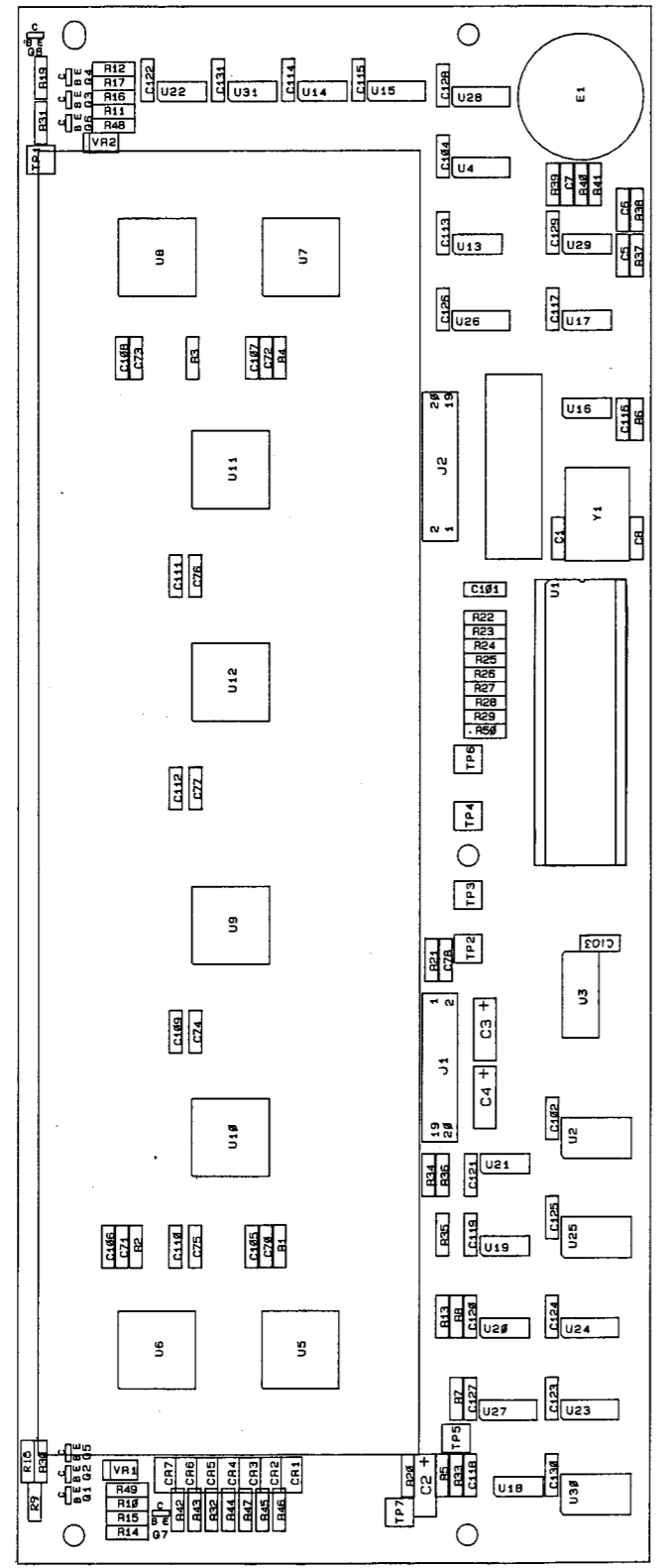

9100A-1602

NOTES: UNLESS OTHERWISE SPECIFIED,
 1. ALL RESISTOR VALUES ARE IN OHMS, 1/KM, M
 2. ALL CAPACITOR VALUES ARE IN MICROFARADS.

WARNING: ⚡ INDICATES USAGE OF MOS DEVICE(S)
 WHICH MAY BE DAMAGED BY STATIC DISCHARGE. USE SPECIAL
 HANDLING PER S.O.P. 19.1

D
 C
 B
 A

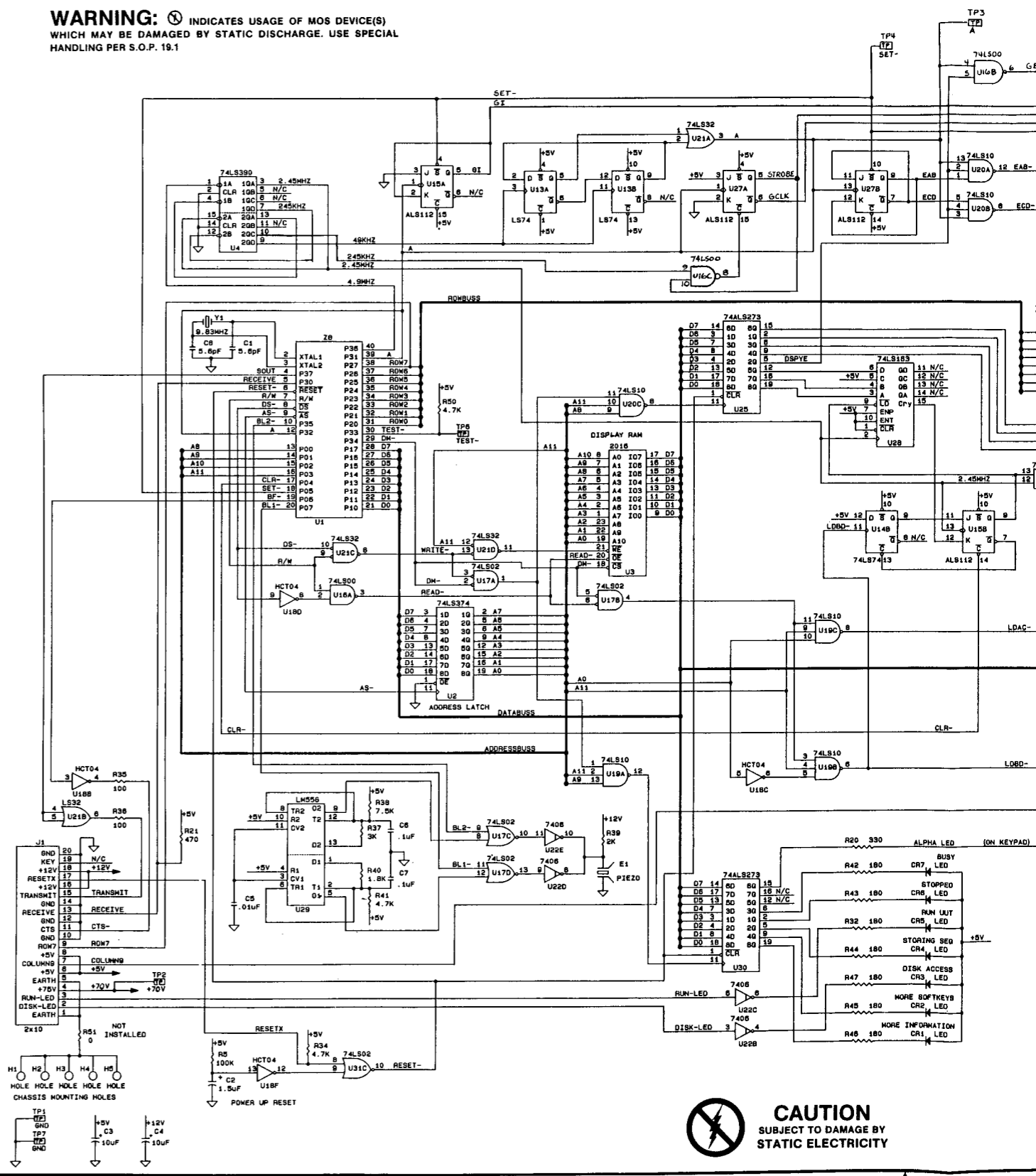

CAUTION
 SUBJECT TO DAMAGE BY
 STATIC ELECTRICITY

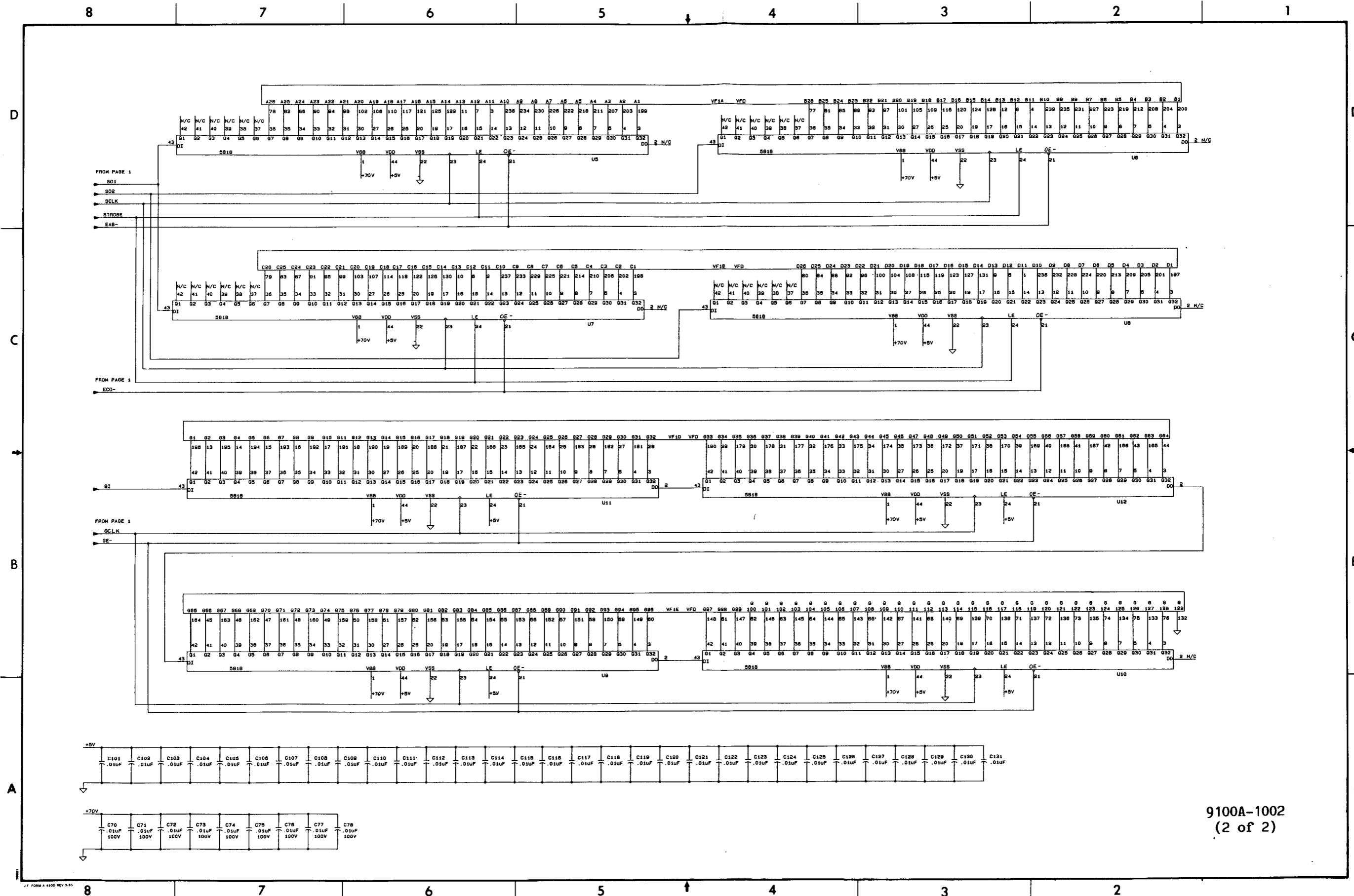

9100A-1002
(2 of 2)

Figure 7-2. A2 Display Interface PCA (cont.)

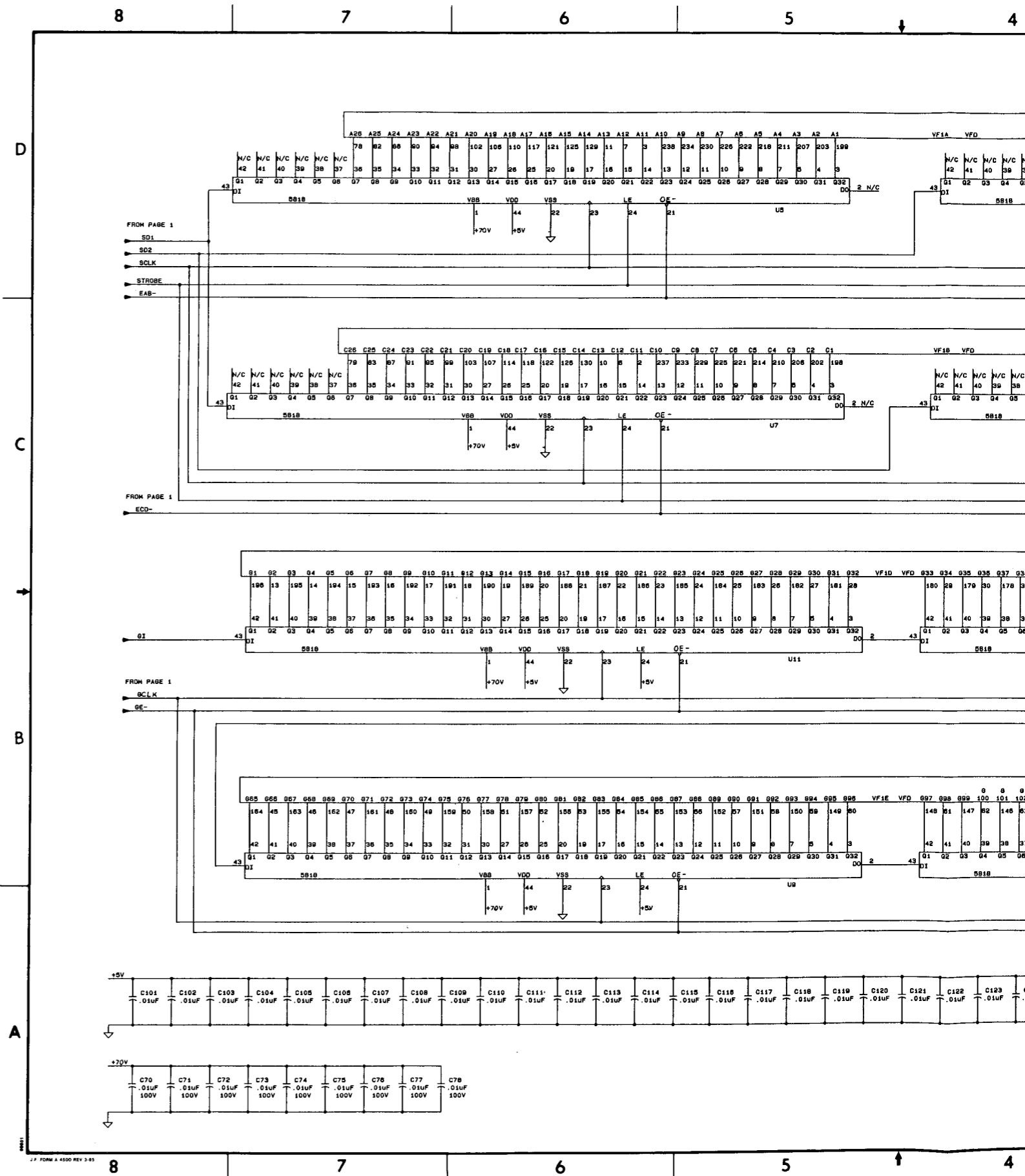

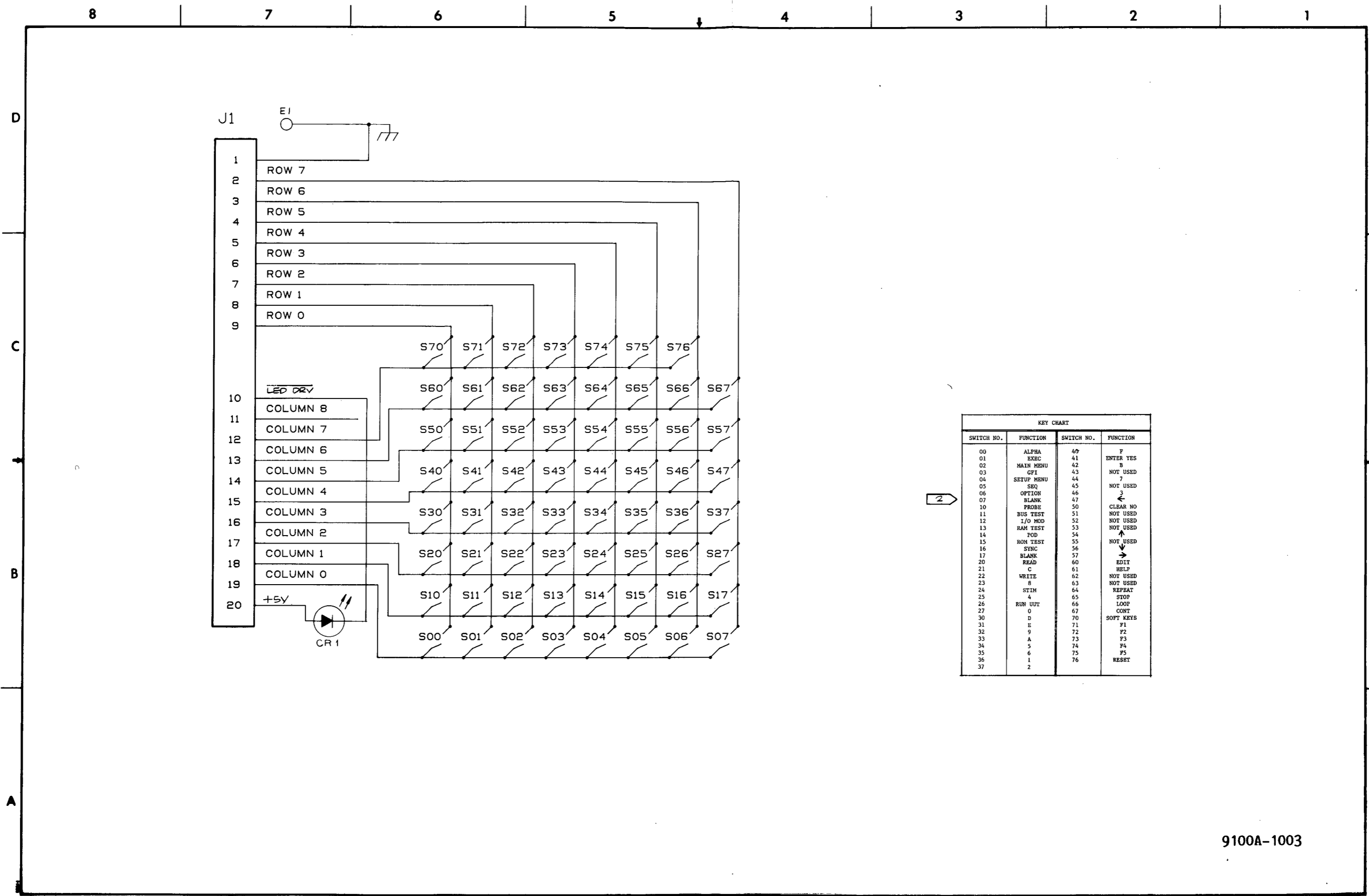

9100A-1003

Figure 7-3. A3 Keypad PCA

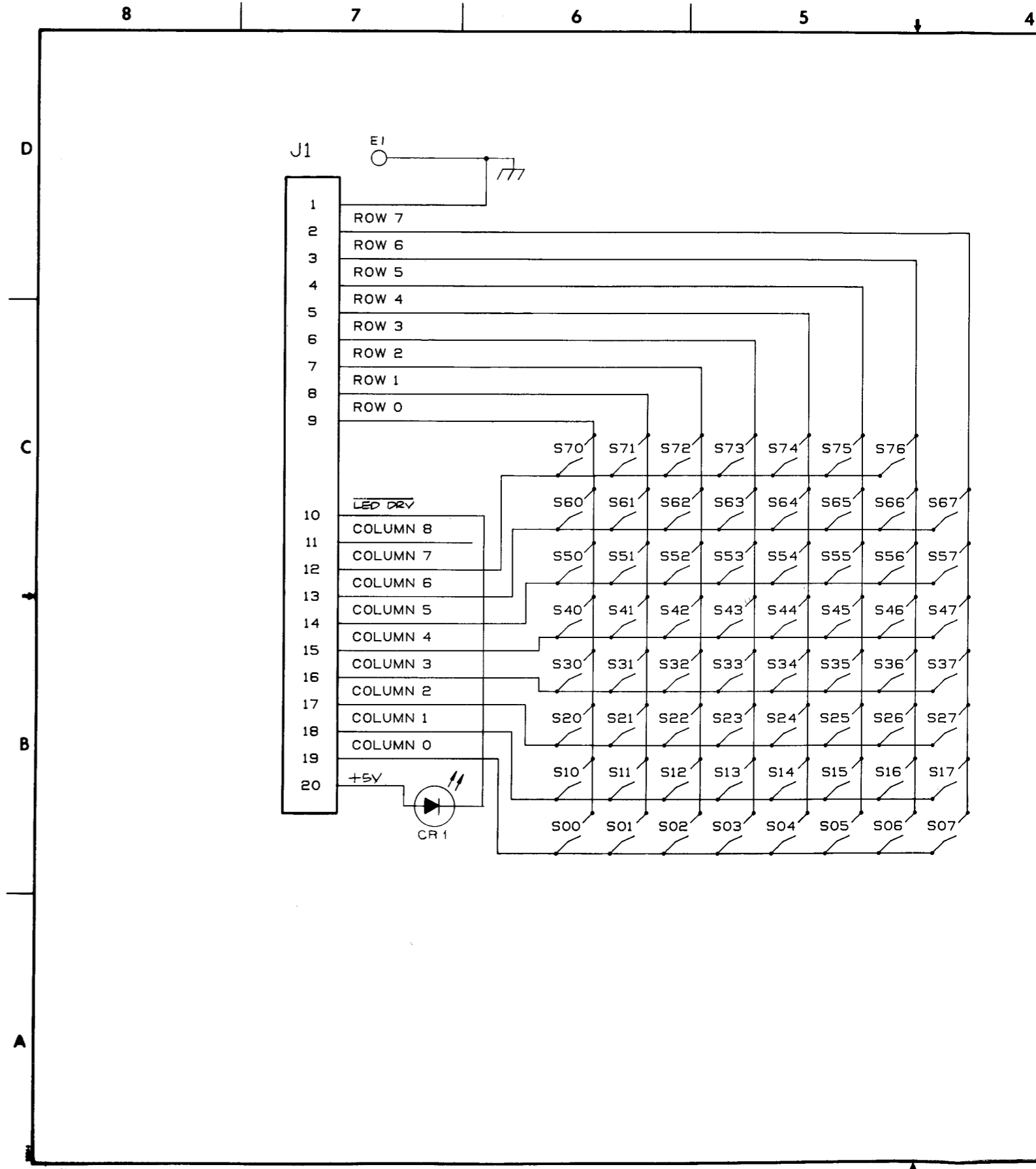

NOTES: UNLESS OTHERWISE SPECIFIED.

1. ALL RESISTOR VALUES ARE IN OHMS, $\frac{1}{8}W$, 5%.
2. ALL CAPACITOR VALUES ARE IN MICROFARADS.

WARNING: INDICATES USAGE OF MOS DEVICE(S) WHICH MAY BE DAMAGED BY STATIC DISCHARGE. USE SPECIAL HANDLING PER S.O.P. 19.1

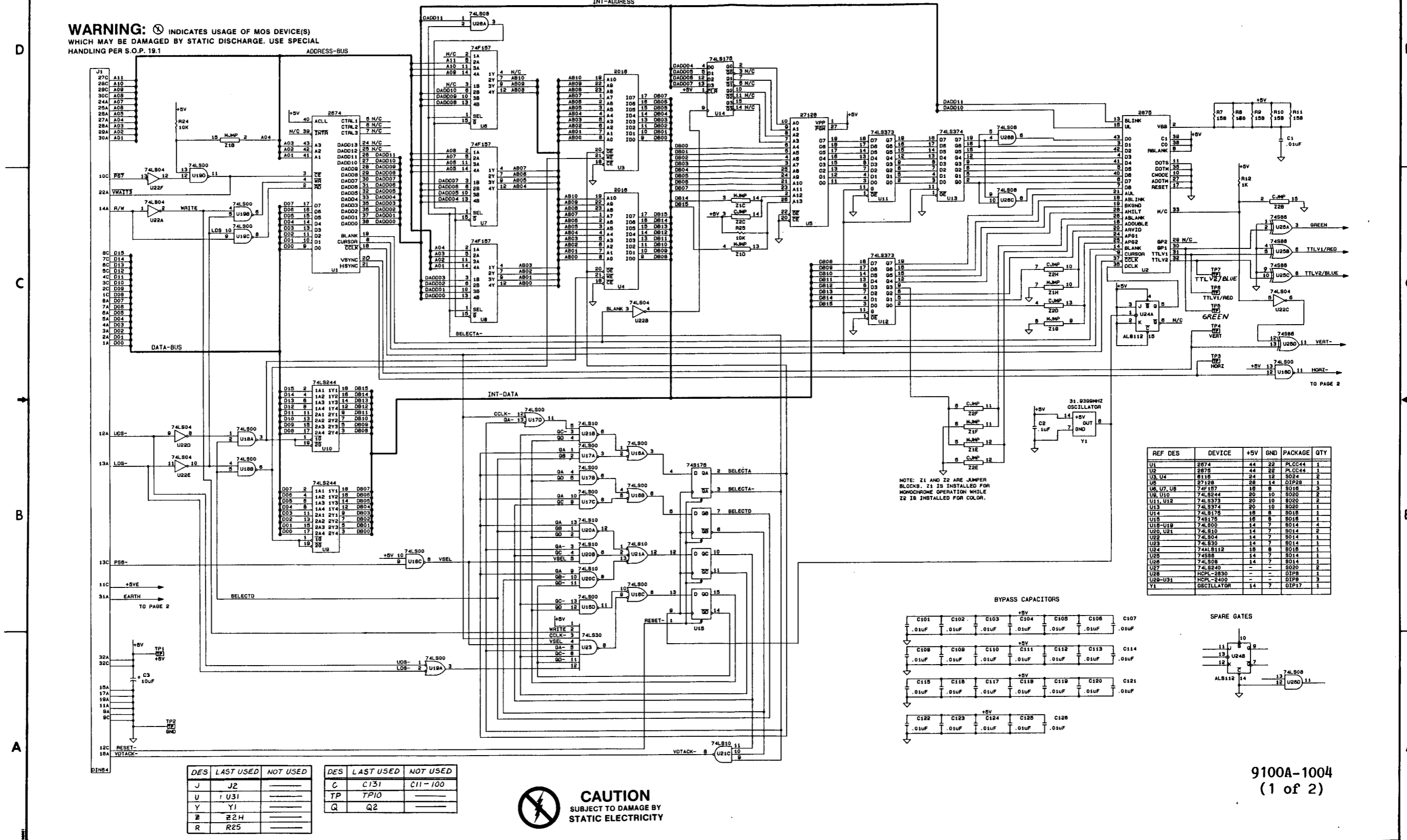

REF DES	DEVICE	+5V	GND	PACKAGE	QTY
U1	2874	44	22	PLCC44	1
U2	2875	44	22	PLCC44	1
U3, U4	8116	24	12	SO24	2
U5	2715B	28	14	DIP28	1
U6, U7, U8	74F157	18	8	SO16	3
U9, U10	74LS244	20	10	SO20	2
U11, U12	74LS373	20	10	SO20	2
U13	74LS374	20	10	SO20	1
U14	74LS178	18	8	SO16	1
U15	74LS175	18	8	SO16	1
U16-U19	74LS00	14	7	SO14	4
U20, U21	74LS10	14	7	SO14	2
U22	74LS04	14	7	SO14	1
U23	74LS30	14	7	SO14	1
U24	74ALS112	18	8	SO16	1
U25	74S88	14	7	SO14	1
U26	74LS08	14	7	SO14	1
U27	74LS240	-	-	SO30	2
U28	HCPL-2830	-	-	DIP8	1
U29-U31	HCPL-2400	-	-	DIP8	3
Y1	OSCILLATOR	14	7	DIP17	1

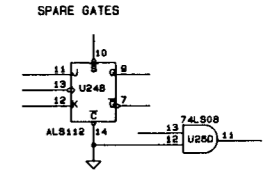
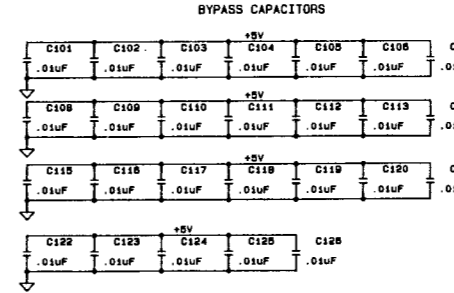

DES	LAST USED	NOT USED	DES	LAST USED	NOT USED
J	J2	---	C	C131	C11-100
U	U31	---	TP	TP10	---
Y	Y1	---	Q	Q2	---
Z	Z2H	---			
R	R25	---			

CAUTION
SUBJECT TO DAMAGE BY
STATIC ELECTRICITY

9100A-1004
(1 of 2)

Figure 7-4. A4 Video Controller PCA

NOTES: UNLESS OTHERWISE SPECIFIED.

- 1. ALL RESISTOR VALUES ARE IN OHMS, 1/8W, 5%.
- 2. ALL CAPACITOR VALUES ARE IN MICROFARADS.

WARNING: ⚡ INDICATES USAGE OF MOS DEVICE(S) WHICH MAY BE DAMAGED BY STATIC DISCHARGE. USE SPECIAL HANDLING PER S.O.P. 19.1

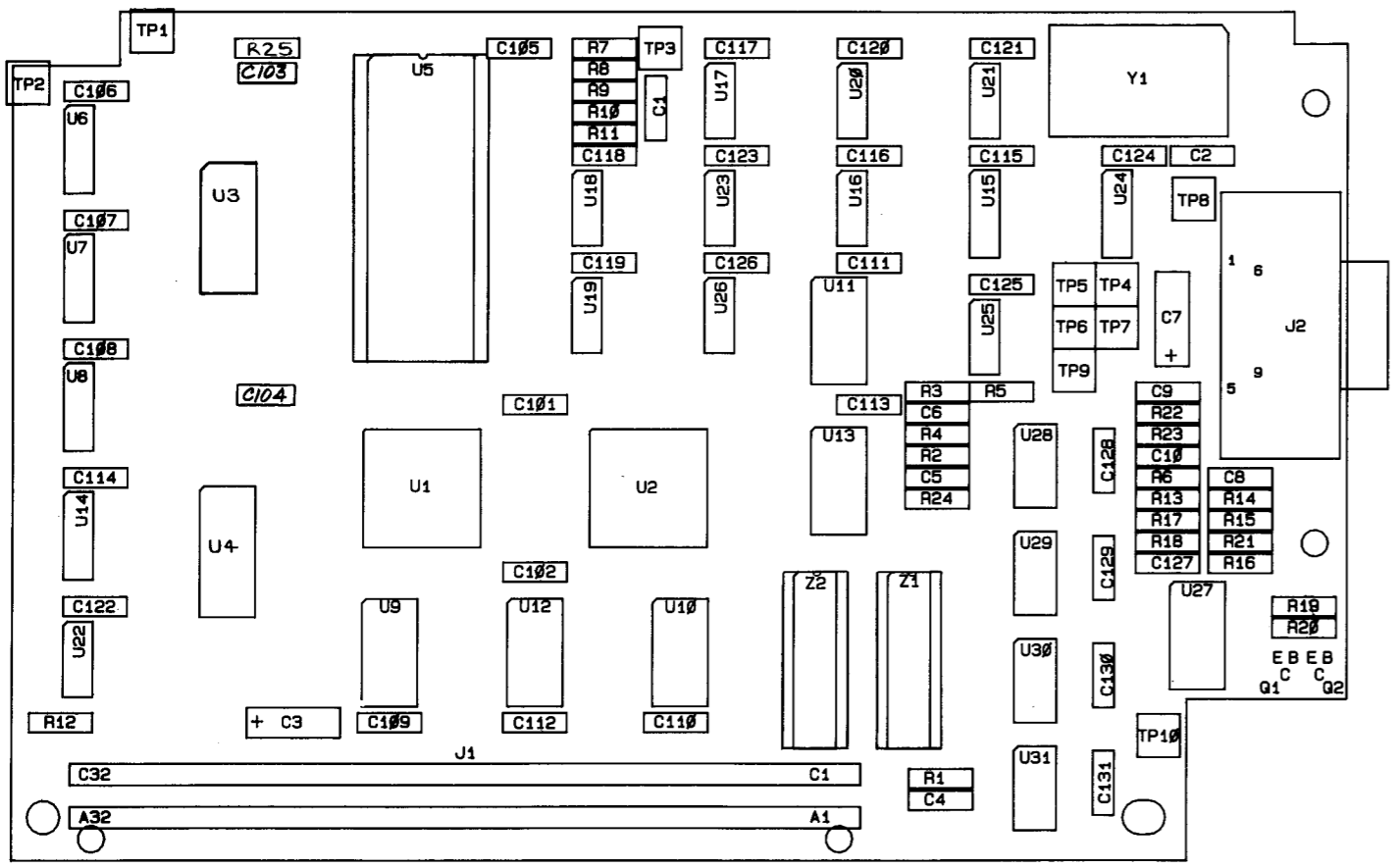

9100A-1604

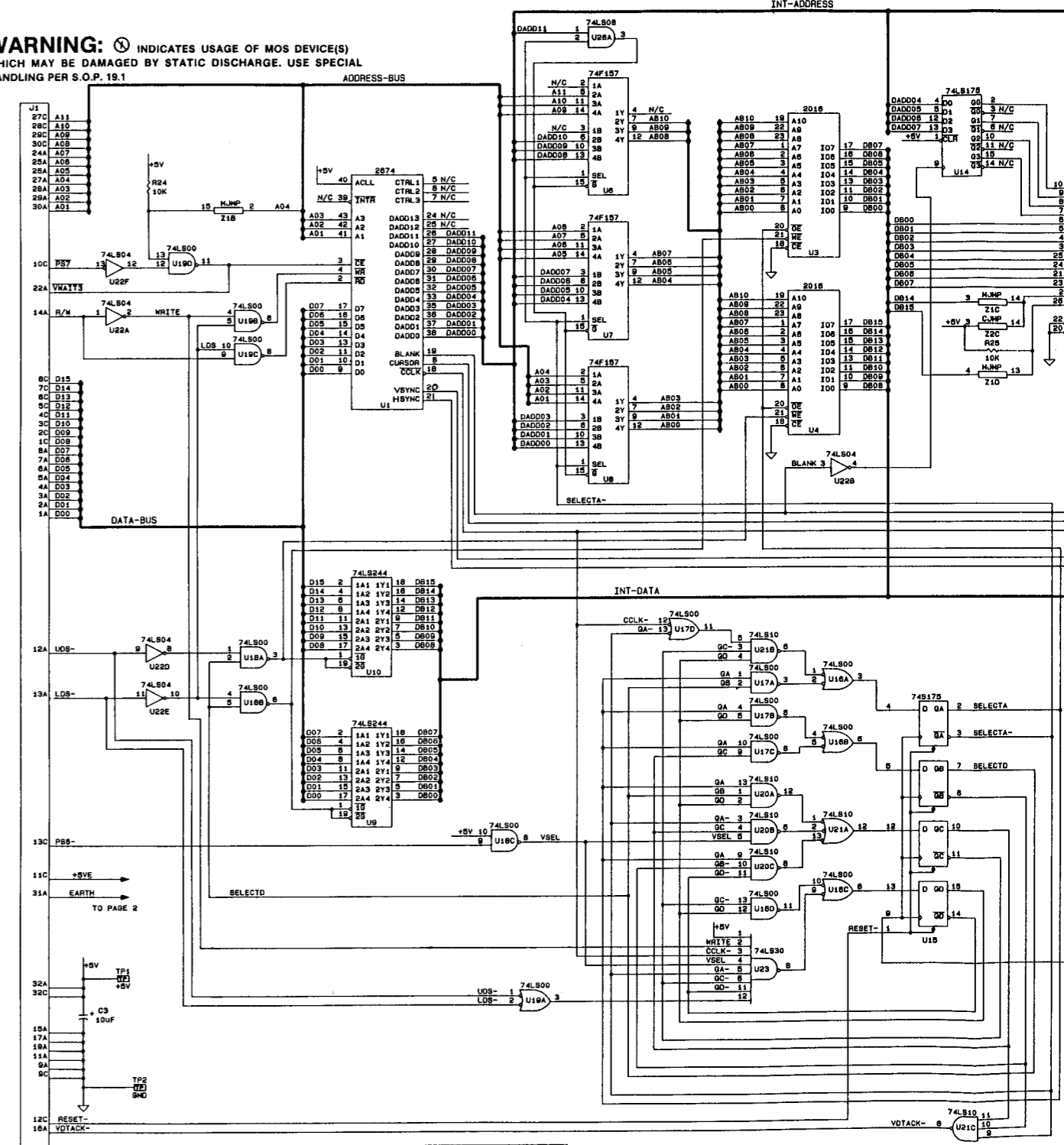

DES	LAST USED	NOT USED
J	J2	---
U	U31	---
Y	Y1	---
Z	Z2H	---
R	R25	---

DES	LAST USED	NOT USED
C	C131	C11-100
TP	TP10	---
Q	Q2	---



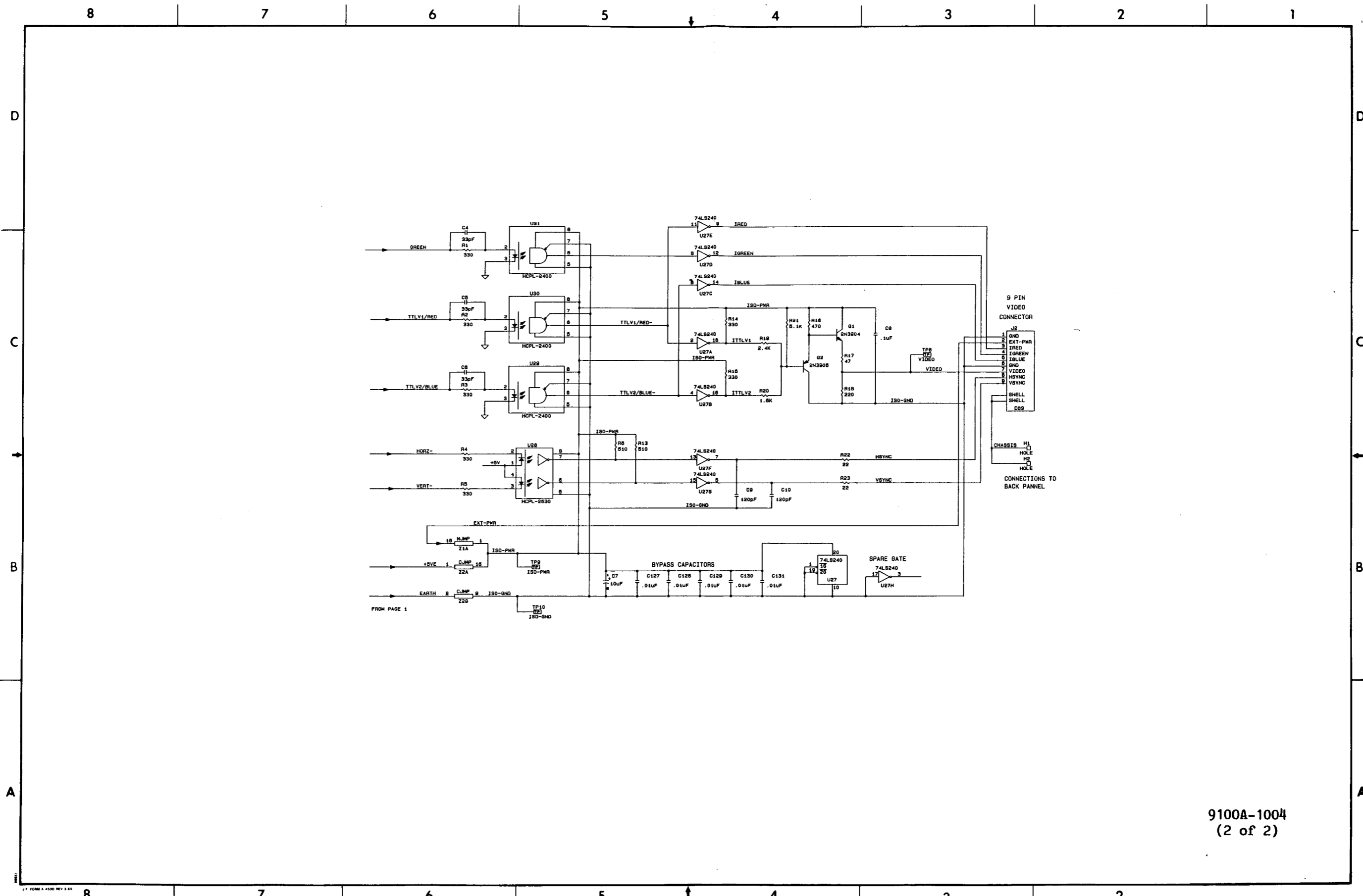

9100A-1004
(2 of 2)

Figure 7-4. A4 Video Controller PCA (cont.)

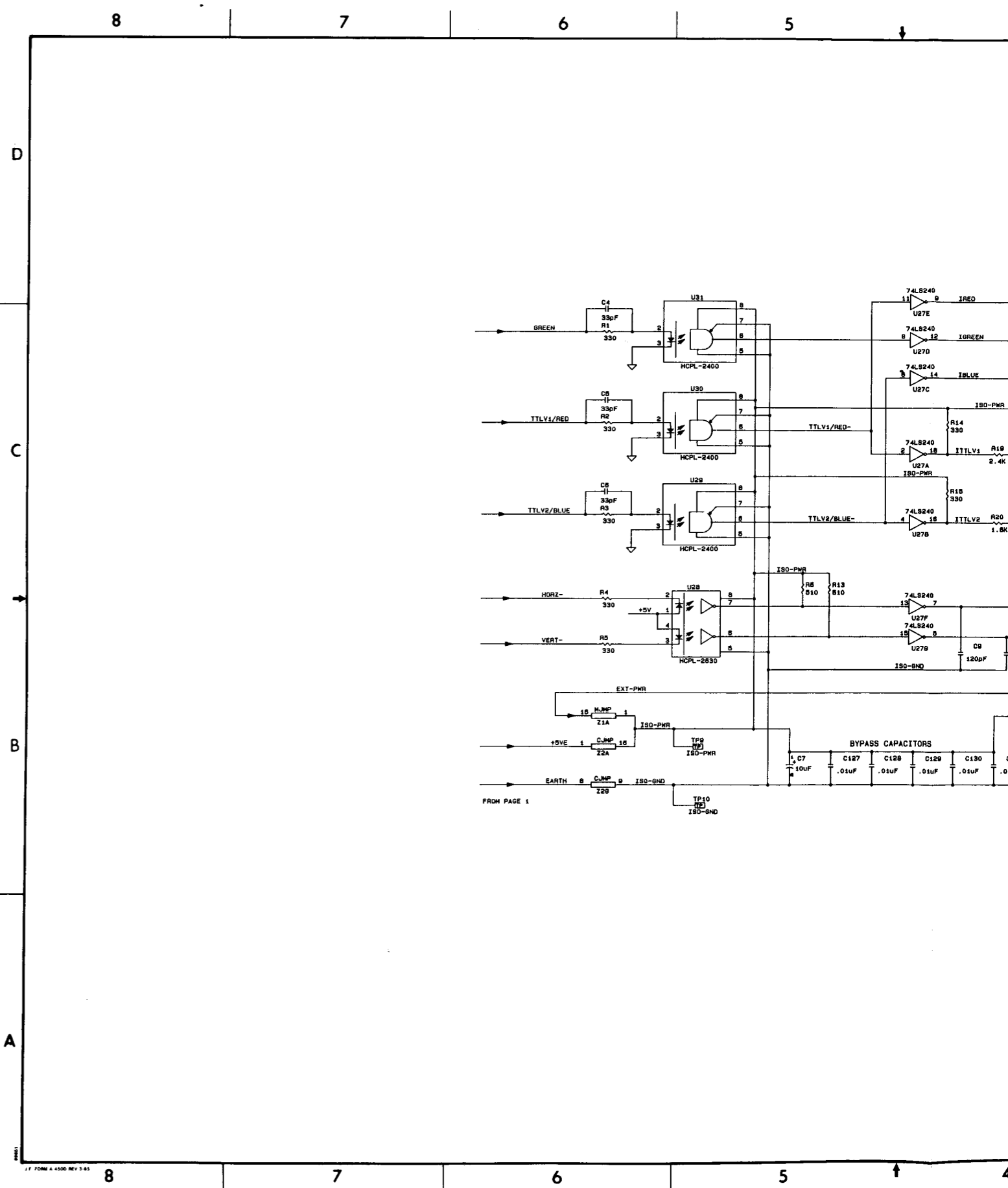

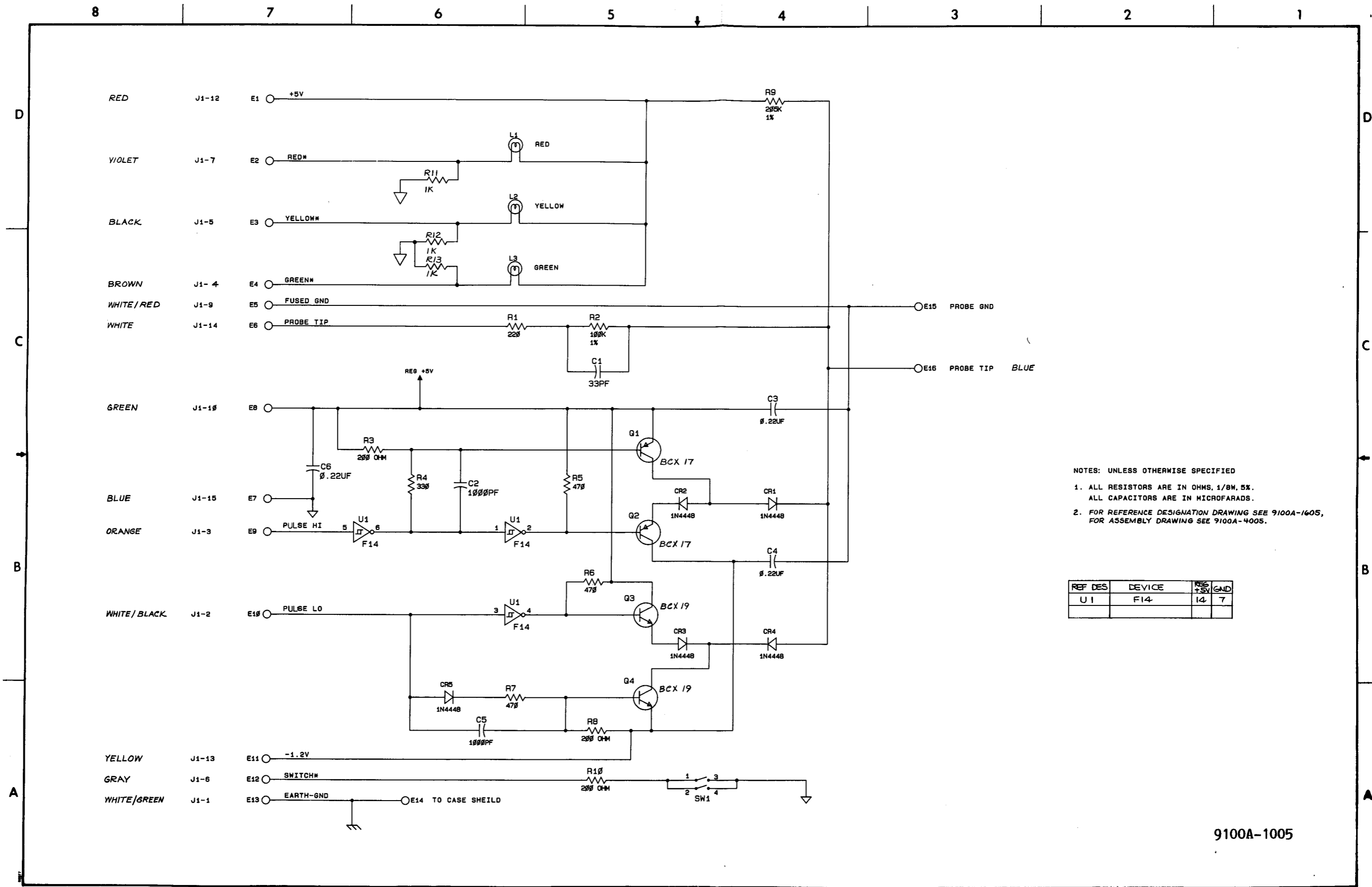

NOTES: UNLESS OTHERWISE SPECIFIED
 1. ALL RESISTORS ARE IN OHMS, 1/8W, 5%.
 ALL CAPACITORS ARE IN MICROFARADS.
 2. FOR REFERENCE DESIGNATION DRAWING SEE 9100A-1605,
 FOR ASSEMBLY DRAWING SEE 9100A-4005.

REF DES	DEVICE	RES	GND
U 1	F14	14	7

9100A-1005

Figure 7-5. A5 Probe PCA

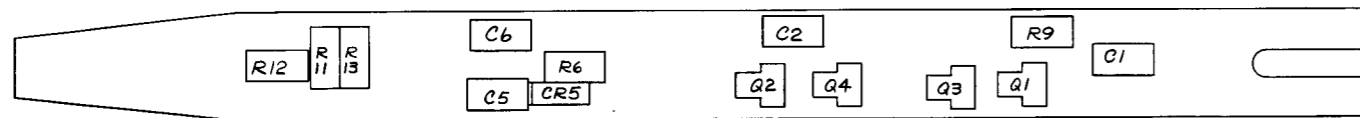

CKT 1

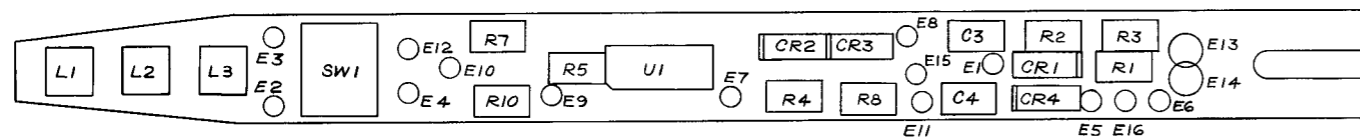

CKT 2

9100A-1605

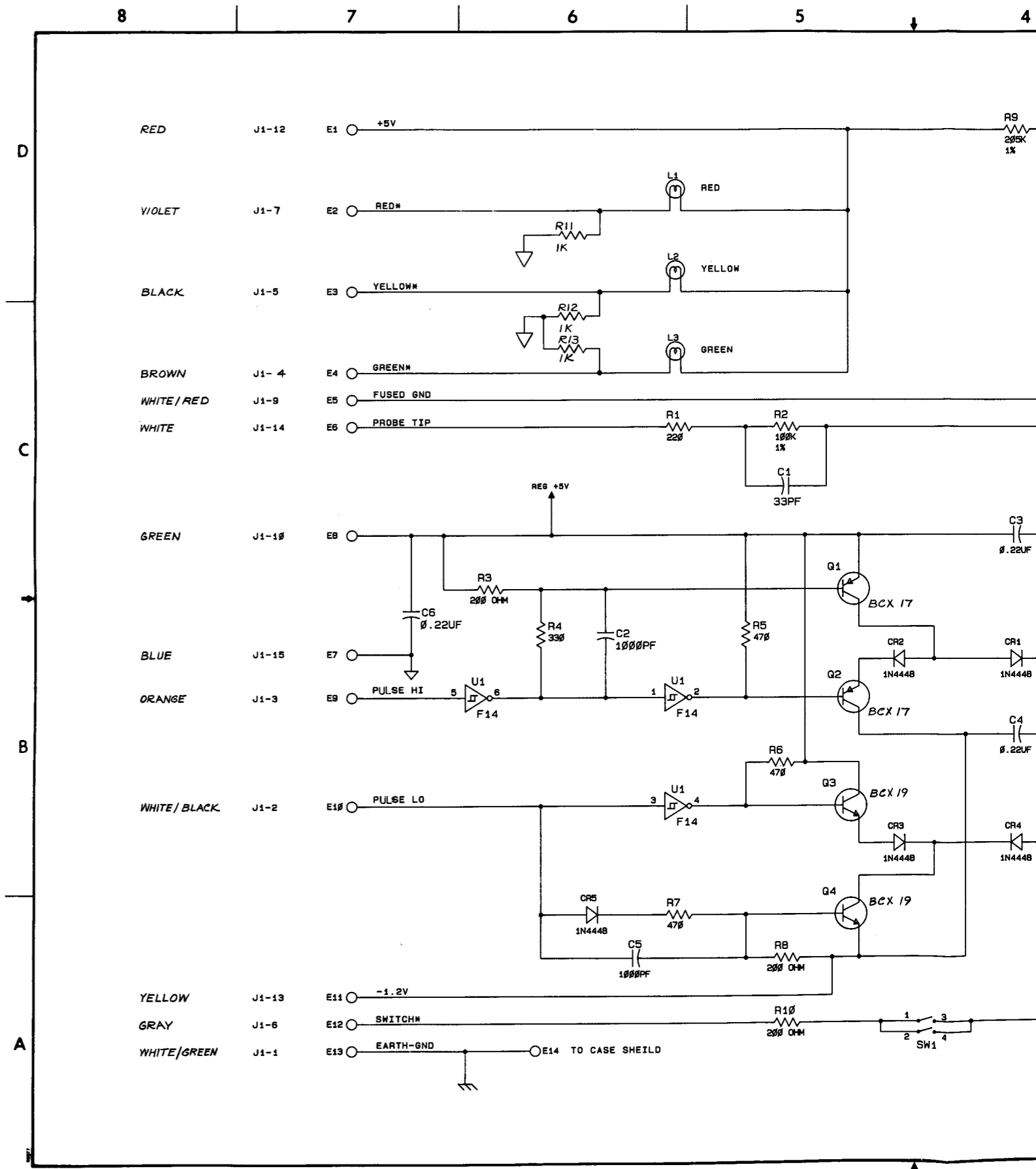

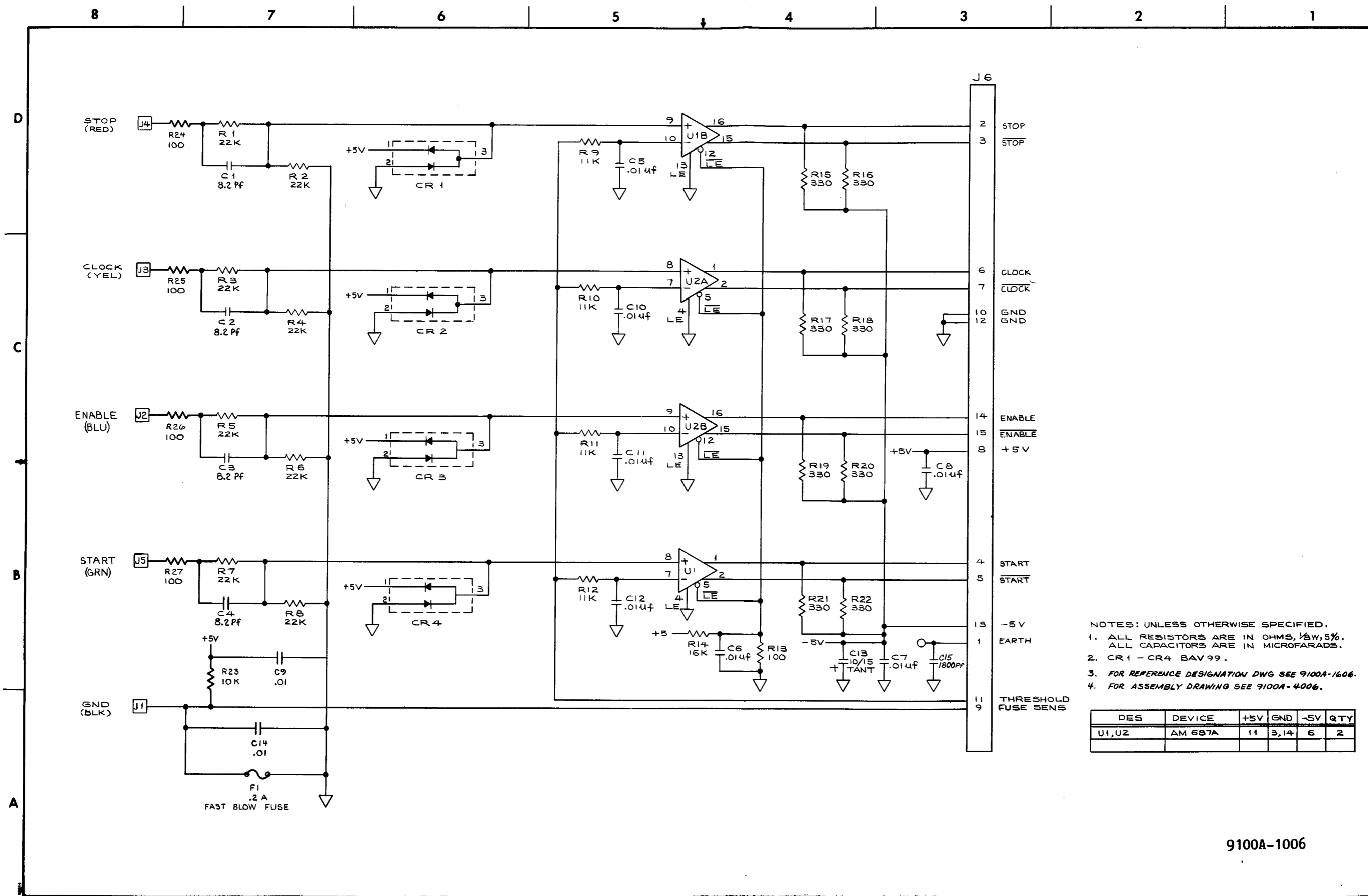

- NOTES: UNLESS OTHERWISE SPECIFIED.
1. ALL RESISTORS ARE IN OHMS, 1/8W, 5%.
 2. ALL CAPACITORS ARE IN MICROFARADS.
 3. CR 1 - CR 4 BAV 99.
 4. FOR REFERENCE DESIGNATION DWG SEE 9100A-1606.
 5. FOR ASSEMBLY DRAWING SEE 9100A-4006.

DES	DEVICE	+5V	GND	-5V	QTY
U1, U2	AM 687A	11	3, 14	6	2

9100A-1006

Figure 7-6. A6 Clock Module PCA

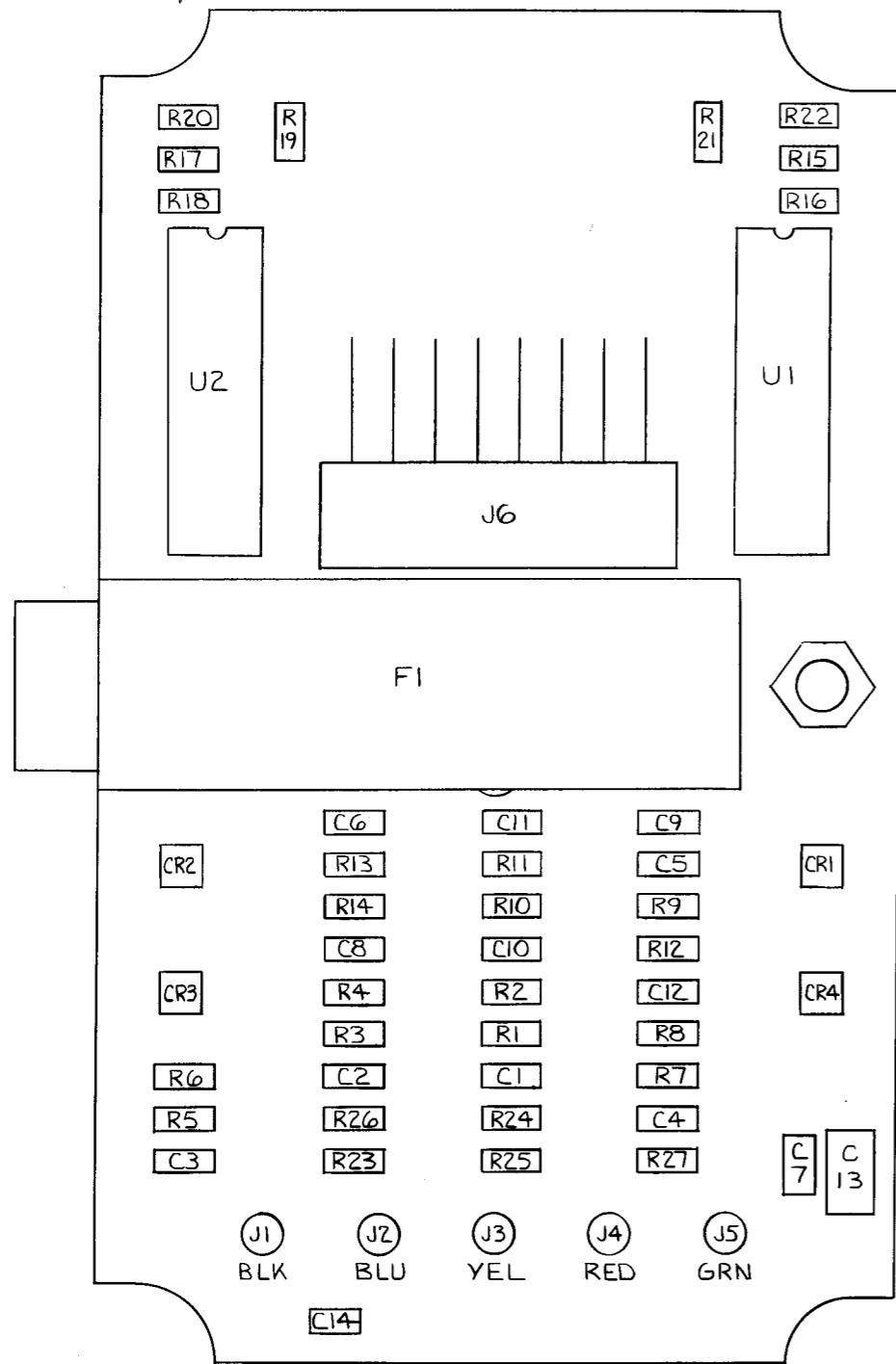

9100A-1606

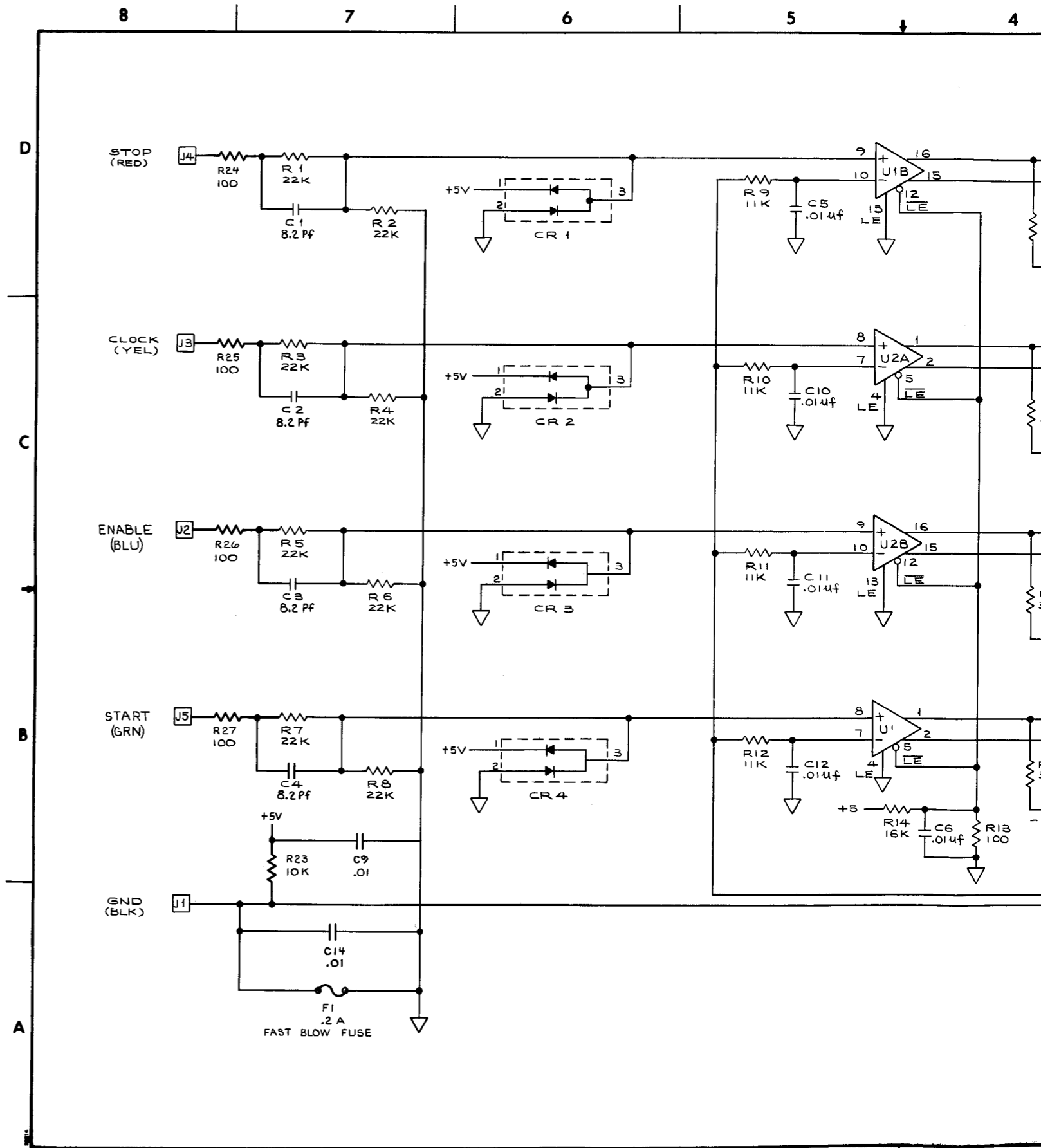

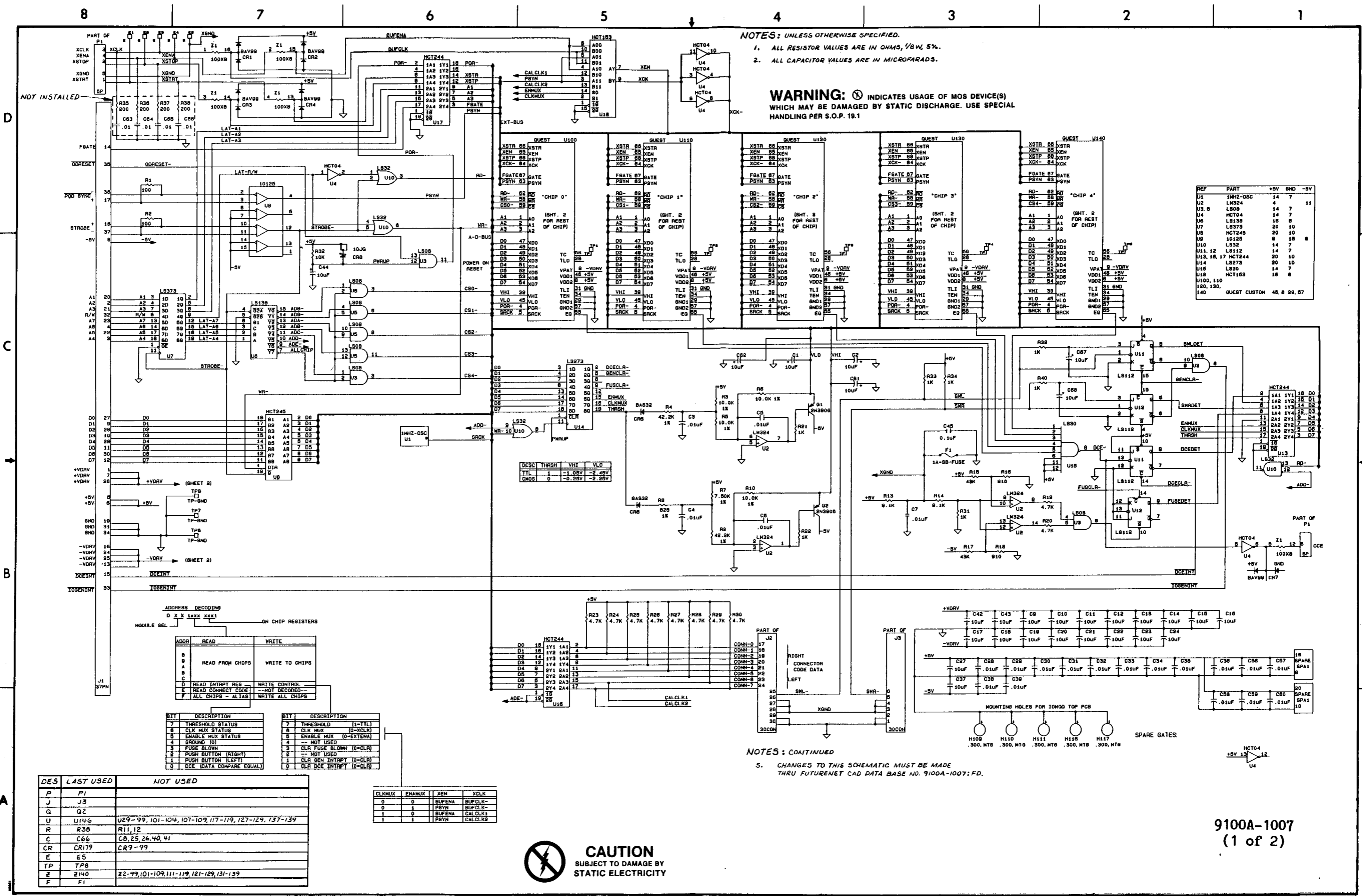
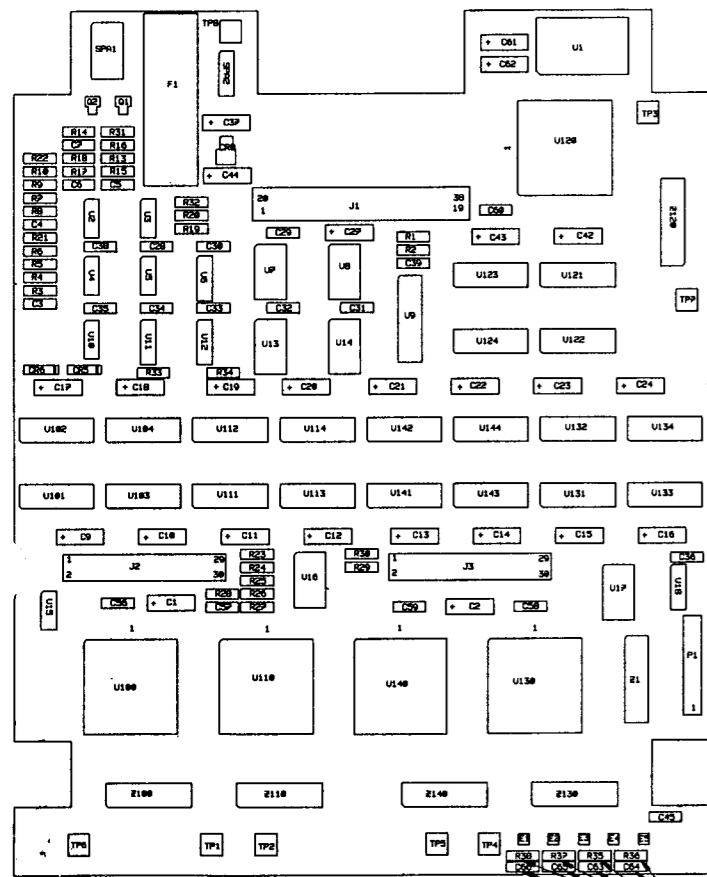
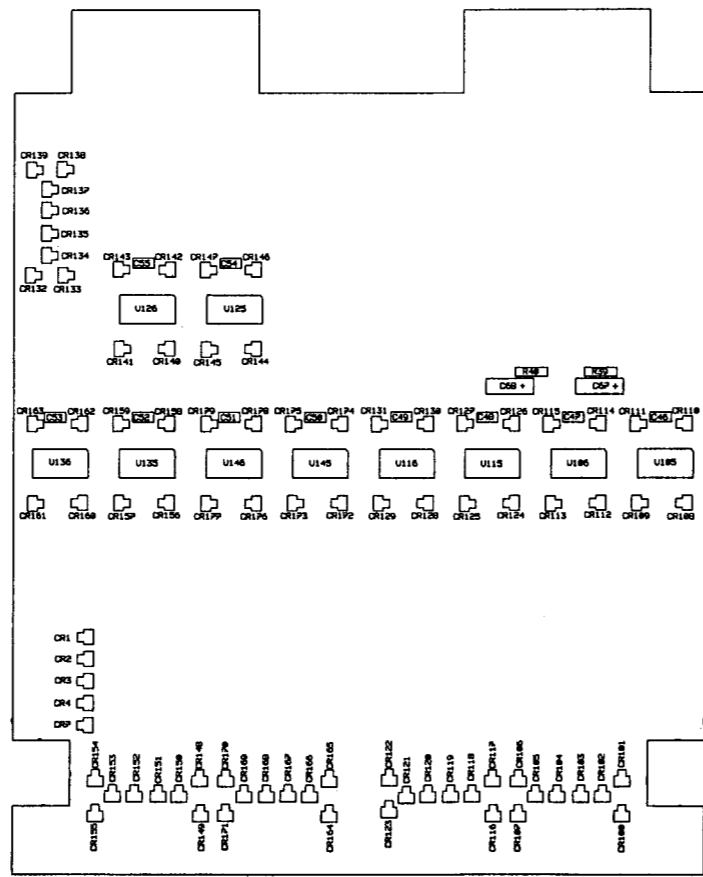

Figure 7-7. A7 I/O Module (Main) PCA



CKT 8



CKT 1

9100A-1607

NOT INSTALLED

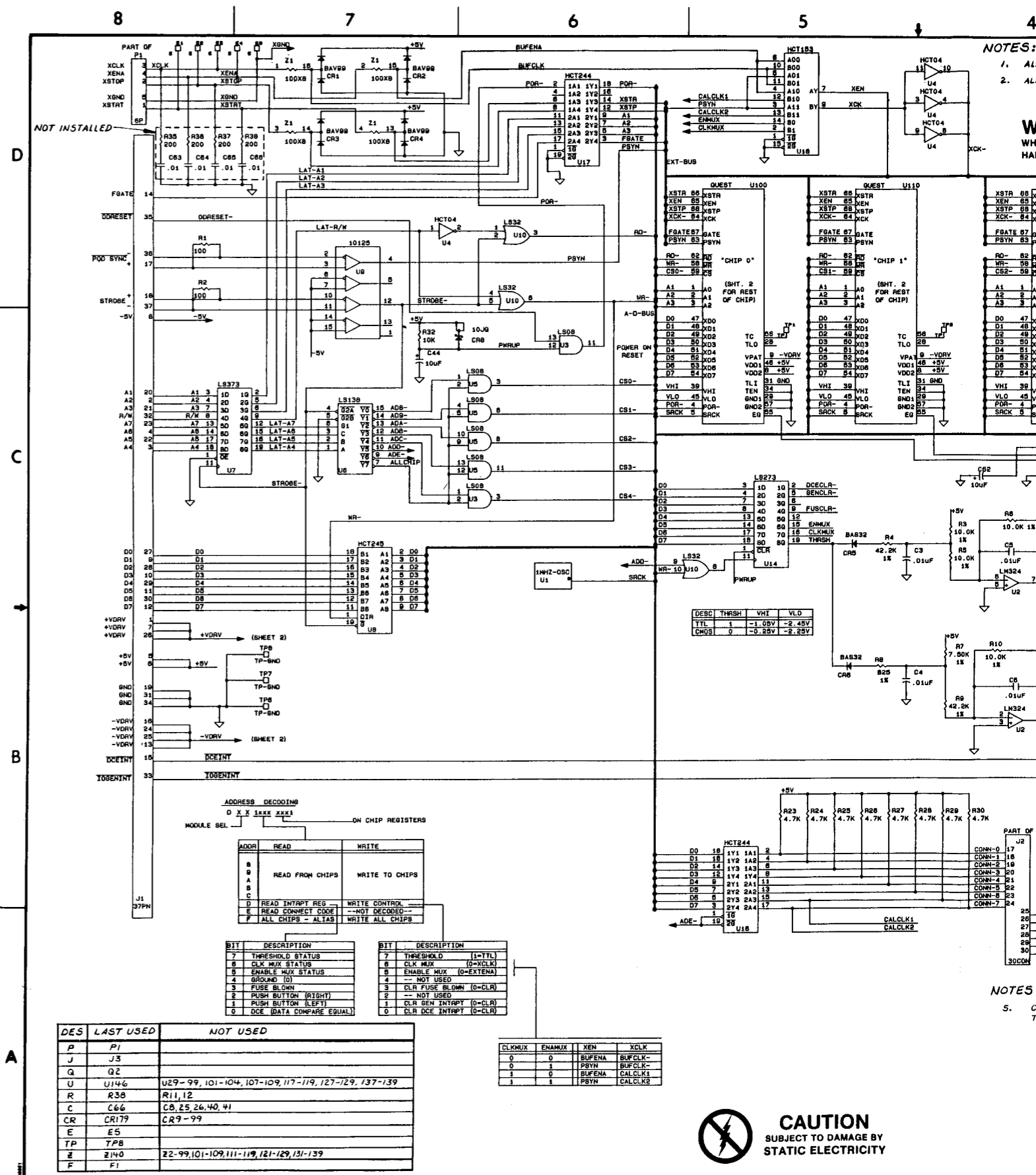

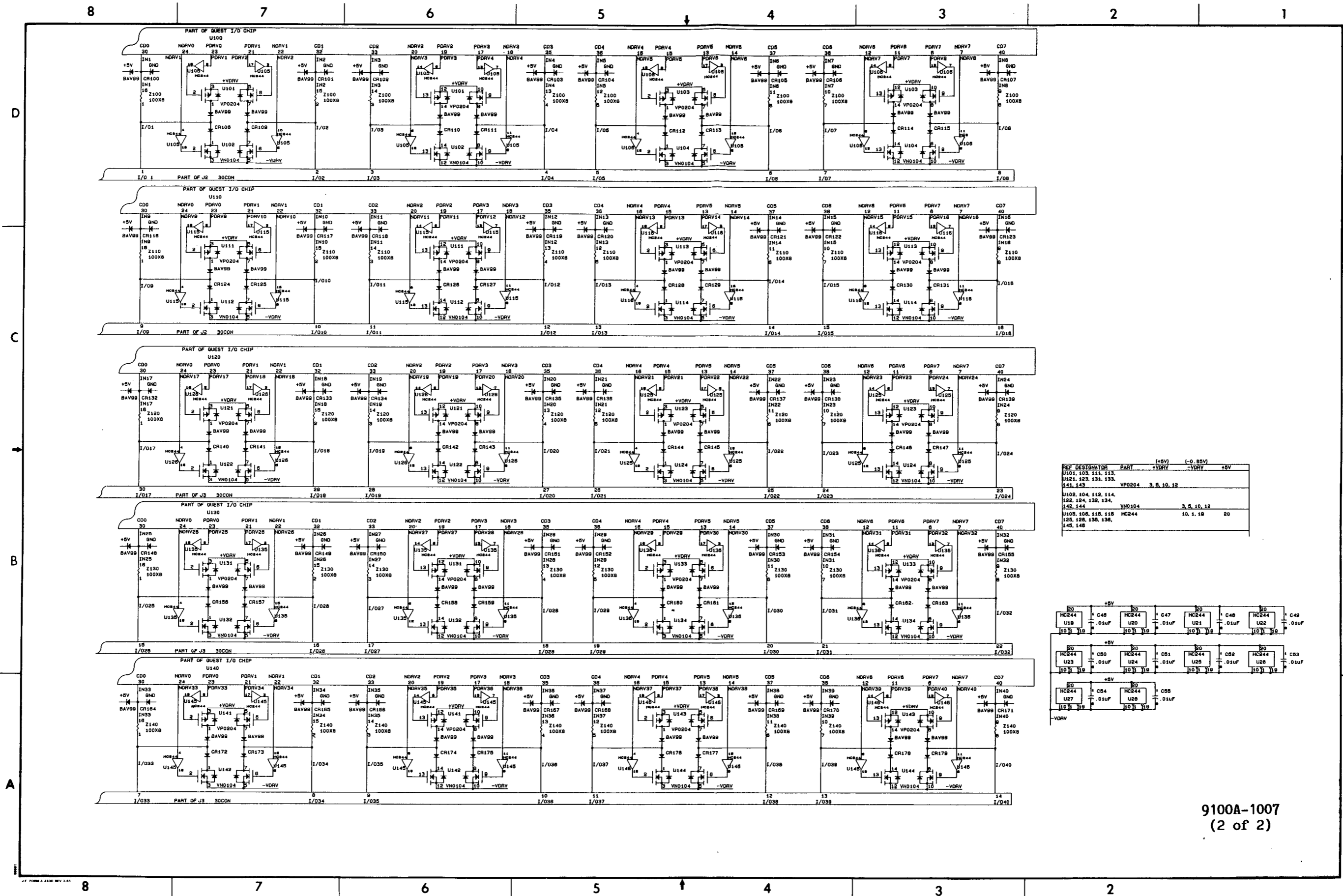

9100A-1007
(2 of 2)

Figure 7-7. A7 I/O Module (Main) PCA (cont.)

D
C
B
A

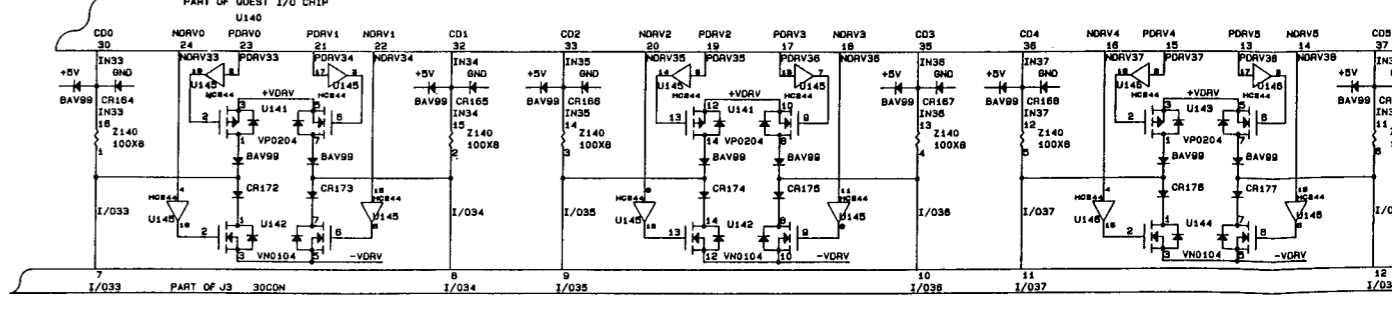
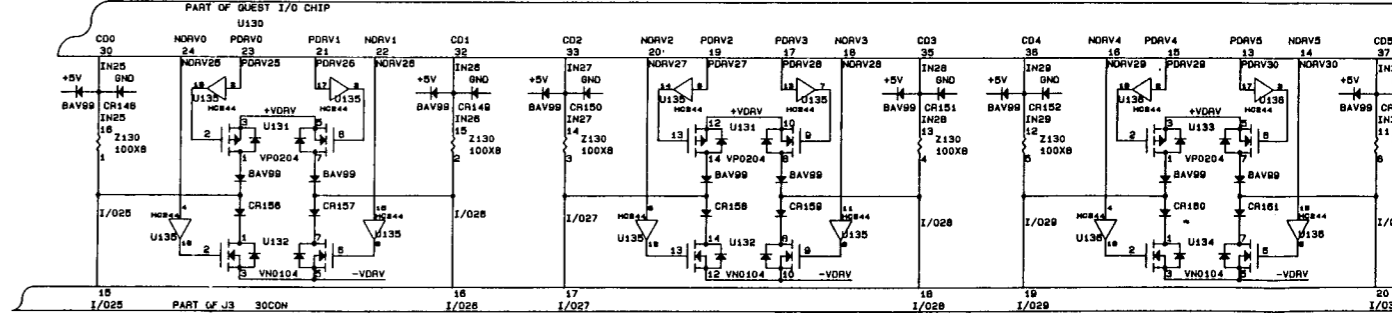
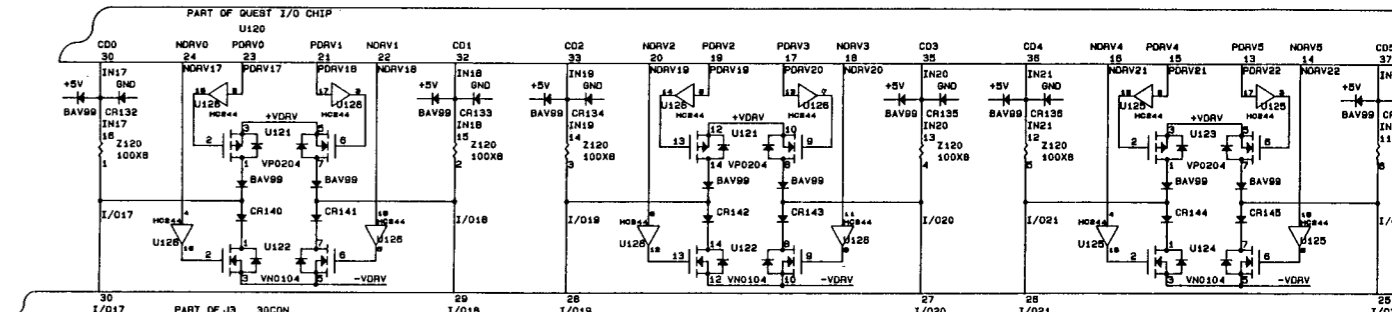
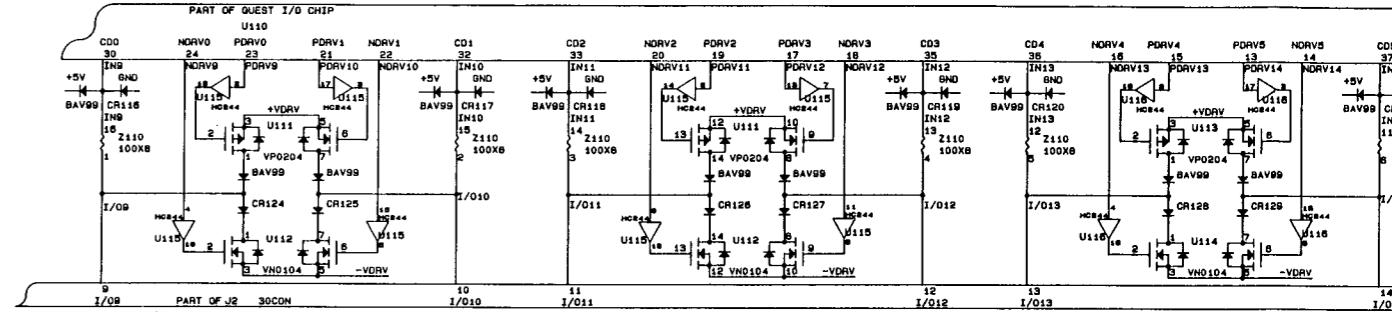
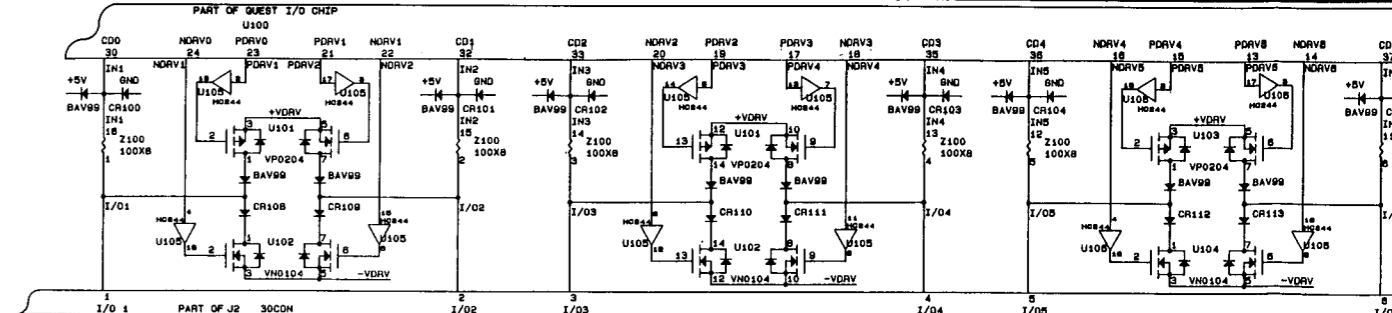

77 FORM 4-4800 REV 3-85

8 7 6 5 4 3 2 1

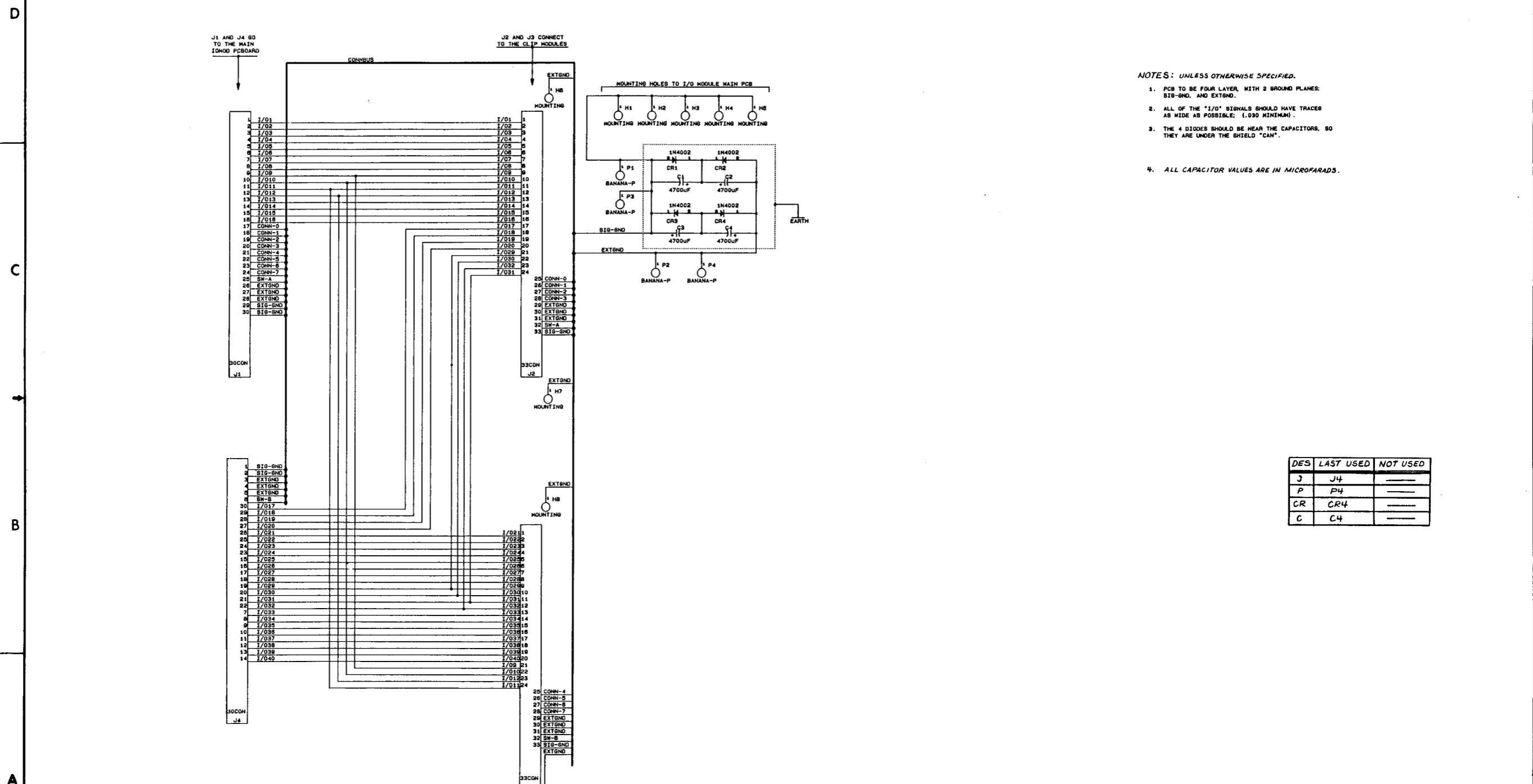

- NOTES: UNLESS OTHERWISE SPECIFIED.
1. PCB TO BE FOUR LAYER, WITH 2 GROUND PLANES: SIG-GND, AND EXTEND.
 2. ALL OF THE "I/O" SIGNALS SHOULD HAVE TRACES AS WIDE AS POSSIBLE; (1.030 MINIMUM).
 3. THE 4 DIODES SHOULD BE NEAR THE CAPACITORS, SO THEY ARE UNDER THE SHIELD "CAN".
 4. ALL CAPACITOR VALUES ARE IN MICROFARADS.

DES	LAST USED	NOT USED
J	J4	---
P	P4	---
CR	CR4	---
C	C4	---

9100A-1008

J.F. FORM 44500 Rev. 2-82

Figure 7-8. A8 I/O Module (Top) PCA

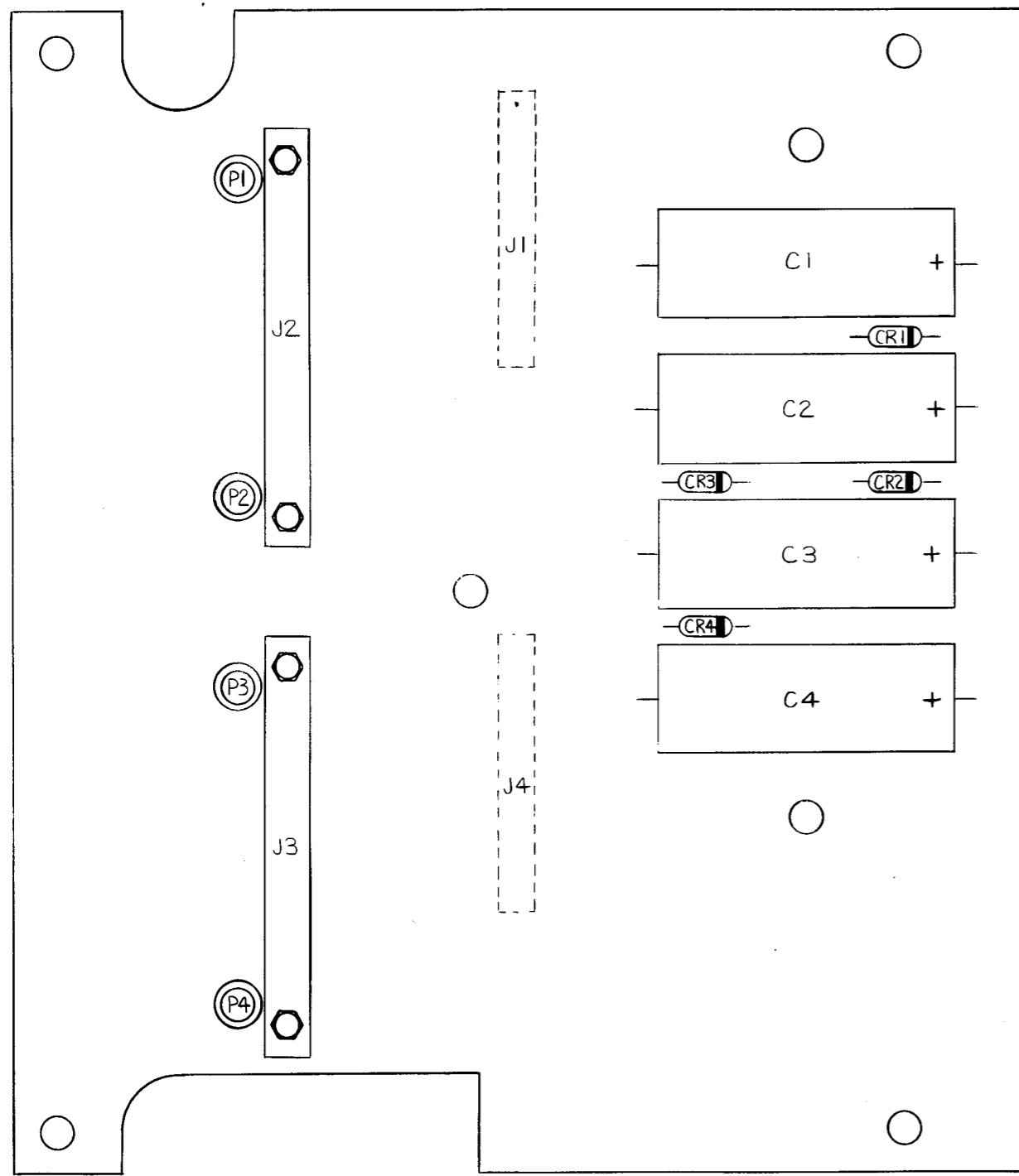

9100A-1608

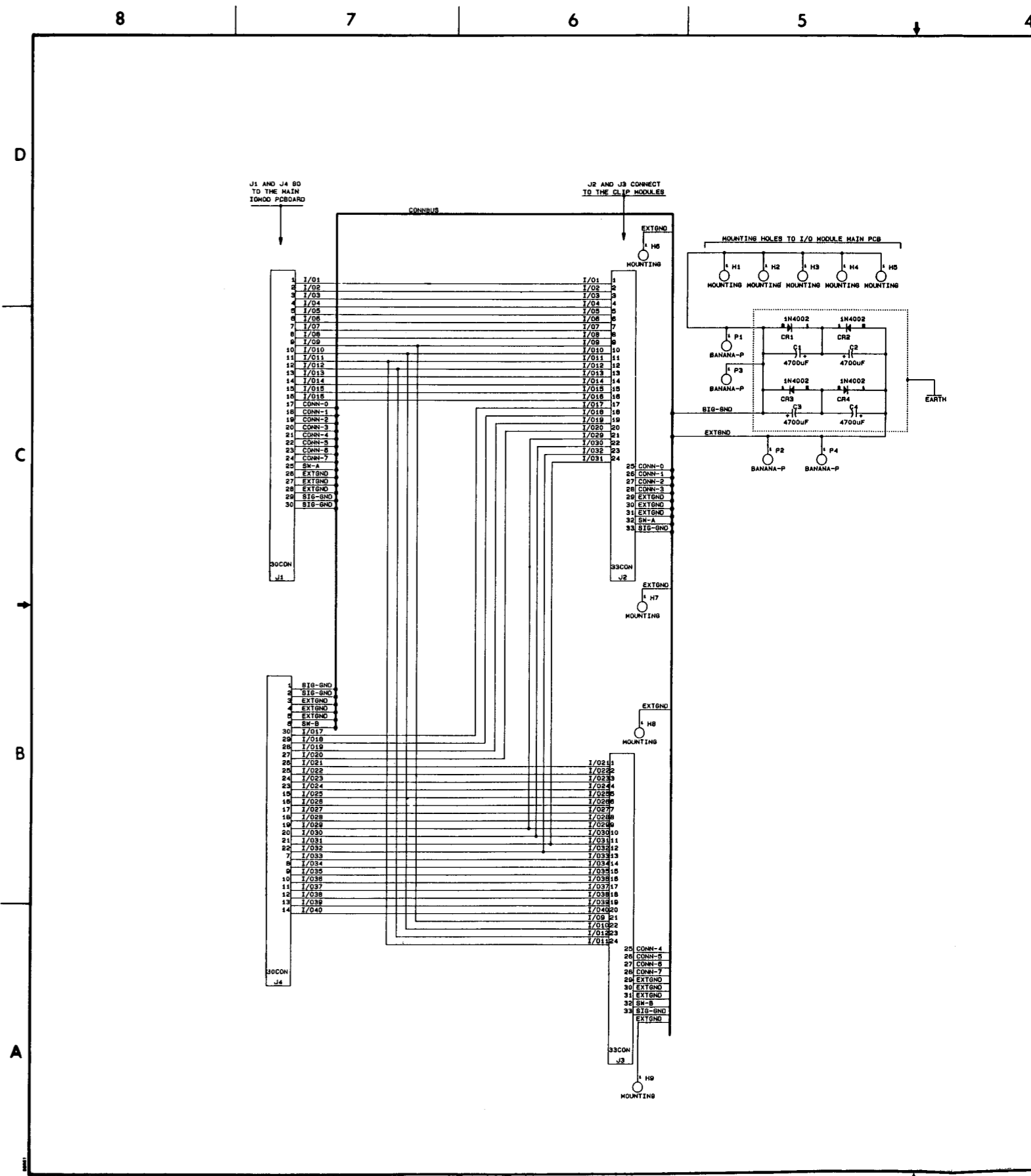

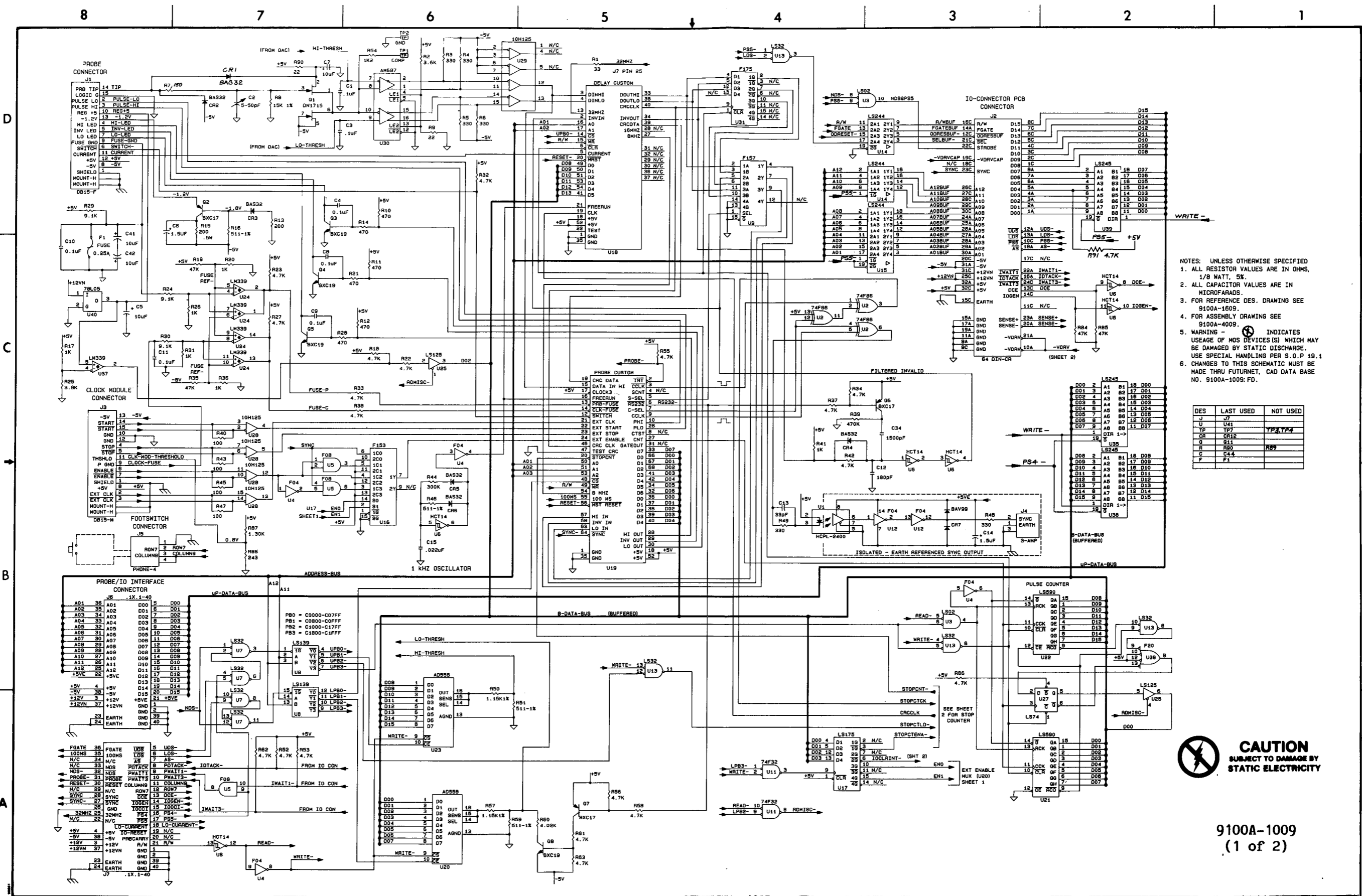

- NOTES: UNLESS OTHERWISE SPECIFIED
1. ALL RESISTOR VALUES ARE IN OHMS, 1/8 WATT, 5%.
 2. ALL CAPACITOR VALUES ARE IN MICROFARADS.
 3. FOR REFERENCE DES. DRAWING SEE 9100A-1609.
 4. FOR ASSEMBLY DRAWING SEE 9100A-4009.
 5. WARNING - INDICATES USAGE OF MOS DEVICES(S) WHICH MAY BE DAMAGED BY STATIC DISCHARGE. USE SPECIAL HANDLING PER S.O.P. 19.1
 6. CHANGES TO THIS SCHEMATIC MUST BE MADE THRU FUTURNET, CAD DATA BASE NO. 9100A-1009: FD.

DES	LAST USED	NOT USED
J	J7	
U	U41	TP3, TP4
CR	CR12	
R	R90	R91
C	C44	
F	F1	

CAUTION
SUBJECT TO DAMAGE BY
STATIC ELECTRICITY

9100A-1009
(1 of 2)

Figure 7-9. A9 Probe I/O PCA

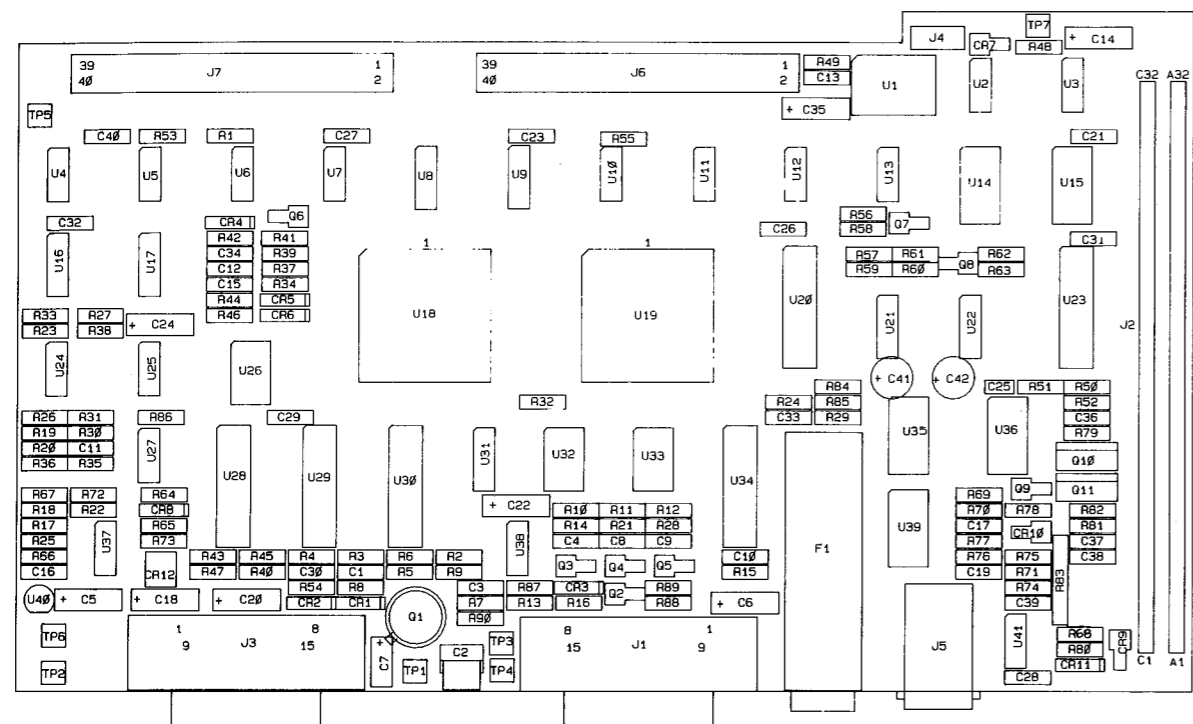

9100A-1609

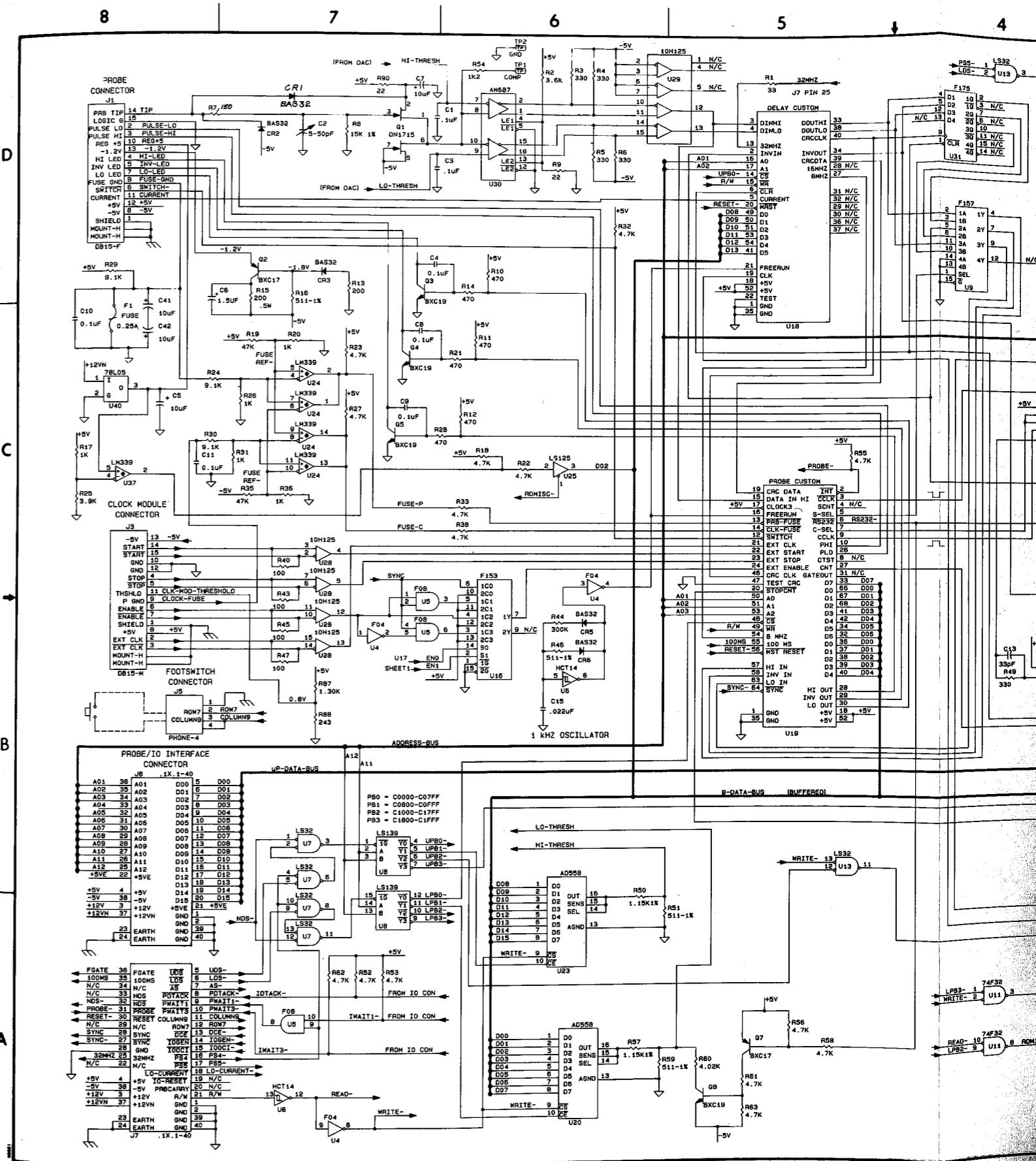

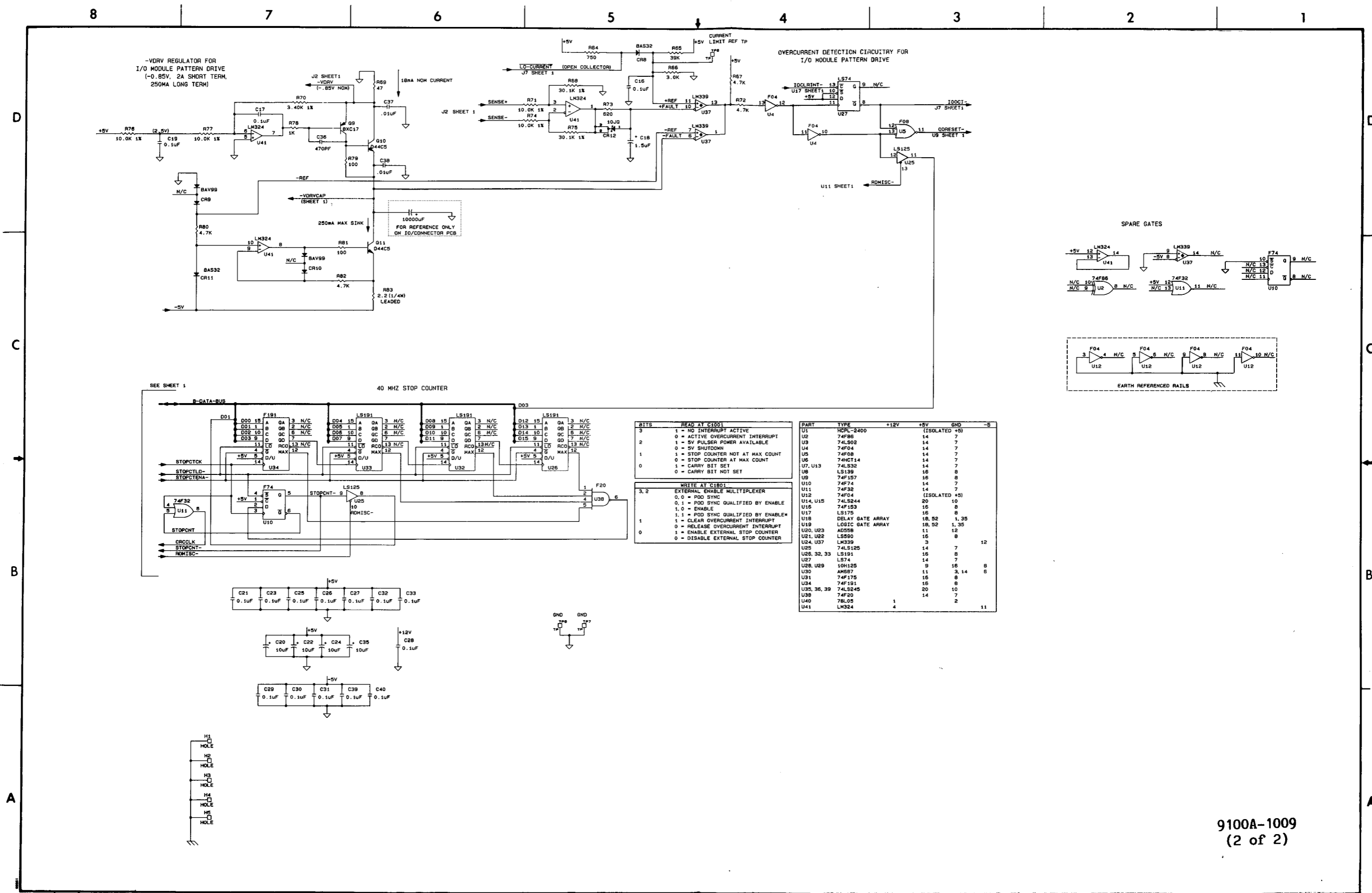

9100A-1009
(2 of 2)

Figure 7-9. A9 Probe I/O PCA (cont.)

D
C
B
A

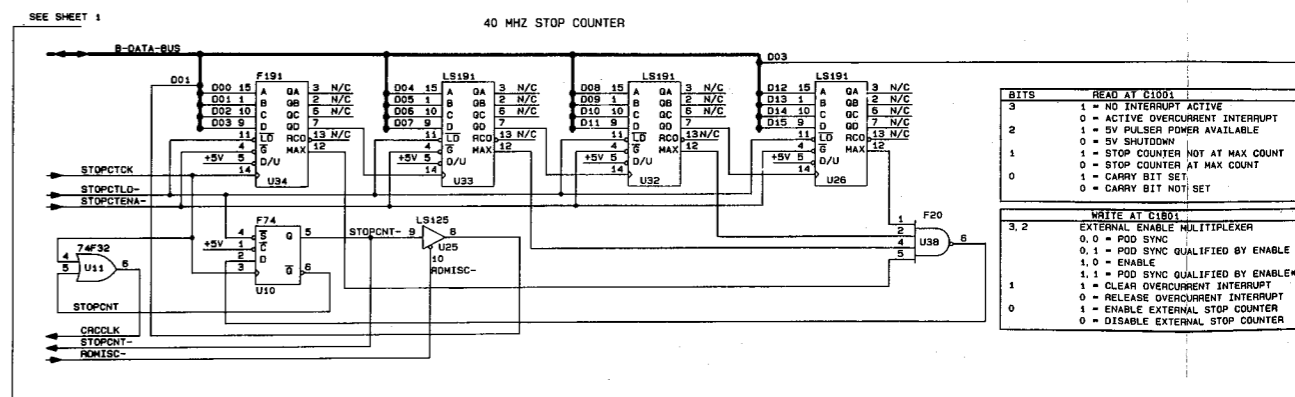
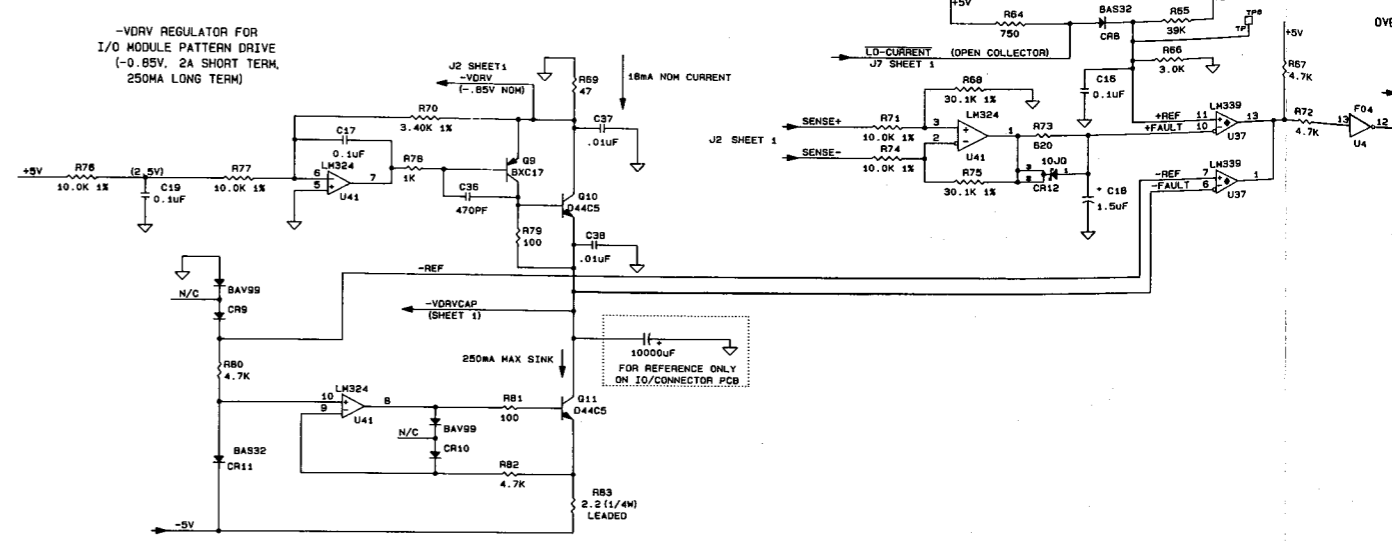

READ AT C1001	
3	1 = NO INTERRUPT ACTIVE
0	0 = ACTIVE OVERCURRENT INTERRUPT
2	0 = 5V PULSER POWER AVAILABLE
1	0 = 5V SHUTDOWN
1	1 = STOP COUNTER NOT AT MAX COUNT
0	0 = STOP COUNTER AT MAX COUNT
0	1 = CARRY BIT SET
0	0 = CARRY BIT NOT SET

WRITE AT C1001	
3, 2	EXTERNAL ENABLE MULTIPLEXER
0, 0	0 = POD SYNC
0, 1	0 = POD SYNC QUALIFIED BY ENABLE
1, 0	1 = ENABLE
1, 1	1 = POD SYNC QUALIFIED BY ENABLE
1	1 = CLEAR OVERCURRENT INTERRUPT
0	0 = RELEASE OVERCURRENT INTERRUPT
1	1 = ENABLE EXTERNAL STOP COUNTER
0	0 = DISABLE EXTERNAL STOP COUNTER

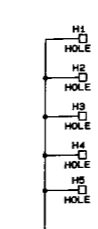
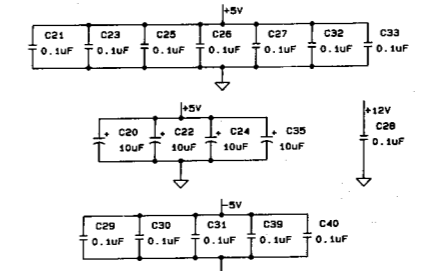

CAUTION
SUBJECT TO DAMAGE BY
STATIC ELECTRICITY

CAUTION
SUBJECT TO DAMAGE BY
STATIC ELECTRICITY

REF	DES	DEVICE	+5V	GND	PACKAGE	QTY
1	U1	88480-8	18	51	18	48
2	U2	NCR 8380	31	11	DIP-40	1
3	U3	PAL-20L8	24	12	DIP-24N	1
4	U4	74LS245	20	10	DIP-20	3
5	U5	74LS373	20	10	DIP-20	2
6	U6	74LS167A	20	10	DIP-24N	1
7	U7	74LS164A	14	7	DIP-14	1
8	U8	74HC164	14	7	DIP-14	1
9	U9	74HC16V	14	7	DIP-14	1
10	RN1, 2	220 OHM SIP	1	-	SIP-10	2
11	RN3, 4	330 OHM SIP	1	-	SIP-10	2
12	RN5	10K OHM SIP	1	-	SIP-10	1
13	R1	LTC-7P	-	2	-	1

NOTES: UNLESS OTHERWISE SPECIFIED
 1. R3 INSTALLED ON 8100A-4010, R11 INSTALLED ON 8105A-008.
 2. NOT INSTALLED ON 9105A-008.
 3. NOT INSTALLED, FOR FUTURE OPTION.
 4. ALL RESISTOR VALUES ARE IN OHMS, 1/4W, 5%.
 5. ALL CAPACITOR VALUES ARE IN MICROFARADS.

WARNING: ⚡ INDICATES USAGE OF MOS DEVICES WHICH MAY BE DAMAGED BY STATIC DISCHARGE. HANDLING PER S.O.P. 19.1

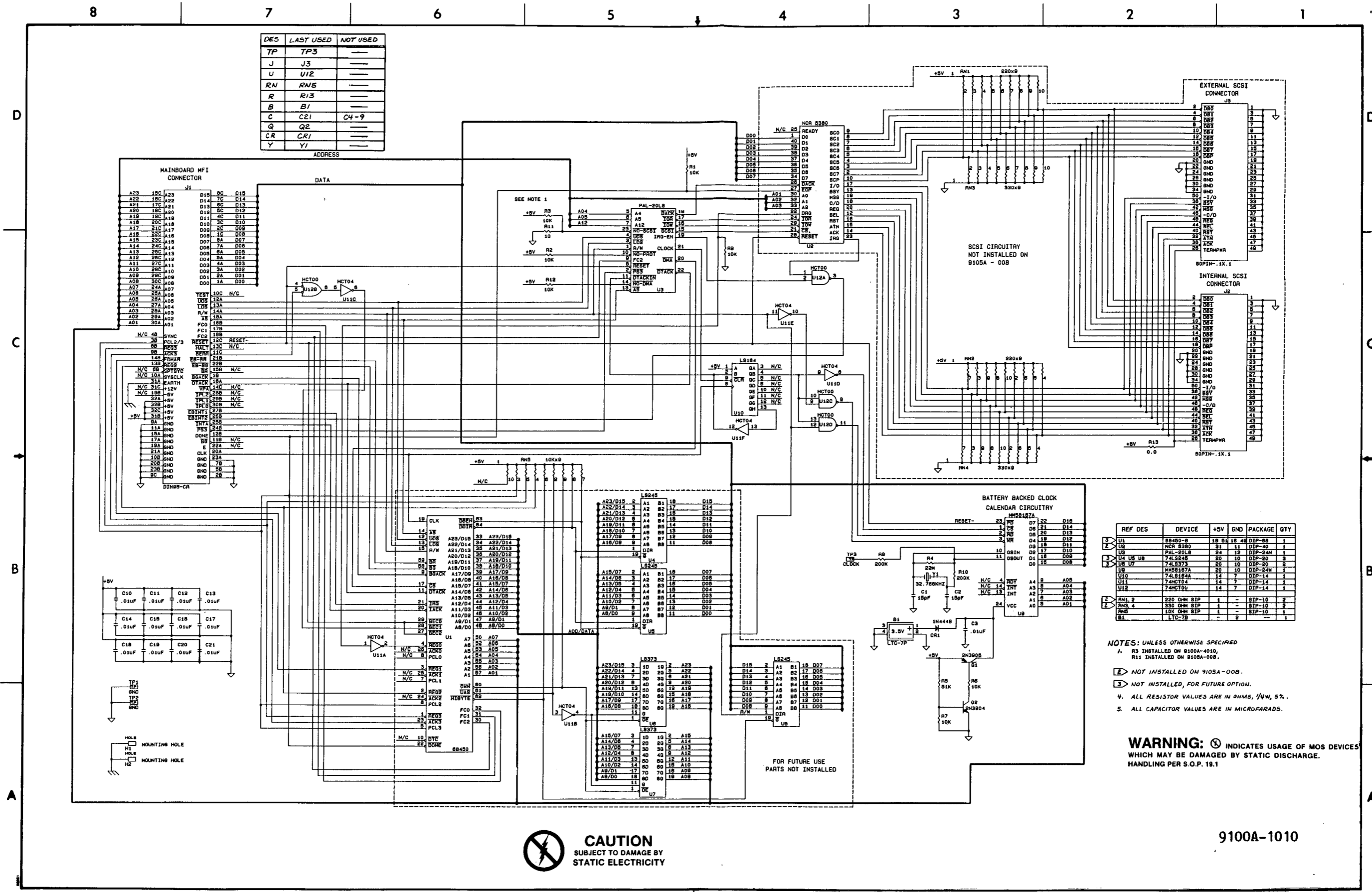

J7 FORM A1960 Rev. 2-82

Figure 7-10. A10 Multi-Function Interface PCA

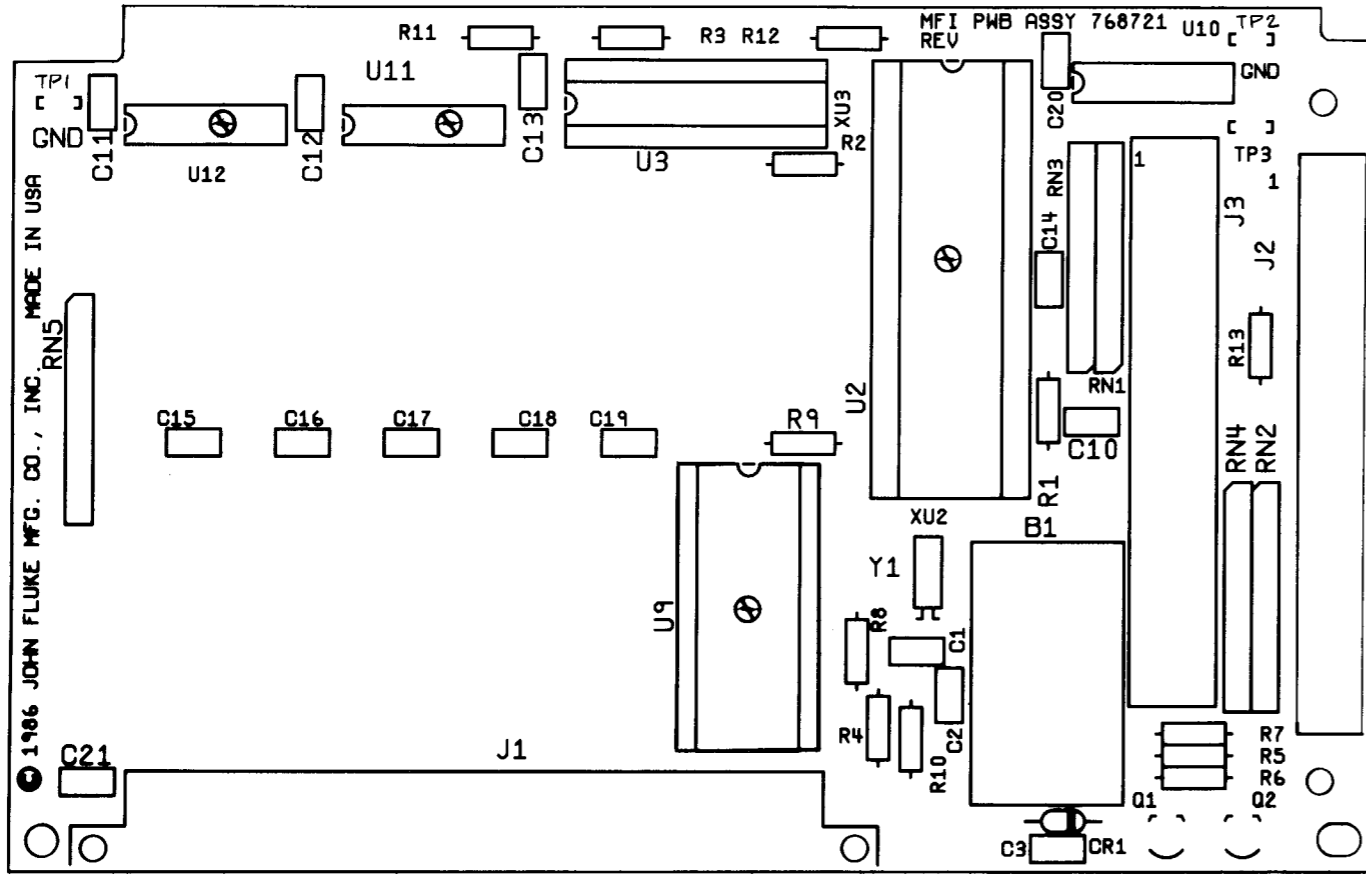

© 1986 JOHN FLUKE MFG. CO., INC. MADE IN USA JOHN FLUKE MFG. CO., INC. RNS

9100A-1610

CAUTION
SUBJECT TO DAMAGE BY
STATIC ELECTRICITY

8 7 6 5 4

D
C
B
A

DES	LAST USED	NOT USED
TP	TP3	---
J	J3	---
U	U12	---
RN	RN5	---
R	R13	---
B	B1	---
C	C21	CH-9
Q	Q2	---
C.R	CR1	---
Y	Y1	---

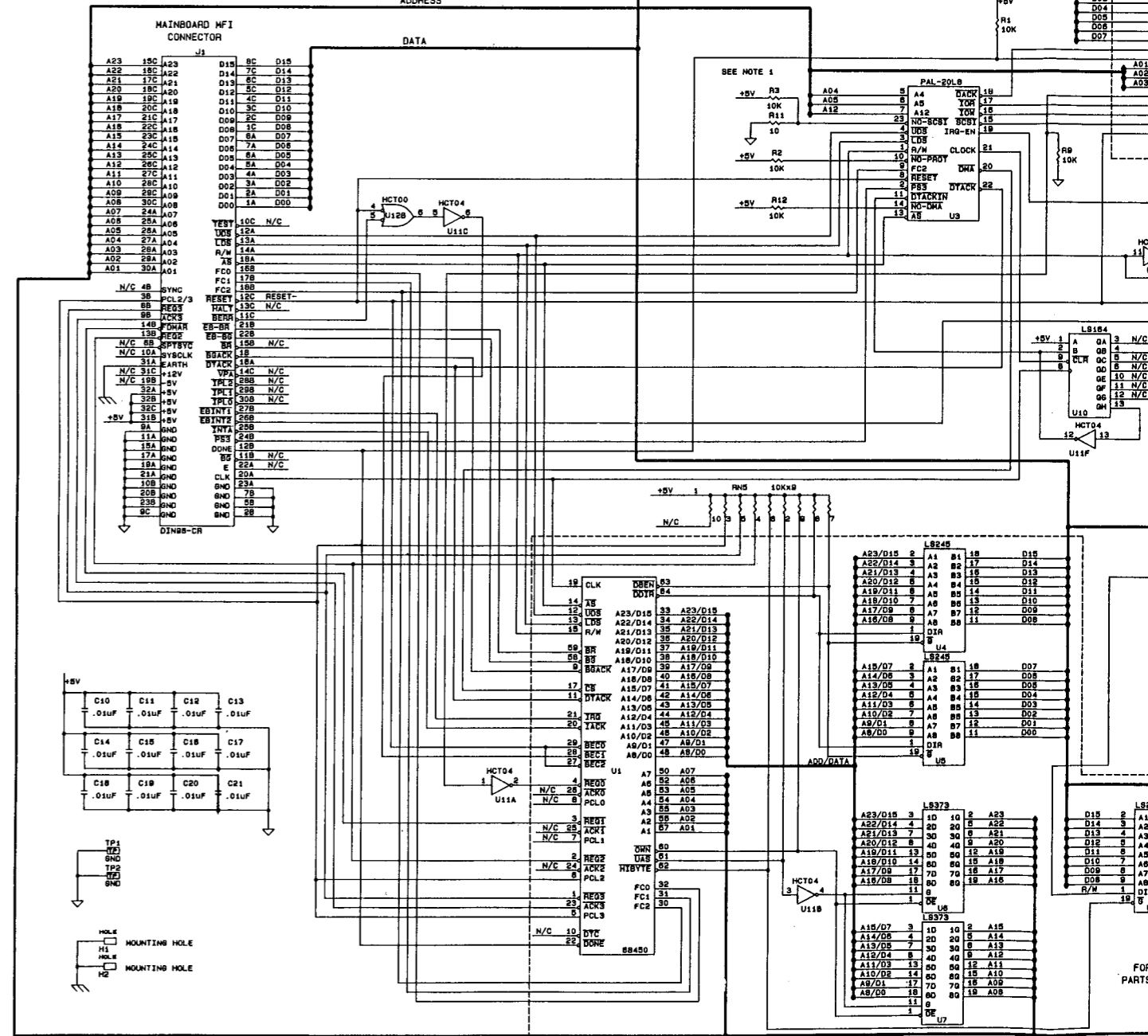

CAUTION
SUBJECT TO DAMAGE BY
STATIC ELECTRICITY

8 7 6 5 4 3 2 1

D
C
B
A

D
C
B
A

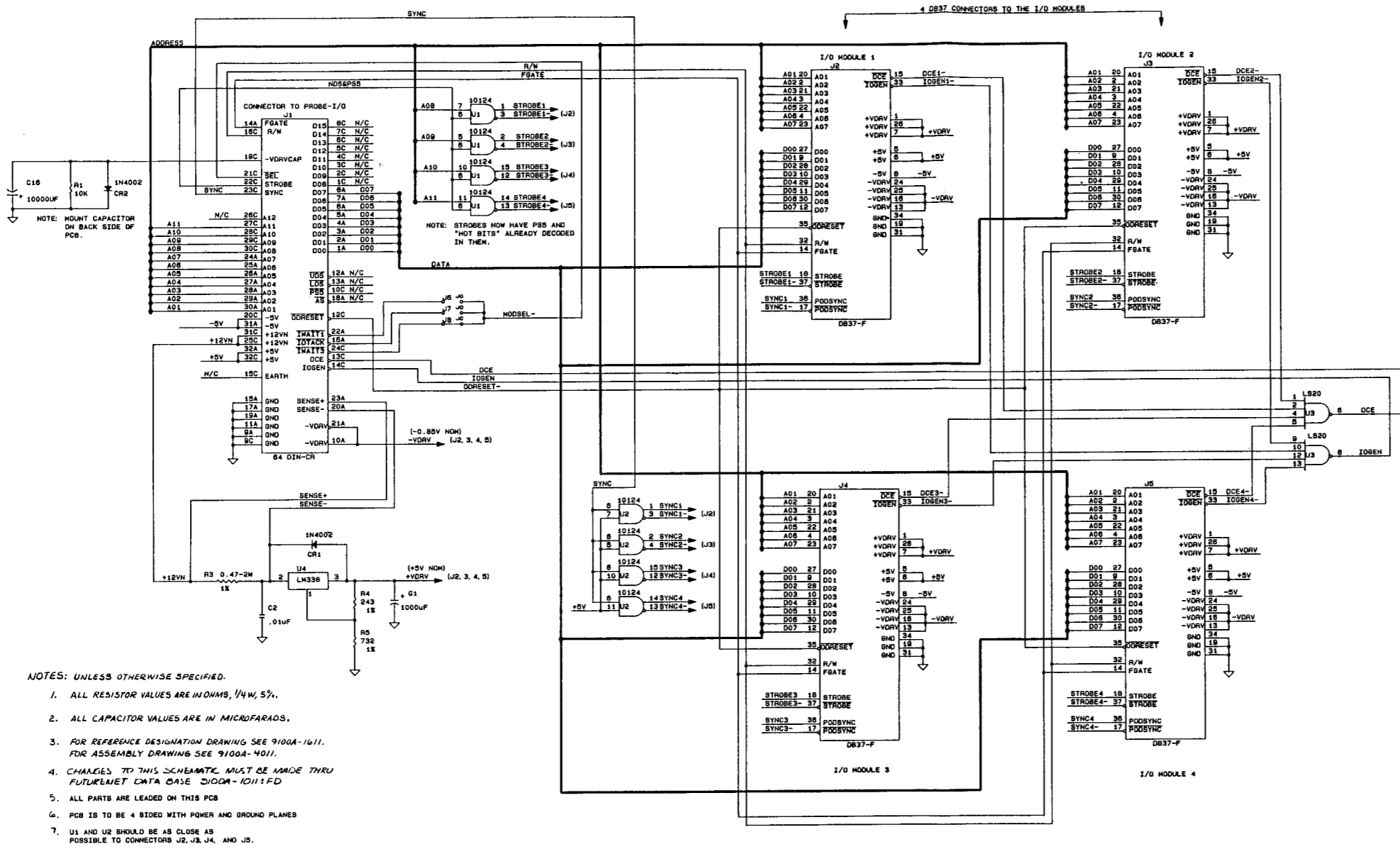

REF DES	DEVICE	+5V	GND	-5V	+12V	PACKAGE	QTY
U1, 2	10124	8	18	8		18-DIP	2
U3	LM339	14	7			14-DIP	1
U4	LM339					TO-3	1

DES	LAST USED	NOT USED
J	J8	
U	U4	
C,R	C,R2	
Z	Z5	
R	R5	R2
C	C17	

- NOTES: UNLESS OTHERWISE SPECIFIED.
1. ALL RESISTOR VALUES ARE IN OHMS, 1/4W, 5%.
 2. ALL CAPACITOR VALUES ARE IN MICROFARADS.
 3. FOR REFERENCE DESIGNATION DRAWING SEE 9100A-1011. FOR ASSEMBLY DRAWING SEE 9100A-4011.
 4. CHANGES TO THIS SCHEMATIC MUST BE MADE THRU FUTURE MET DATA BASE DDDA-1011:FD
 5. ALL PARTS ARE LEADED ON THIS PCB
 6. PCB IS TO BE 4 SIDED WITH POWER AND GROUND PLANES
 7. U1 AND U2 SHOULD BE AS CLOSE AS POSSIBLE TO CONNECTORS J2, J3, J4, AND J5.

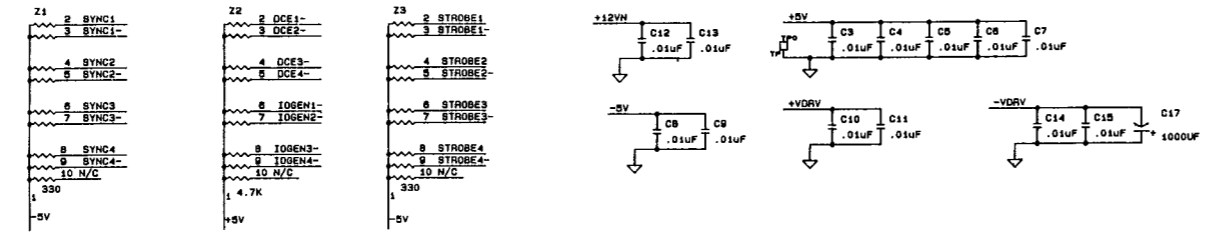

9100A-1011

J.F. FORM 4450 Rev. 2-82

Figure 7-11. A11 I/O Connector PCA

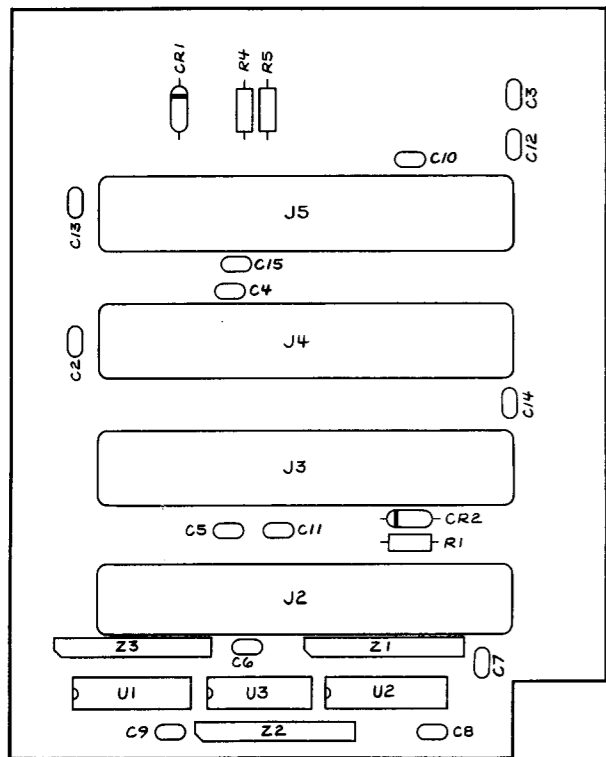

CKT 4 SIDE

9100A-1611

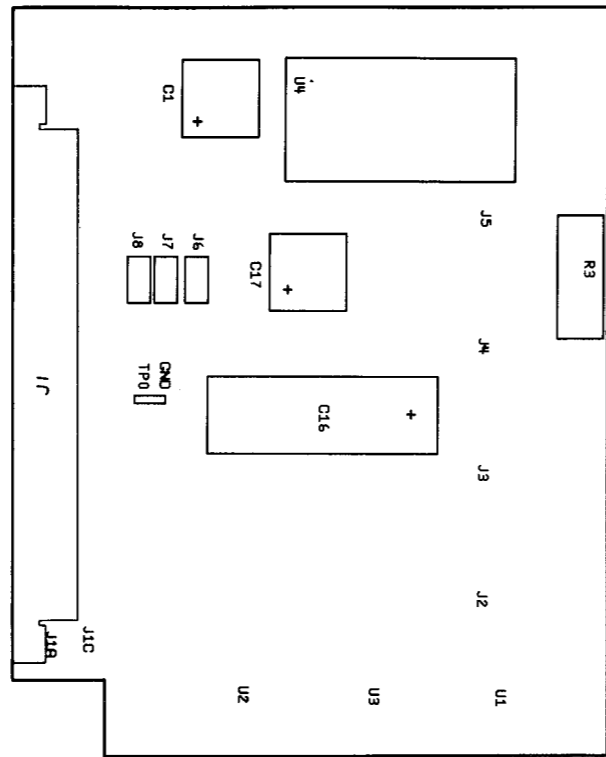

CKT 1 SIDE

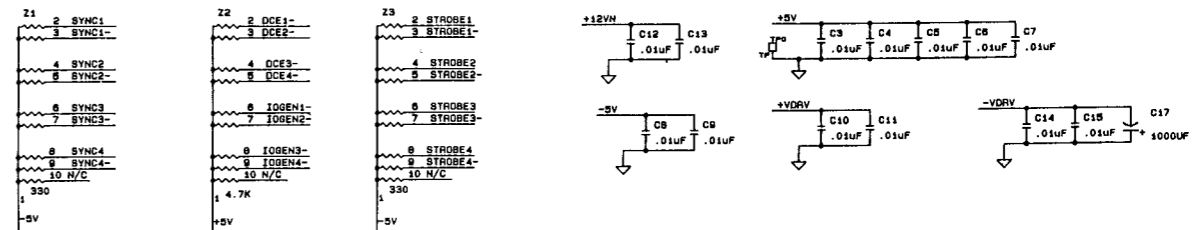
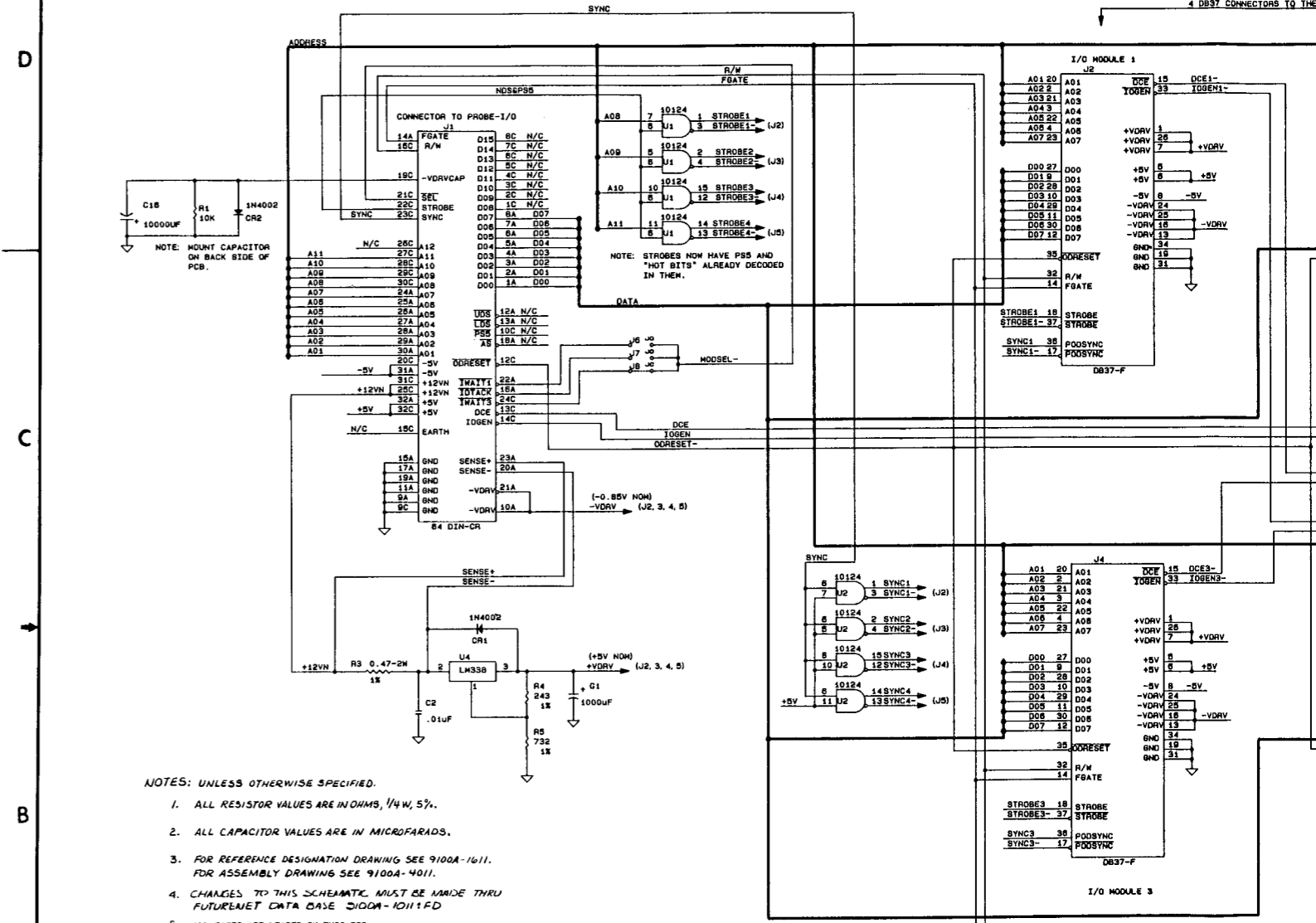

8

7

6

5

4

D

C

B

A

CABLE AND CLIPS

24 PIN IXT CABLE
SHOWN FOR REFERENCE ONLY

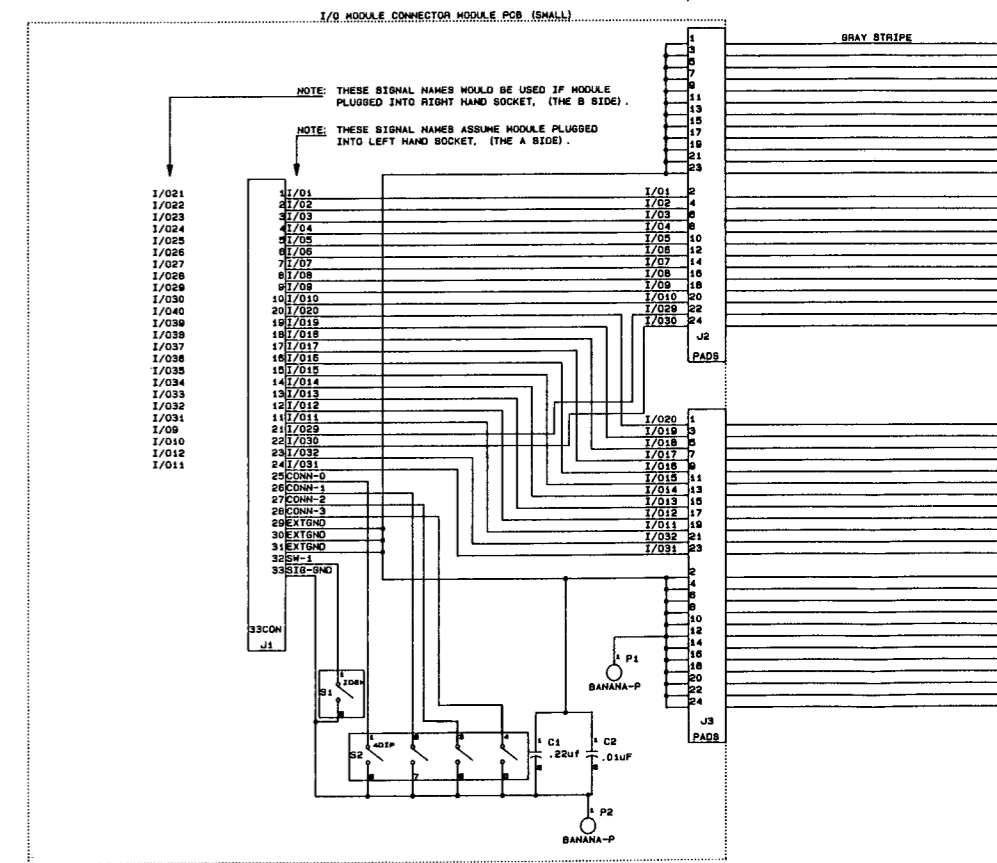

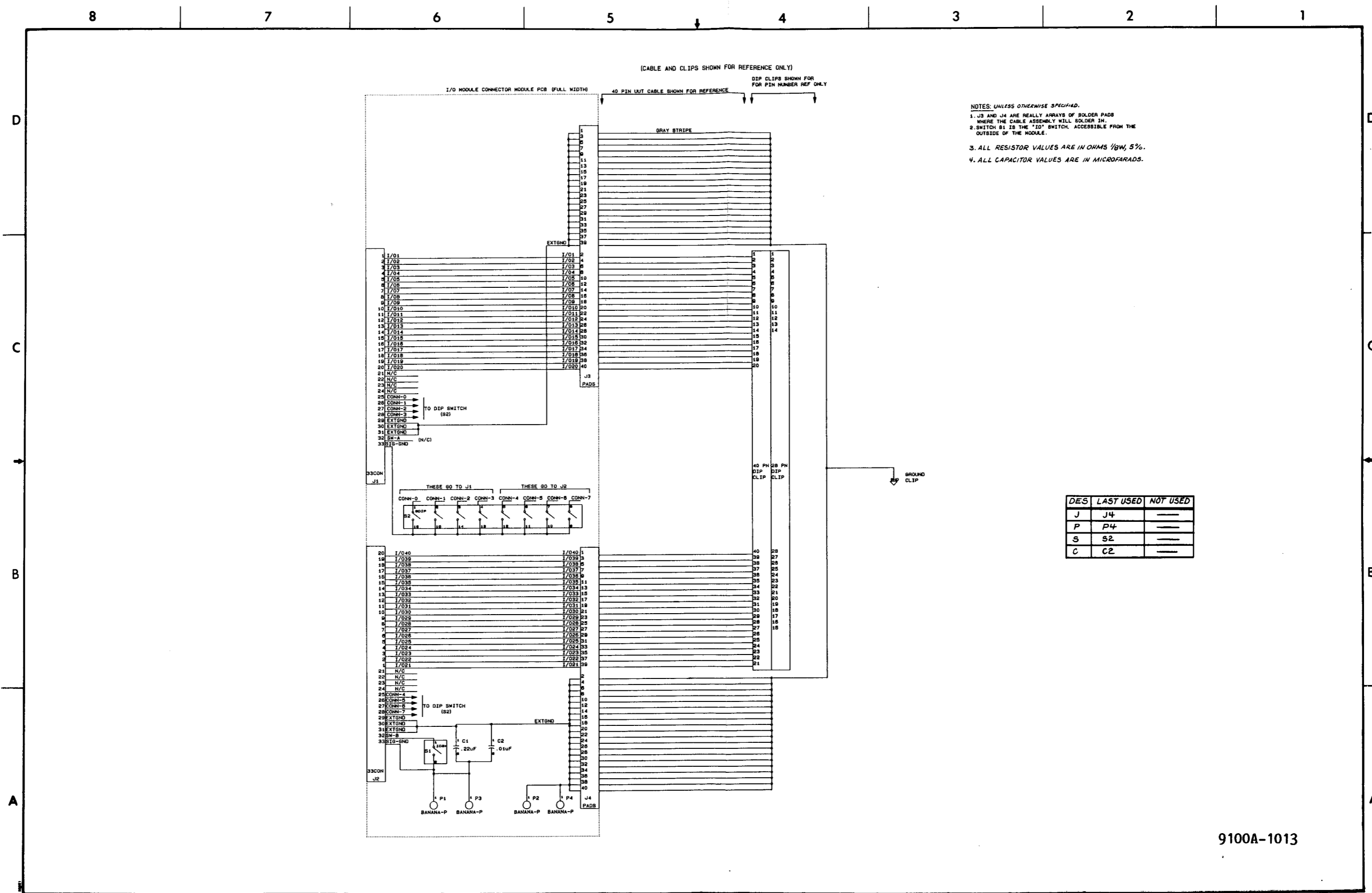

9100A-1013

J1 FORM A1560 Rev 7-82

Figure 7-13. A13 DIP Clip Module (Full)

8

7

6

5

4

3

2

1

NOTES: UNLESS OTHERWISE SPECIFIED.

1. ALL RESISTOR VALUES ARE IN OHMS, 1/8W, 5%.
2. ALL CAPACITOR VALUES ARE IN MICROFARADS.
3. FOR ASSEMBLY DRAWING SEE 9100A-4014.
4. CHANGES TO THIS SCHEMATIC MUST BE MADE THRU FUTURENET, CAD DATA BASE NO. 9100-1014:FD.

DES	LAST USED	NOT USED
J	J2	
P	P4	
S	S1	
E	E1	

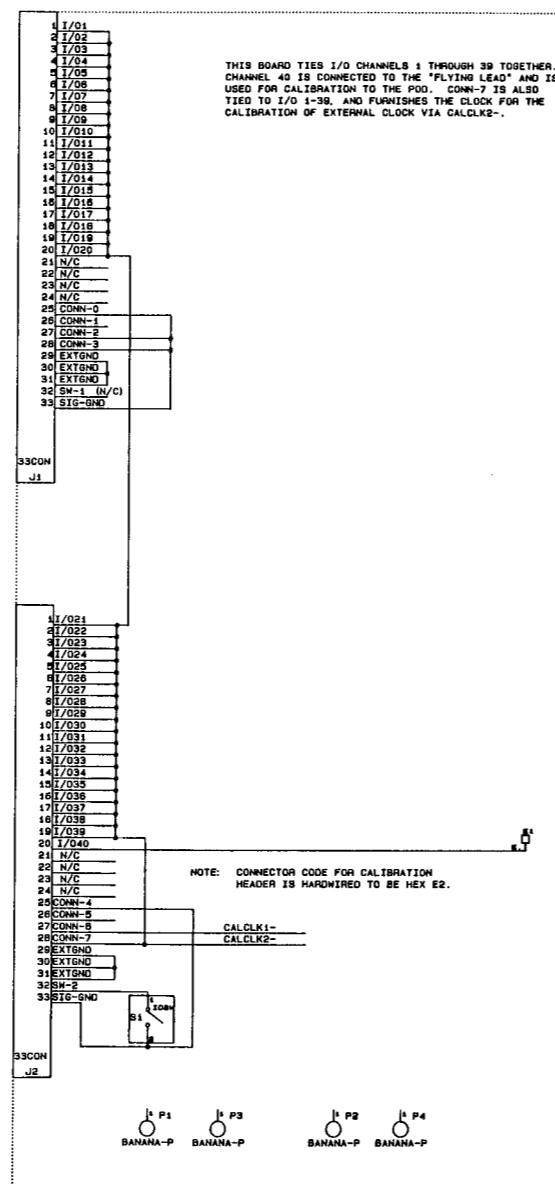

9100A-1014

Figure 7-14. A14 Calibration Module PCA

- NOTES: UNLESS OTHERWISE SPECIFIED.**
1. ALL RESISTOR VALUES ARE IN OHMS, 1/8W, 5%.
 2. ALL CAPACITOR VALUES ARE IN MICROFARADS.
 3. FOR ASSEMBLY DRAWING SEE 9100A-4014.
 4. CHANGES TO THIS SCHEMATIC MUST BE MADE THRU FUTURENET, CAD DATA BASE NO. 9100-1014:FD.

DES	LAST USED	NOT USED
J	J2	
P	P4	
S	S1	
E	E1	

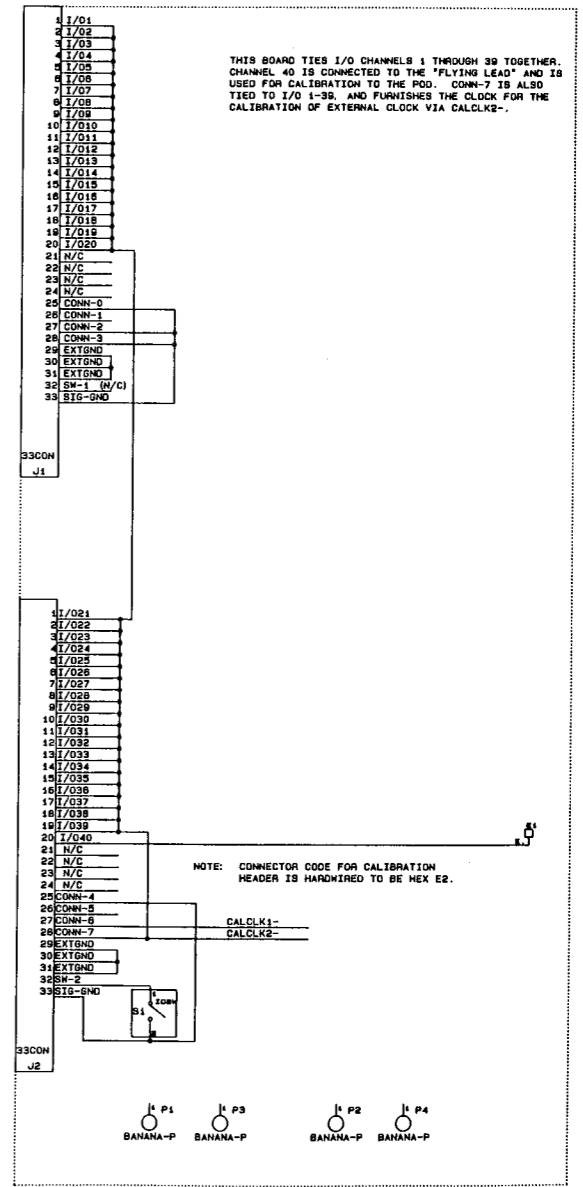

D

C

B

A

8 7 6 5 4 3 2 1

NOTES: UNLESS OTHERWISE SPECIFIED

1. ALL CAPACITOR VALUES ARE IN MICROFARADS.
2. FOR REFERENCE DESIGNATION DRAWING SEE 9100A-1616,
FOR ASSEMBLY DRAWING SEE 9100A-4016.
3. CHANGES TO THIS SCHEMATIC MUST BE MADE THRU
FUTURENET, CAD DATA BASE NO. 9100A-1016:FD.
4. **WARNING:** ⚡ INDICATES USAGE OF MOS DEVICE(S)
WHICH MAY BE DAMAGED BY STATIC DISCHARGE. USE SPECIAL
HANDLING PER S.O.P. 19.1

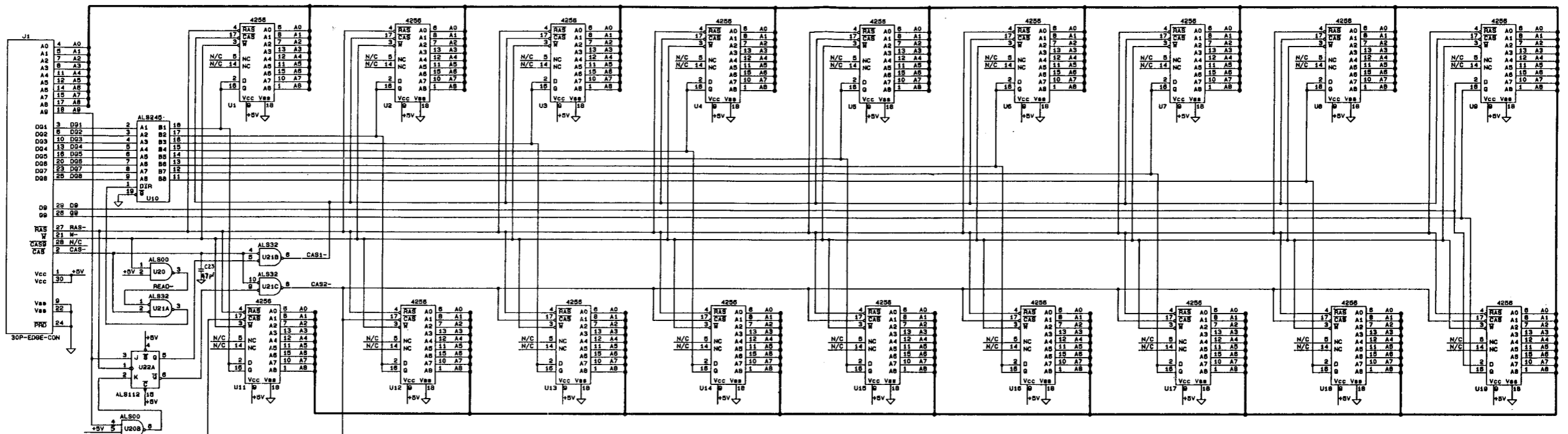

DES	LAST USED
J	J1
U	U22
C	C23

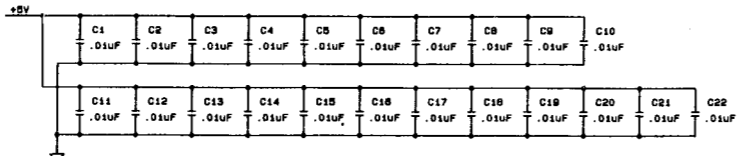

CAUTION
SUBJECT TO DAMAGE BY
STATIC ELECTRICITY

9100A-1016

J.F. FORM 44500 Rev. 2 82

Figure 7-15. A16 512K RAM Module

- NOTES: UNLESS OTHERWISE SPECIFIED
1. ALL CAPACITOR VALUES ARE IN MICROFARADS.
 2. FOR REFERENCE DESIGNATION DRAWING SEE 9100A-1616, FOR ASSEMBLY DRAWING SEE 9100A-4016.
 3. CHANGES TO THIS SCHEMATIC MUST BE MADE THRU FUTURENET, CAD DATA BASE NO. 9100A-1016:FD.
 4. **WARNING:** ⚡ INDICATES USAGE OF MOS DEVICE(S) WHICH MAY BE DAMAGED BY STATIC DISCHARGE. USE SPECIAL HANDLING PER S.O.P. 19.1

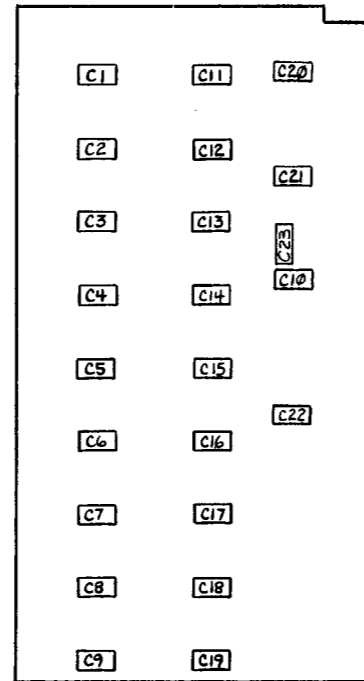
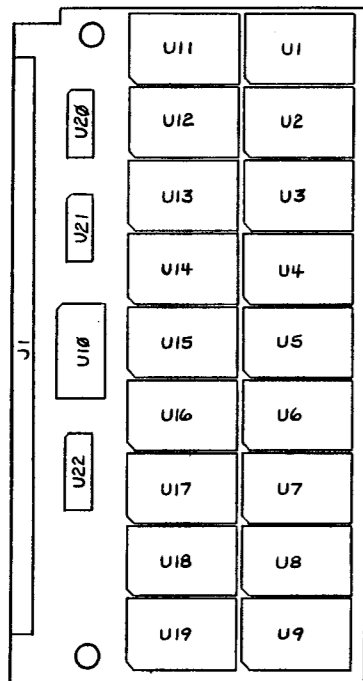

9100A-1616

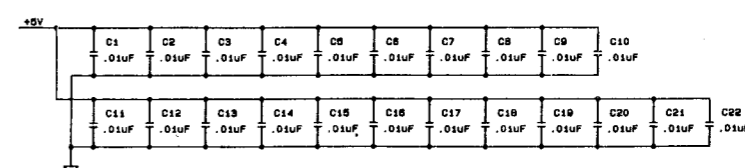
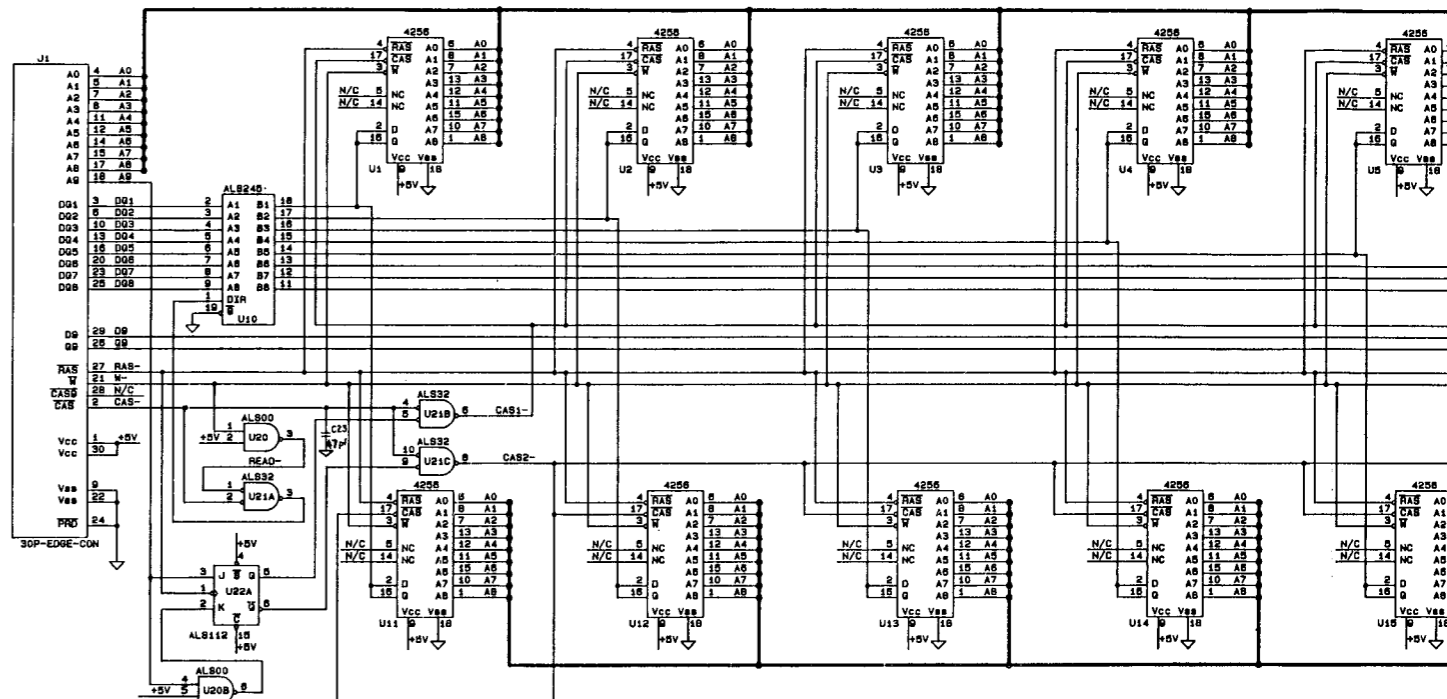

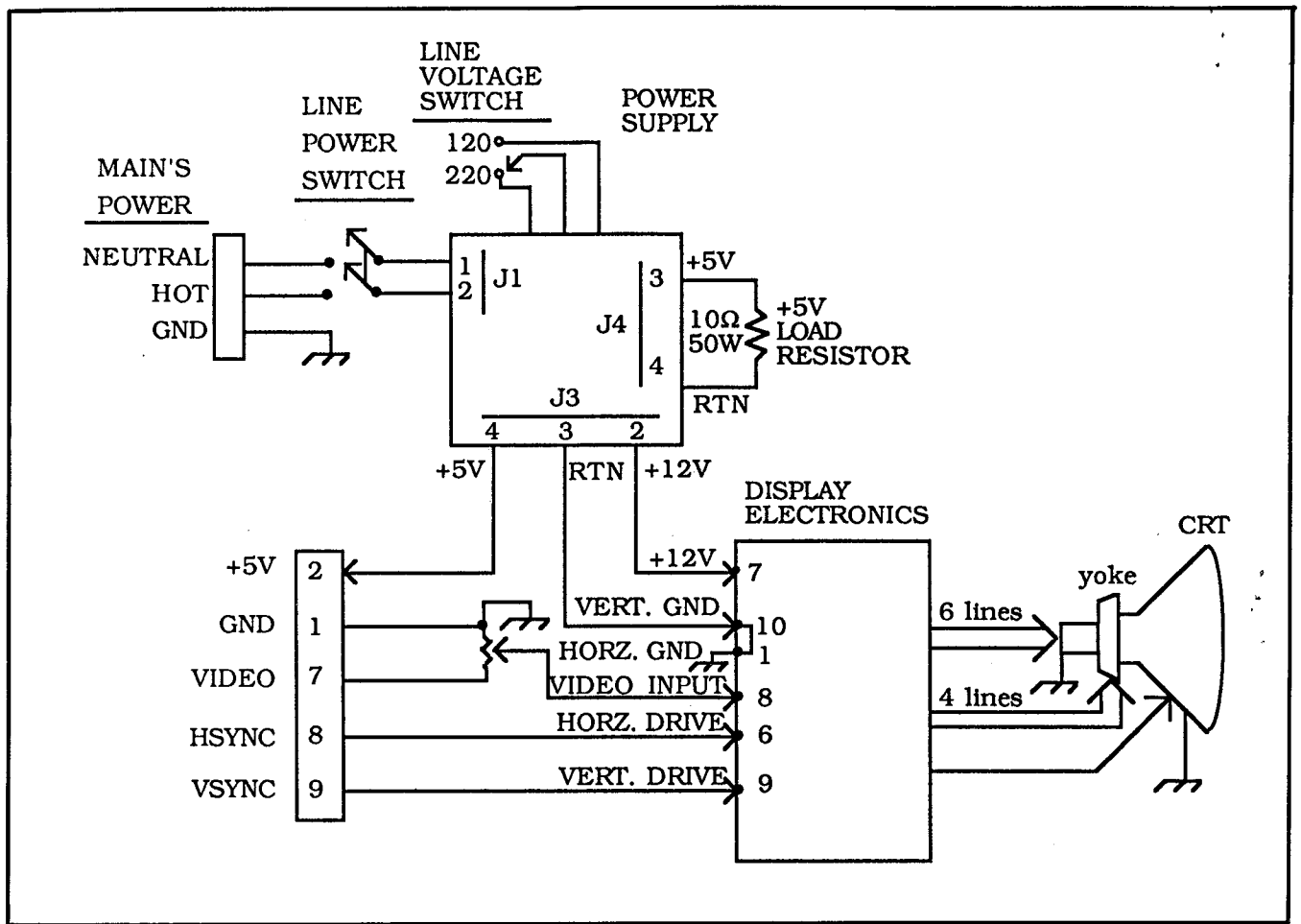

Figure 7-16. A19 Monochrome Monitor, Block Diagram

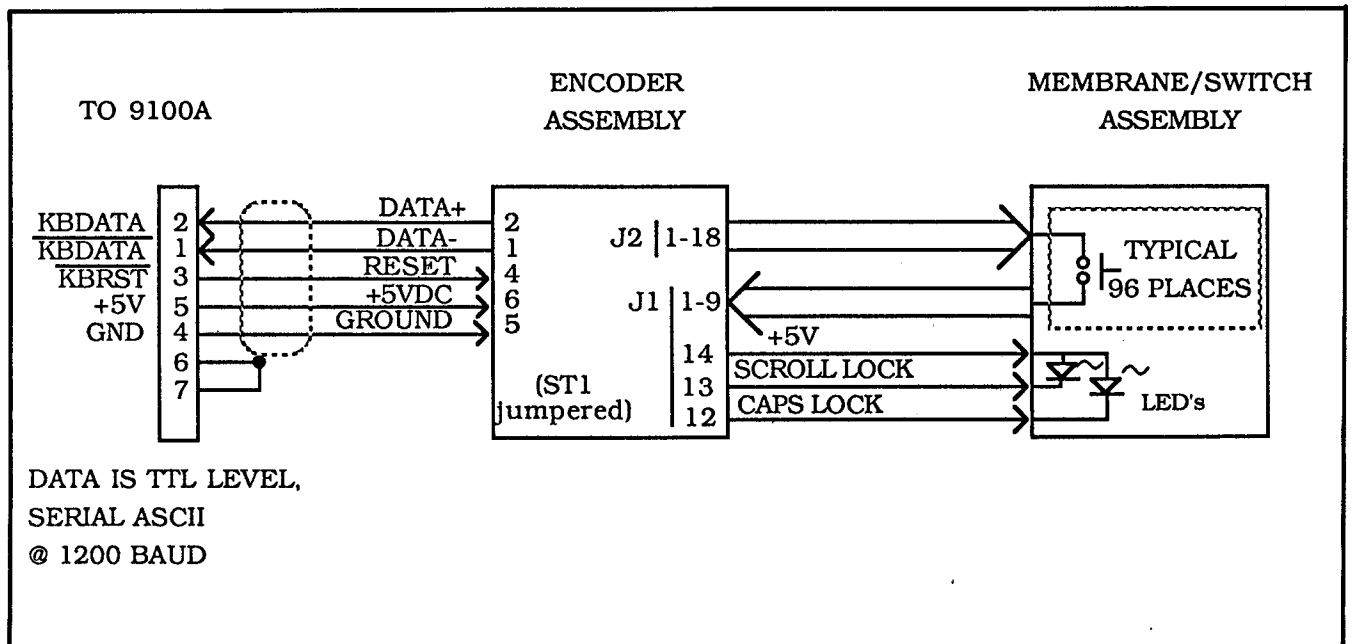

Figure 7-17. -013 Programmer's Keyboard, Block Diagram

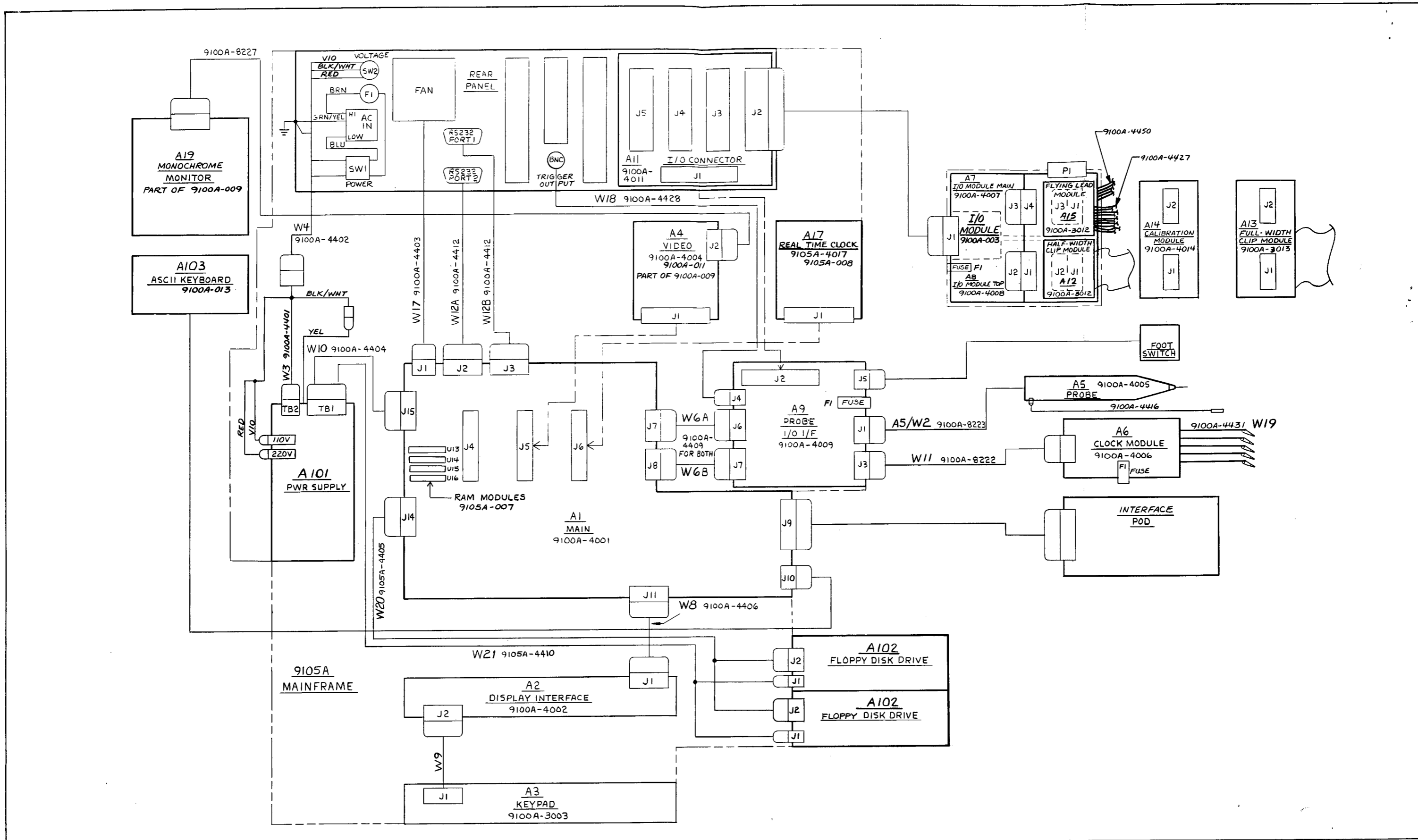

Figure 7-19. Interconnect Diagram, 9105A

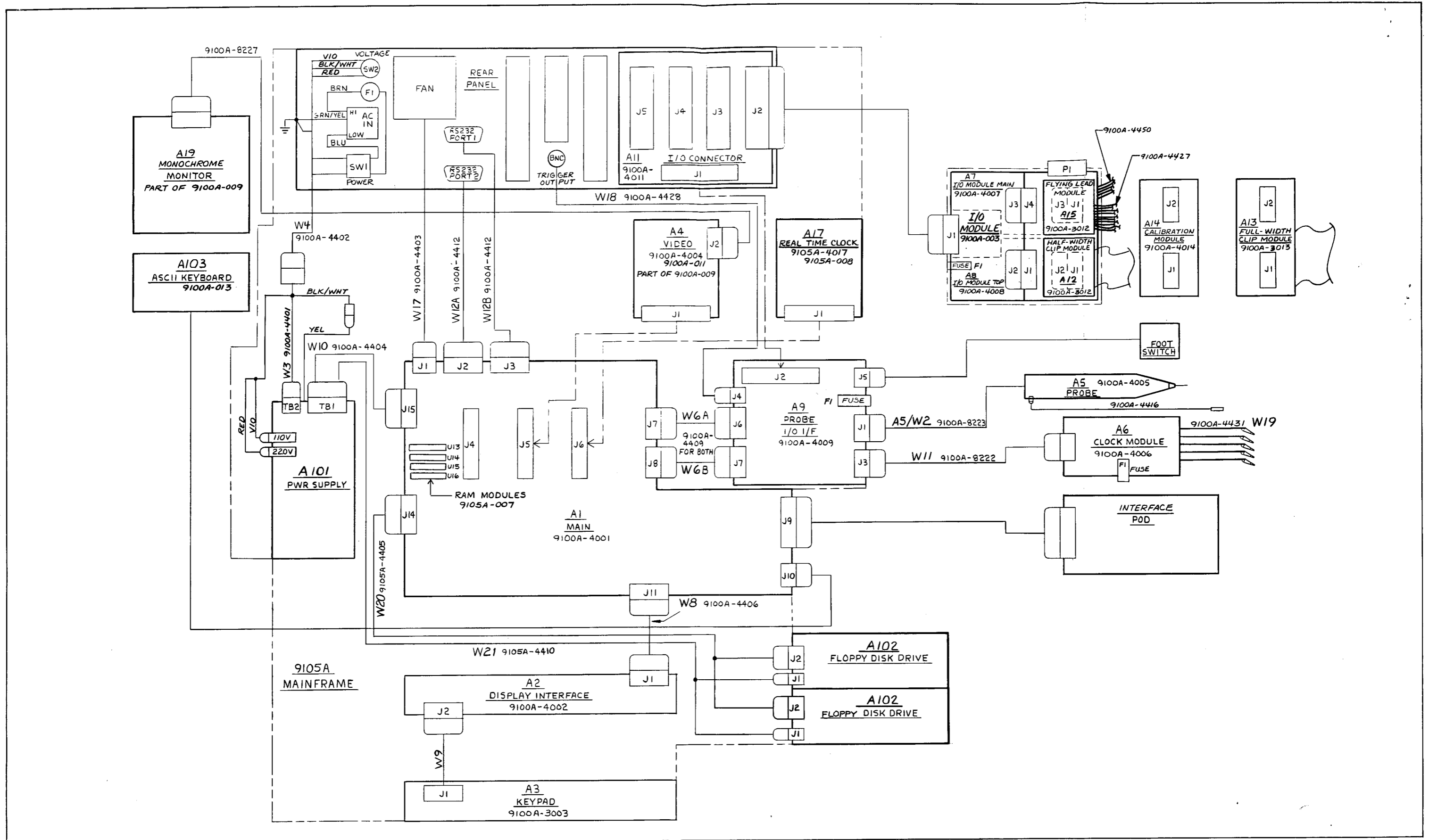

Figure 7-19. Interconnect Diagram, 9105A

INDEX

68000 Pin Assignments, 3-15
9100A Block Diagram, 3-6
9100A System, 4-10
9105A Block Diagram, 3-7
9105A System, 4-11

Access, Mainframe , 4-9
Access, Monitor, 4-19
Access, Operator Keypad/Display, 4-12
Accessories, 2-7
Address Bus, 3-13
Address Decoding Example, 3-72
Address Decoding, 3-24
Address Ranges, 3-14
Addresses, 3-64
Addressing, 3-70
Annunciators, 3-42
Asynchronous Execution, 3-23

Bus Arbitration, 3-16
Bus Error and Halt, 3-16
Bus Interface Timing Diagram, 3-74
Bus Interface, 3-70
Butt-Soldered DIP, 4-56

CRT and Yoke, Installation, 4-30
CRT and Yoke, Removal, 4-28
CRT, Replacement, 4-37
Calibration Data, Invalid , 4-52
Calibration Data, Restoring , 4-53
Calibration Data, Saving , 4-52
Calibration Data, Saving and Restoring , 4-51
Calibration Module Configuration Codes, 3-82
Calibration Module PCA, 7-23
Calibration Module, 3-85
Calibration, 4-45
Characters, Displayable , 3-38
Chip Channel Input, 3-84

Index

Chip Pattern Drive Output, 3-84
Chip Soldering, 4-63
Cleaning, 4-8
Cleaning, Fan Filter, 4-9
Cleaning, Floppy Disk Drive, 4-9
Clip Configuration Switch Settings, 4-72
Clock Module Interface, 3-50
Clock Module PCA, 7-13
Clock Module, 3-8, 3-63
Clock and Enable Mux, 3-75
Clock, 3-64
Connections, External , 2-3
Connector Codes, 3-83
Control Characters, 3-41
Control Register, 3-57, 3-77
Custom Chip Pin Description, 3-76
Custom Chip Selection, 3-73
Custom Chip Voltage Level Detection, 3-80
Custom Chip, 3-75
Custom Delay Chip, 3-50
Custom Logic Chip, 3-51

DIP Clip Module (Full), 7-22
DIP Clip Module (Half), 7-21
DIP Clip, 3-85
DTACK, 3-24
DTIO #1 (Channels A, B), 3-32
DTIO #2 (Channels C, D), 3-33
DTIO, 3-5, 3-30
Data Bus Buffers, 3-56
Data Bus, 3-13
Data Comparison Inputs, 3-78
Data Comparison and General Interrupts, 3-78
Data Strobe Control, 3-12
Dip-Clip Configuration Codes, 3-82
Disassembly, 4-15
Disassembly, Disk System, 4-14
Disk Drive Assemblies, Installation , 4-14
Disk Drive Assemblies, Removal, 4-14
Disk Drive, 3-33
Disk System, Disassembly, 4-14
Display Adjustment Locations, External, 4-35
Display Characters, 3-39
Display Interface PCA, 7-7
Display PCA, 4-27
Display Self Test, 4-43

Exception Processing, 3-17

FET Output, 3-83
Floppy Controller Addressing, 3-34
Floppy Disk Jumper Settings, 4-69
Floppy Drive Control Latch Outputs, 3-34
Floppy Drive Controller, 3-33
Flying Lead Module Configuration Switch Settings, 4-72
Footswitch Connector, 3-56
Full-Width Clip Module, 3-86
Fuse Changing, Clock Module, 4-7
Fuse Changing, I/O Module, 4-8
Fuse Changing, Mainframe, 4-7
Fuse Changing, Probe , 4-7
Fuse Detection, 3-78
Fuse Part Numbers, 4-8

General Control Latch, 3-77

Half Width Clip Module, 3-86
Hard Disk Controller, Removal , 4-14
Hard Disk System, 3-8, 3-35
Hot-Bit Decoding Examples, 3-73

I/O Connector Interface PCA, Removal, 4-16
I/O Connector Interface, 3-57
I/O Connector PCA, 7-20
I/O Module (Main) PCA, 7-14
I/O Module (Top) PCA, 3-85, 7-16
I/O Module -VDRV Voltage Regulator, 3-54
I/O Module Address Decoding, 3-71
I/O Module Command Register, 3-79
I/O Module Interface Connector, 3-53
I/O Module Overcurrent Detection, 3-55
I/O Module Self Test, 4-42
I/O Module, 3-69
I/O Module, 3-9, 3-68
Input Protection, 3-83
Installation, Disk Drive Assemblies, 4-14
Interconnect Diagram, 9100A, 7-25
Interconnect Diagram, 9105A, 7-26
Interface Pods, 2-7
Interrupt Vector Table, 3-19
Interrupts, 3-18

Key Values, 3-43
Keyboard, Programmer's, 3-67
Keypad PCA, 7-9
Keypad, Disassembly, 4-13

Level Indicator Operation, 3-62
Level Indicators, 3-62
Line Voltage, Mainframe , 4-3
Line Voltage, Monitor, 4-6
Logic Level Modes, 3-62
Logic Levels of NDRV and PDRV, 3-84

Index

MFI and Video Controller PCA Removal, 4-16
Main PCA (MC68000 Microprocessor), 3-9
Main PCA, 3-5, 7-3
Main PCA, Removal , 4-16
Main PCA, Signal and Pin Description, 3-9
Manual Set, 1-5
Metal Electrode Face (MELF), 4-56
Microfloppy Disk System, 3-5, 3-33
Microprocessor Status Latches, 3-20
Monitor Alignment Program, 4-33
Monitor Display PCA, 4-24
Monitor Display PCA, Installation, 4-26
Monitor Display PCA, Removal, 4-24
Monitor Rear Panel, 4-20
Monitor, 3-8, 3-67
Monitor, Access, 4-19
Monitor, Adjustment, 4-32
Monitor, Cover Removal, 4-19
Monitor, Front Bezel Removal, 4-19
Monitor, Power Supply Installation, 4-22
Monitor, Power Supply Removal, 4-21
Monitor, Power Supply, 4-21
Multi-Function Interface PCA, 7-19
Multi-Function Interface, 3-63

Notation Conventions, 1-6

Operator Keypad/Display, Removal, 4-12
Operator Keypad/Display, Separation, 4-12
Operator's Display, 3-8, 3-35
Operator's Keypad, 3-8, 3-42
Options, 2-6
Oscilloscope Use in Probe Compensation, 4-47

PLCC Lead Index, 4-59
PLCC Soldering, 4-63
Parts, Replaceable, 5-1
Plastic Leaded Chip Carrier (PLCC), 4-55
Pod Control Port Bit Assignment, 3-27
Pod Interface Pinout, 3-29
Pod Interface, 3-27
Pod Self Test, 4-41
Power Requirements, 2-3
Power Supply Lead Connections, 4-23
Power Supply Pinout, 3-35
Power Supply Removal, 4-14
Power Supply, 3-8, 3-35
Power-Up Self Test Responses, 4-39
Power-Up Self Test, 4-38
Privilege Modes, 3-17
Probe Common Ground Clip, 3-61
Probe Compensation Square Wave, 4-48
Probe Compensation, 4-46

- Probe Data Input, 3-47
- Probe External 16-bit Counter, 3-49
- Probe Fuse Blown Detection, 3-49
- Probe I/O Interface, 3-44
- Probe I/O Module Interface Addressing, 3-46
- Probe I/O Module Interface PCA, Removal, 4-16
- Probe I/O Module Interface, 3-42
- Probe I/O PCA, 7-17
- Probe Interface, 3-46
- Probe Light Drive and Control, 3-49
- Probe Offset Correction, 4-46
- Probe Operation Voltages, 3-49
- Probe Response Timing, 3-61
- Probe Self Test, 4-38
- Probe Speed Specifications, 3-60
- Probe Threshold Voltage Calculation, 3-47
- Probe Tip Input, 3-59
- Probe, 3-59, 7-12
- Probe/Pulser, 3-8, 3-59
- Programmer Keyboard, Access, 4-17
- Programmer's Keyboard, 3-9, 3-67
- Pulser Pulse Width, 3-62
- Pulser, 3-61
- Push Button Switch, 3-62

- RAM Configuration (U83), 3-25, 4-68
- RAM Configuration, 3-24
- RAM Parity, 3-26
- RAM Refresh, 3-25
- RAM Timing, 3-25
- ROM Select Logic, 3-26
- ROM, 3-26
- Read Cycle, 3-14
- Read-Modify-Write Cycle, 3-14
- Rear Panel Features, 2-5
- Removal, Disk Drive Assemblies, 4-14
- Removal, Hard Disk Controller, 4-14
- Removal, I/O Connector Interface PCA, 4-16
- Removal, MFI and Video Controller PCA, 4-16
- Removal, Main PCA, 4-16
- Removal, Power Supply, 4-14
- Removal, Probe I/O Module Interface PCA, 4-16
- Repair Techniques, 4-60
- Repair, Clip and Flying Lead Modules, 4-71
- Repair, Clock Module, 4-67
- Repair, Components, 4-54
- Repair, Display and Keypad, 4-66
- Repair, Floppy Disk Drive, 4-69
- Repair, General, 4-54, 4-66
- Repair, Hard Disk and Controller, 4-69
- Repair, I/O Connector, 4-67
- Repair, I/O Module, 4-71
- Repair, Main PCA, 4-66

Index

Repair, Monochrome Monitor, 4-71
Repair, Multi-Function Interface, 4-70
Repair, Power Supply, 4-68
Repair, Probe I/O, 4-67
Repair, RAM Modules, 4-68
Repair, Single-Point Probe, 4-67
Repair, Video Controller, 4-70
Required Tools and Test Equipment, 2-8, 4-4
Reset Signal Description and Generation, 3-23
Ribbon Cable Connections, 3-43

SCSI, 3-64
SMT Rework Tools and Supplies, 4-65
SOIC Lead Index, 4-59
SOIC Soldering, 4-64
Screen Overlay, 4-18
Screen Overlay, Installation, 4-18
Screen Overlay, Recommended Use, 4-18
Screen Overlay, Removal, 4-18
Self Test Routines, 4-38
Self Test, Display, 4-42
Self Test, I/O Module, 4-42
Self Test, Pod, 4-41
Self Test, Power-Up , 4-38
Self Test, Probe, 4-38
Service Information, 2-7
Shipping Information, 2-7
Side Features, 2-4
Signal Descriptions, 3-10
Small Outline Integrated Circuit (SOIC), 4-55
Small Outline Transistor (SOT), 4-56
Software Calibration, 4-48
Software Calibration, I/O Module to External, 4-50
Software Calibration, I/O Module to Pod, 4-50
Software Calibration, Probe to External (Clock Module), 4-48
Software Calibration, Probe to Pod, 4-49
Specifications, 2-10
Static Awareness, 4-54
Status Register, 3-56
Stop Counter, 3-53
Surface Mount Footprint, 4-57
Surface Mount Repair, 4-54
Surface Mount Technology, 4-54
Switch Settings, Clip Configuration 4-72
Switch Settings, Flying Lead Module Configuration 4-72
Sync Pulse Isolation, 3-55
System Components, 9100A, 2-6
System Components, 9105A, 2-6
System Connections, 4-9

Test Equipment, 2-7
Theory of Operation, 3-5
Tools and Supplies, 4-64
Troubleshooting, 4-54
Typical Probe Pulser Amplitude, 3-61

U18 Truth Table, 3-77

VDRV Voltage Regulator Simplified Schematic, 3-54
VHI and VLO for TTL and CMOS Logic Levels, 3-80
Vacuum Fluorescent Display, 3-35, 3-37
Video Character Data Format, 3-66
Video Controller PCA, 7-10
Video Controller, 3-65
Video Display Address Mapping, 3-65
Video Output, 3-67
Video RAM, 3-65
Video, 3-64
Voltage Threshold Levels, 3-48

Write Cycle, 3-14

